

# TA8080K

## 1.0A MOTOR DRIVER WITH BRAKE FUNCTION

The TA8080K is a 1.0A motor driver which directly drives a bidirectional DC motor. Inputs DI1 and DI2 are combined to select one of forward, reverse, stop, and brake modes. Since the inputs are TTL-compatible, this IC can be controlled directly from a CPU or other control system. The IC also has various protective functions.

### FEATURES

- Bidirectional DC motor driver.
- 1.0A current capacity.
- Four operation modes : Forward, reverse, stop, and brake.
- Recommended operating supply voltage range:  $V_{CC} = 6V$  to  $16V$
- Protective functions : Thermal-shutdown, short-circuit protection, and over-voltage shutdown.
- Built-in counter electromotive force absorption diodes.
- Plastic package HSIP-7pin.

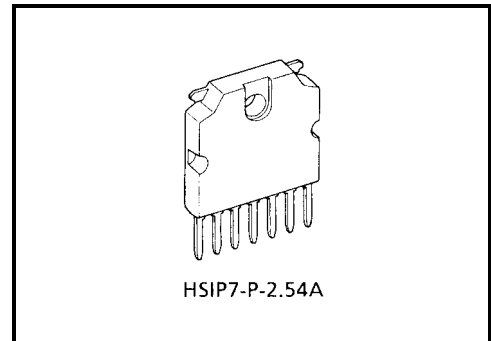

Weight: 2.2 g (typ.)

### BLOCK DIAGRAM AND PIN LAYOUT

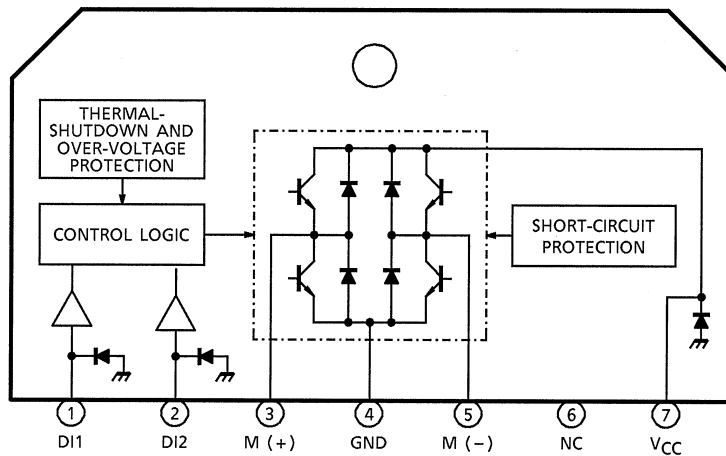

## PIN DESCRIPTION

PIN No.	SYMBOL	DESCRIPTION
1	DI1	Output status control pin. Connects to a PNP-type voltage comparator.
2	DI2	
3	M (+)	Connects to the DC motor. Both the sink and the source have a current capacity of 1.0A. Diodes for absorbing counter electromotive force are contained on the V <sub>CC</sub> and GND sides.
4	GND	Grounded
5	M (-)	Connects to the DC motor together with pin 3 and has the same function as pin 3. This pin is controlled by the inputs from pins 1 and 2.
6	NC	Not connected. (Electrically, this pin is completely open.)
7	V <sub>CC</sub>	Power supply pin. This pin has a function to turn off the output when the applied voltage exceeds 30.0 V, thus protecting the IC and the load.

## TRUTH TABLE

Input		Output		
DI1	DI2	M (+)	M (-)	
H	H	L	L	(Note)
L	H	L	H	
H	L	H	L	
L	L	OFF (high impedance)		(Note)

Note: Brake mode comes into effect when both M (+) and M (-) go low, Stop mode comes into effect when both M (+) and M (-) turn OFF.

## MULTI PROTECTIVE FUNCTIONS

The TA8080K contains three protective functions: Overvoltage (VSD), Overcurrent (ISD), and Overheat (TSD). All these functions are incorporated to protect the IC (even including the motor load) against degradation and breakdown due to power-derived overstresses. These three functions operate independently of each other. The following explains each function.

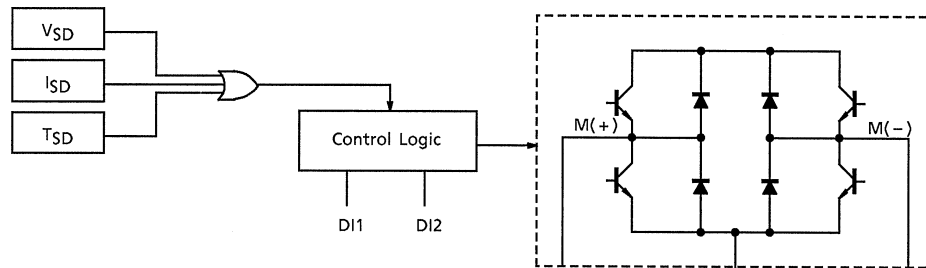

### 1. Overvoltage Protection (VSD)

- Basic Operation

When the voltage applied to the VCC pin is below the VSD detection level, output is controlled by input signals. However, when the VCC voltage exceeds the detection level, output goes to a high-impedance state irrespective of the input signal.

- Functional Description

The VSD voltage detection is accomplished by comparing the Zener and the VCC voltages. When the VCC voltage is higher than the Zener voltage, an instruction is forwarded to the control logic unit to turn off the output transistors. When it is lower than the Zener voltage, the logic unit is controlled by input signals, DI1 and DI2.

### 2. Overheat Protection (TSD)

- Basic Operation

When the junction temperature (chip temperature) is below the TSD detection level, output is controlled by input signals. However, when the junction temperature exceeds the detection level, output goes to a high-impedance state irrespective of the input signal.

- Functional Description

The temperature detection is accomplished by monitoring VF of the on-chip diode. The diode VF is compared with the internal reference voltage and if it is found below the reference voltage, an instruction is forwarded to the control logic unit to turn off the output transistors. When it is higher than the reference voltage, the logic unit is controlled by input signals, DI1 and DI2.

### 3. Overcurrent Protection (ISD)

- Basic Operation

When the output current ( $I_{\text{sink}}$  or  $I_{\text{source}}$  on pin 3 or pin 5) is below the ISD detection level, output is controlled by input signals. However, when the output current exceeds the detection level, output changes to a switching waveform like the one shown in Figure 1 below.

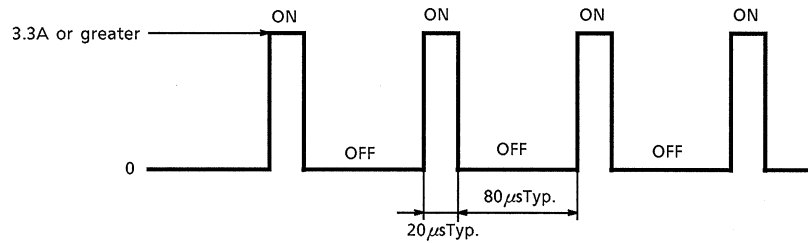

**Figure1. Basic Operation**

- Functional Description

The output current detection is accomplished by monitoring VBE of each output transistor. The detection sensor is connected to each output transistor, as well as to the short-circuiting protection circuit. If a current greater than the ISD detection level flows in any one of the four output transistors, the short-circuiting protection circuit is actuated.

This circuit contains a timer, so that when the overcurrent condition continues for  $20 \mu\text{s}$  (typ.), output is placed in the high-impedance state (output OFF). Then,  $80 \mu\text{s}$  (typ.) later, output is returned to output-ON mode. If the overcurrent condition still exists at this time, the above switching mode is repeated until the overcurrent condition is removed.

## MAXIMUM RATINGS (Ta = 25°C)

CHARACTERISTIC	SYMBOL	RATING	UNIT
Power Supply Voltage	V <sub>CC</sub>	30	V
	V <sub>CC</sub>	60 (1s)	
Input Voltage	V <sub>IN</sub>	-0.3~V <sub>CC</sub>	V
Output Current	I <sub>O-AVE</sub>	1.0	A
Power Dissipation	P <sub>D</sub>	12.5	W
Operation Temperature	T <sub>opr</sub>	-40~110	°C
Storage Temperature	T <sub>stg</sub>	-55~150	°C
Lead Temperature Time	T <sub>sol</sub>	260 (10s)	°C

## ELECTRICAL CHARACTERISTICS (V<sub>CC</sub> = 6~16V, T<sub>c</sub> = -40~110°C)

CHARACTERISTIC	SYMBOL	PIN	TEST CIRCUIT	TEST CONDITION	MIN	TYP.	MAX	UNIT
Power Supply Current	I <sub>CC1</sub>	V <sub>CC</sub>	—	Stop	—	8	15	mA
	I <sub>CC2</sub>		—	Forward / Reverse	—	20	40	
	I <sub>CC3</sub>		—	Brake	—	12	25	
Input Voltage	V <sub>IL</sub>	DI1 / DI2	—		—	—	0.8	V
	V <sub>IH</sub>		—		2.0	—	—	
Input Current	I <sub>IL</sub>	DI1 / DI2	—	V <sub>IN</sub> = 0.4V	-100	—	10	μA
	I <sub>IH</sub>		—	V <sub>IN</sub> = V <sub>CC</sub>	-10	—	10	
Output Saturation Voltage	V <sub>sat</sub> (total)	M (+) / M (-)	—	I <sub>O</sub> = 1.0A, T <sub>c</sub> = 25°C	—	2.0	2.5	V
			—	I <sub>O</sub> = 1.0A, T <sub>c</sub> = 110°C	—	2.0	2.5	
Output Leakage Current	I <sub>LEAK-U</sub>	M (+) / M (-)	—	V <sub>OUT</sub> = 0V	—	—	-10	μA
	I <sub>LEAK-L</sub>		—	V <sub>OUT</sub> = V <sub>CC</sub>	—	—	10	
Diode Forward Voltage	V <sub>F-U</sub>	M (+) / M (-)	—	I <sub>F</sub> = 1.0A	—	2.0	—	V
	V <sub>F-L</sub>				—	1.2	—	
Over-current Detection	I <sub>SD</sub>		—		1.2	1.7	2.3	A
Shutdown Temperature	T <sub>SD</sub>		—		—	150	—	°C
Over-voltage Detection	V <sub>SD</sub>		—		27	30	33	V
Thermal Resistance	R <sub>θj-c</sub>		—		—	4	—	°C / W
Transfer Delay Time	t <sub>pLH</sub>		—		—	1	10	μs
	t <sub>pHL</sub>		—		—	1	10	

Note: The parameter values above are guaranteed in the operating voltage range of 6V to 16V. If the guaranteed range is exceeded in practical use, make sure that the IC operates normally in application.

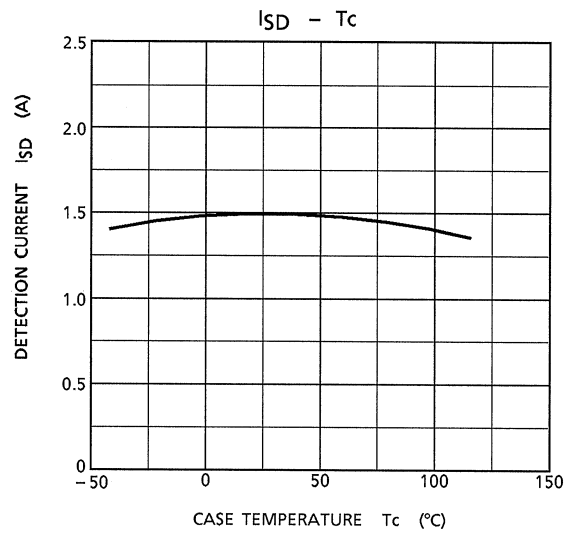
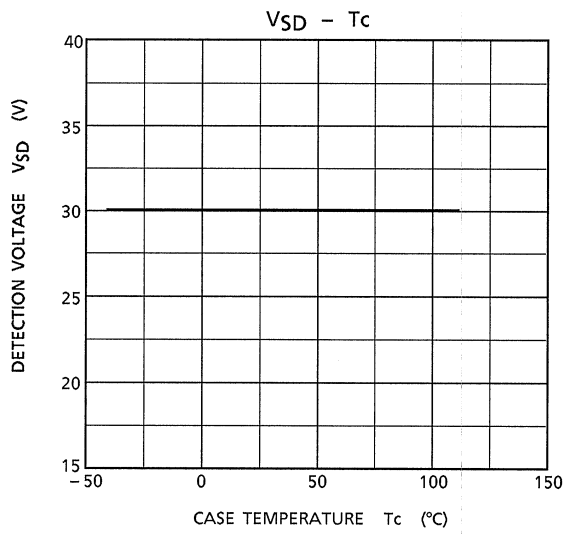
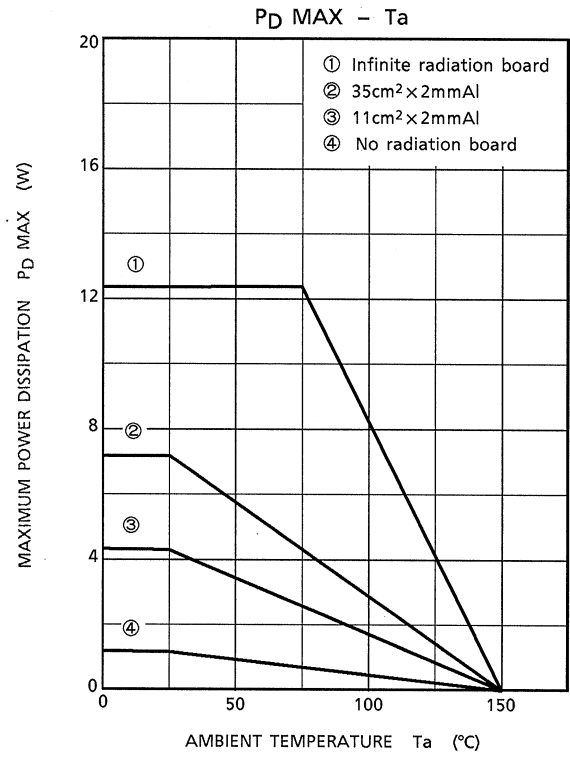
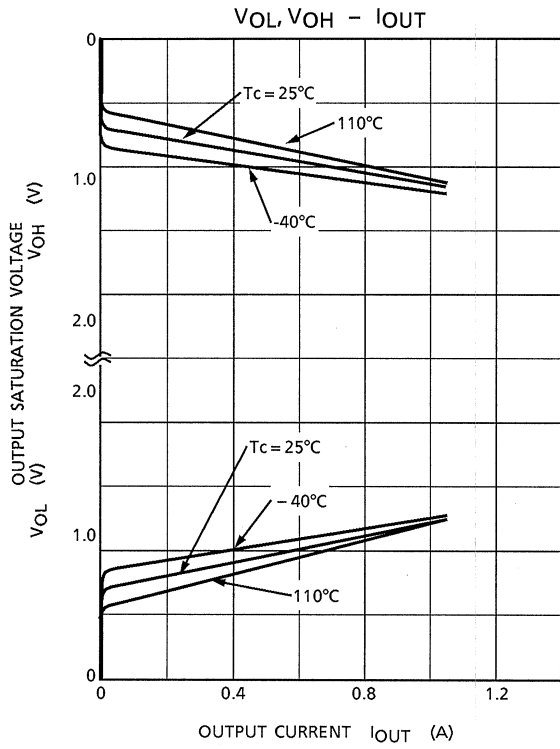

I/O EQUIVALENT CIRCUIT

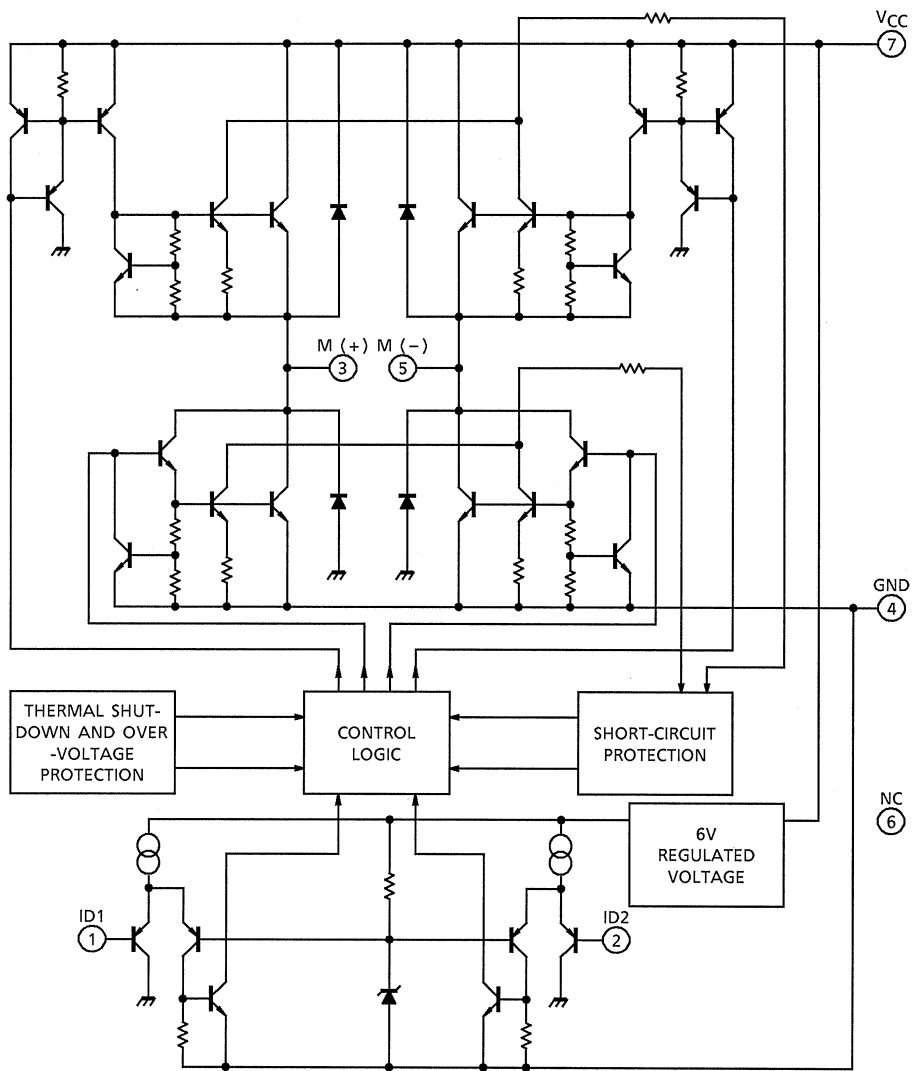

## EXAMPLE OF APPLICATION CIRCUIT

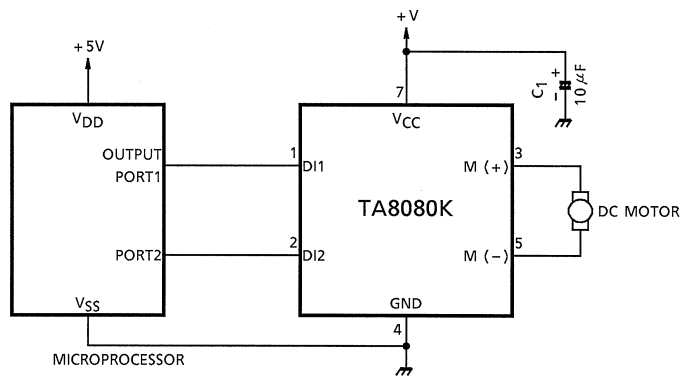

Cautions for Wiring : C<sub>1</sub> is for absorbing disturbance, noise etc.  
Connect it as close to the IC as possible.



## PACKAGE DIMENSIONS

HSIP7-P-2.54A

Unit : mm

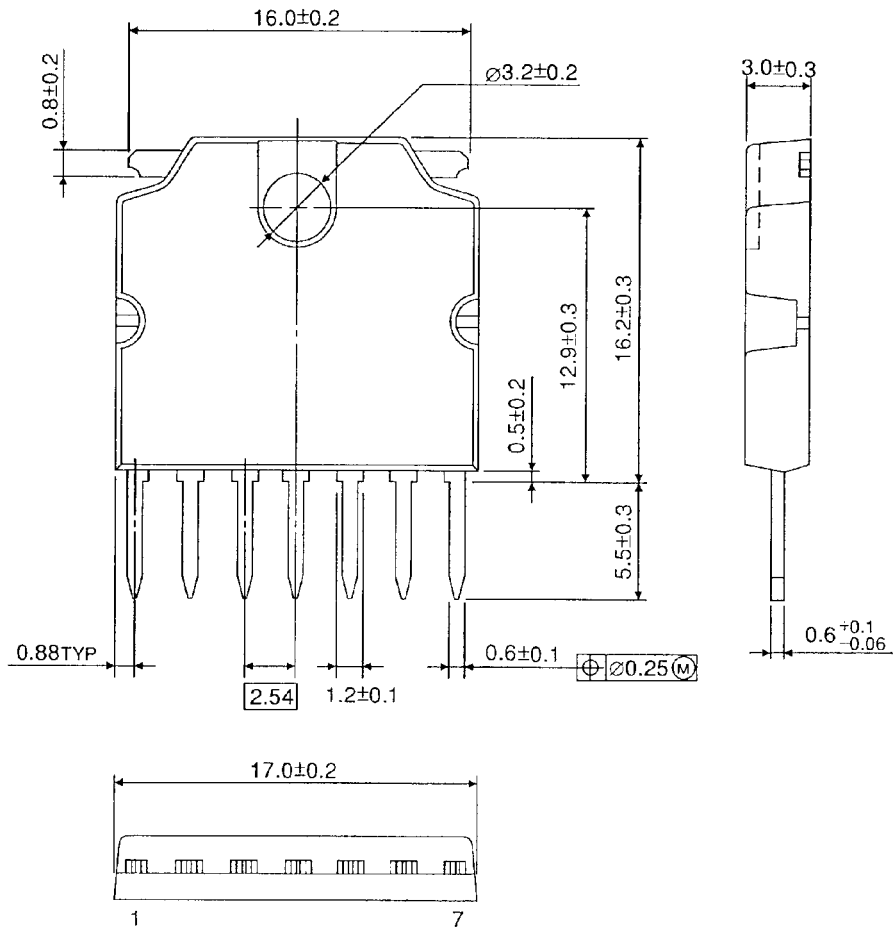

Weight: 2.2 g (Typ.)

**RESTRICTIONS ON PRODUCT USE**

000707EAA\_S

- TOSHIBA is continually working to improve the quality and reliability of its products. Nevertheless, semiconductor devices in general can malfunction or fail due to their inherent electrical sensitivity and vulnerability to physical stress. It is the responsibility of the buyer, when utilizing TOSHIBA products, to comply with the standards of safety in making a safe design for the entire system, and to avoid situations in which a malfunction or failure of such TOSHIBA products could cause loss of human life, bodily injury or damage to property.  
In developing your designs, please ensure that TOSHIBA products are used within specified operating ranges as set forth in the most recent TOSHIBA products specifications. Also, please keep in mind the precautions and conditions set forth in the "Handling Guide for Semiconductor Devices," or "TOSHIBA Semiconductor Reliability Handbook" etc..
- The information contained herein is presented only as a guide for the applications of our products. No responsibility is assumed by TOSHIBA CORPORATION for any infringements of intellectual property or other rights of the third parties which may result from its use. No license is granted by implication or otherwise under any intellectual property or other rights of TOSHIBA CORPORATION or others.
- The information contained herein is subject to change without notice.