

APPLICATION NOTE

Three-quadrant triacs bring major benefits to OEMs

We take for granted the electrical appliances and tools we use every day. We expect them to perform reliably, making our lives easier or more convenient. But what makes these appliances reliable and easy-to-use is electronic power control. At the heart of many modern appliances, the control device of choice is the simple, reliable and inexpensive triac. And for those appliances using motors or inductive/capacitive loads, **three-quadrant (3Q) triacs** bring major benefits to equipment manufacturers and end users in terms of design savings and performance. This article explains the advantages of 3Q triacs over traditional four-quadrant types.

Triggering quadrants explained

A 3Q triac (also known as a Hi-Com triac) can be triggered in three modes or 'quadrants,' whereas a 4Q triac can be triggered in all four modes. The principles and nomenclature are explained below.

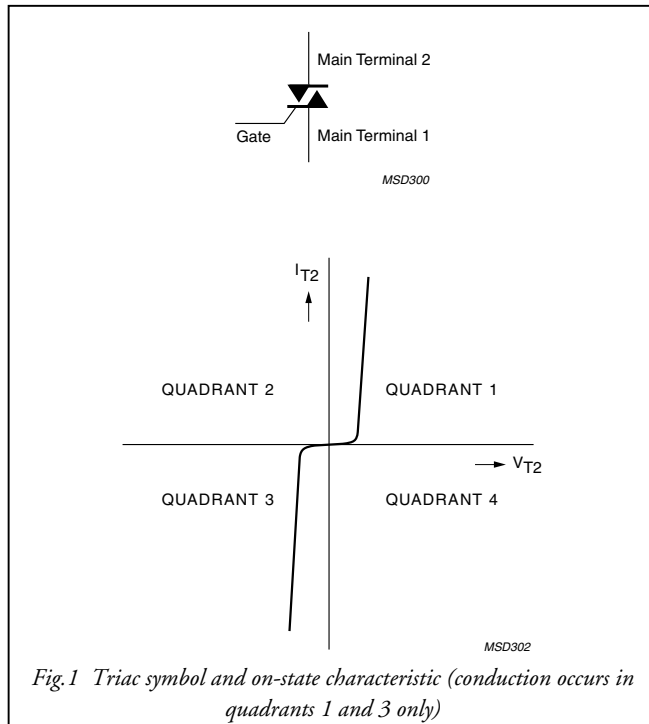

Fig. 1 Triac symbol and on-state characteristic (conduction occurs in quadrants 1 and 3 only)

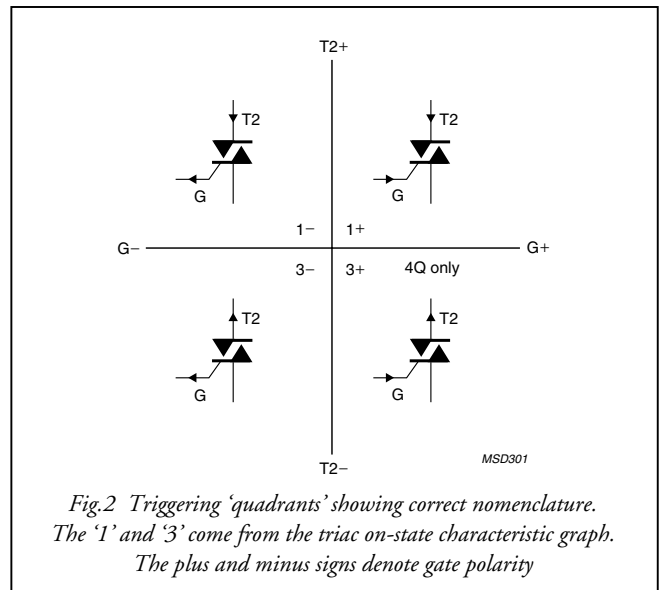

Fig. 2 Triggering 'quadrants' showing correct nomenclature. The '1' and '3' come from the triac on-state characteristic graph. The plus and minus signs denote gate polarity

The triggering quadrants are sometimes written longhand, e.g. (T2+, G-), and sometimes referred to as quadrants 1 to 4. The latter notation can lead to confusion with the triac on-state characteristic graph. Table 1 summarizes the different nomenclatures.

TABLE 1

Triac triggering quadrants — common nomenclature

Longhand	T2+, G+	T2+, G-	T2-, G-	T2-, G+
Shorthand	1+	1-	3-	3+
Common shorthand alternatives	I	II	III	IV

Why use three-quadrant triacs?

To prevent false/spurious triggering of triacs — causing uncontrolled triac conduction, and noisy and jerky motor operation — reliable circuits using 4Q triacs have always included additional protection components. Typically, an RC snubber across the triac's main terminals is used to limit the rate of change of voltage (dV/dt) and, in some cases, a large

inductor is needed to limit the rate of change of current at commutation (dI_{COM}/dt). These components add to circuit cost and size. Moreover, they can even reduce long-term reliability. Badly chosen snubber components can cause a damaging peak current and rate-of-rise of the current. This can happen if the triac is triggered when blocking a high voltage and the snubber capacitor discharges too rapidly through the triac.

The snubber consists of a mains-rated capacitor and a mains-rated carbon composition resistor connected in series. Typical component values are $0.1 \mu F$ and $\geq 100 \Omega$. A carbon composition resistor is required to handle the repetitive surge currents without burning out. The snubber components are chosen to limit the dV_{COM}/dt or dV_D/dt to a level that is guaranteed not to trigger the triac. The highest value of R and the lowest value of C which limit the dV/dt to the required level should be used to minimize the possibility of damaging discharge currents from the snubber capacitor.

4Q triacs have been available for many years but old habits die hard, so we continue to see their widespread use along with their extra protection components. Triacs could be considered as a mature technology. Despite this, things have not stood still in the triac world, and new developments continue:

- the comparatively recent arrival of 3Q 'Hi-Com' triacs means protection components are not generally needed, allowing more reliable, cheaper and smaller appliances
- 3Q triacs are available in high-quality surface-mount packages ranging from SOT223 and SOT428 (Philips' version of DPAK) to SOT404 (Philips' version of D³PAK). These further enable size and cost reductions for high-volume OEMs using surface mounting.

Application examples

Many small appliances require some form of power control, and most use triacs to switch or vary the power to the load. Heating or cooking devices use simple ON/OFF switching to maintain a temperature close to a set point. Likewise, compressors are switched on and off to control cooling in air conditioners, chillers and refrigerators.

For more advanced control, continuously or discretely variable power is required. Common examples are kitchen appliances: food processors, mixers, hand-blenders, etc., which require adjustable motor speeds to suit different tasks. Sewing machines are another very good example. A sewing machine that only runs at full speed would be of little use! And different applications are popular in different countries; for example:

- portable cooling fans with variable speed in the Far East
- cylinder vacuum cleaners with variable motor speed (to control suction while saving energy) in Japan and Europe
- front-loading washing machines with variable motor speed (for reverse action tumble washing and fast spin-drying) across Europe
- small kitchen appliances with speed-controlled motors all over the world.

Large 'white goods' such as washing machines and dish-washers, with advanced energy-saving features, use up to 8

triacs to control their motors, pumps and valves. Triacs provide the lowest cost and simplest route to reliable, interference-free switching and power control.

In most of these applications, a *phase-control* circuit is used to vary the power to brush motors. Figure 3 is a practical example: a motor-speed controller for a 1.5 kW vacuum cleaner. This illustrates just how simple a power controller can be using a triac. The 3Q triac makes it unnecessary to include snubber components for reliable operation.

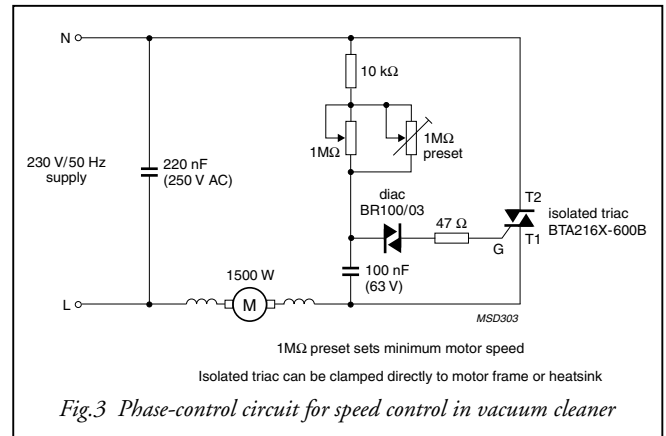

Fig.3 Phase-control circuit for speed control in vacuum cleaner

What happens inside a 4Q triac?

A 4Q triac is able to trigger in its 3+ quadrant (T2-, G+) because of the semiconductor structure — it has small overlapping sections in the 'gate' region. When operating in 3+, the main terminal load current is initiated remotely through several intermediate stages of conduction from one half of the triac die to the other. Because of this remote triggering method, 3+ operation has several disadvantages:

- the triac is the least sensitive (I_{GT} is the highest of all the four quadrants), so a higher gate current is needed to guarantee triggering
- the delay between applying gate current and the triac turning on is the longest of all four quadrants, so the gate current must be applied longer to guarantee triggering
- the permitted rate-of-rise of load current is the lowest of all four quadrants (lowest dI_T/dt). This means it's easier to cause localized hotspots and burn out the triac in the gate area when controlling loads with high inrush currents, such as capacitive loads and cold incandescent lamp filaments.

The triac's internal construction that enables it to trigger in the 3+ quadrant also allows mobile charge carriers to cross from one half of the triac to the other under conditions of high dI_{COM}/dt and high dV_{COM}/dt . This can result in an inability to turn off at the zero crossing of the load current.

Introducing three-quadrant triacs

A 3Q triac has a different internal construction to 4Q triacs with no critical overlapping structure at the gate. Though this

makes it unable to operate in the 3+ quadrant, eliminating 3+ triggering avoids all the disadvantages that befall 4Q triacs. As most circuits operate in the 1+ and 3- quadrants (for phase control), or 1- and 3- (for single polarity triggering from an IC or other electronic drive circuit), the loss of 3+ operation is a very small price to pay for the advantages gained.

Benefits of 3Q triacs for the OEM

1. Higher dV_{COM}/dt capability — no snubber required

At the end of a half cycle of the mains supply, the load current will pass through zero. Here the triac will turn off and return to the blocking state until another gate pulse is applied. Turn-off at the current zero crossing is called 'commutation.'

Controlling inductive loads (e.g. a motor, transformer or solenoid), there is a phase shift between the voltage and current waveforms. The load current lags the supply voltage. So at zero current, the commutating triac could suddenly be required to block a high voltage of opposite polarity. The rate of rise of commutating voltage that results will be restricted in many 50/60 Hz applications to 20 V/ μ s (typically), by the triac as it returns to the blocking state, and by stray capacitances within the circuit. This dV_{COM}/dt can easily be sufficient to prevent a 4Q triac from commutating, causing spontaneous conduction from the beginning of the next half cycle with no gate signal applied.

Traditionally, spurious triggering by dV_{COM}/dt has been avoided by connecting snubber components across the main triac terminals. *Using a 3Q triac, the snubber can be eliminated in most cases.*

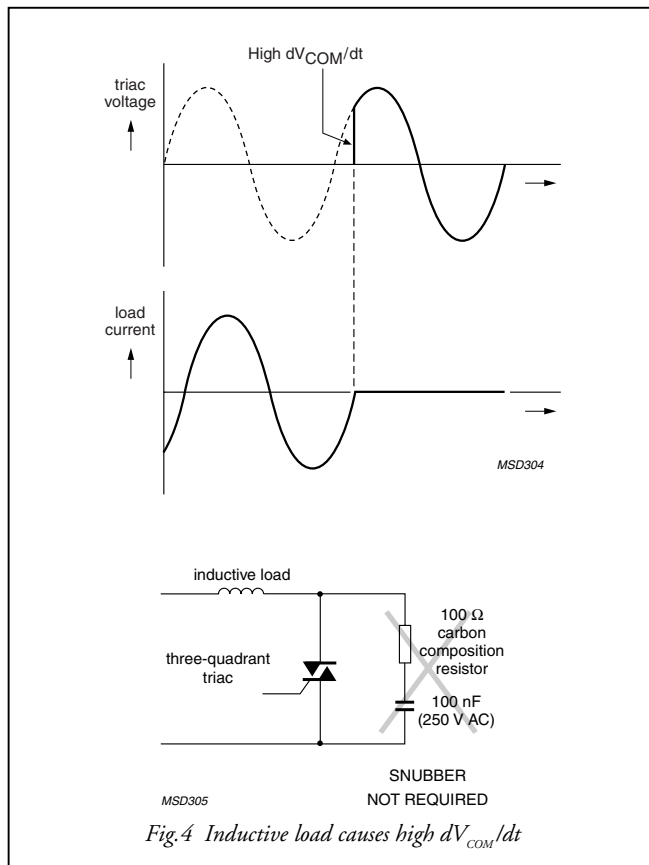

2. Higher dV_D/dt capability — no snubber required

If the circuit is exposed to mains transients and surges, for example when heavy inductive loads connected to the same circuit are switched on or off, or during a thunderstorm, it is possible that the triac will be exposed to a high rate of rise of off-state voltage (dV_D/dt). Coupling through the triac's internal junction capacitance can generate sufficient internal gate current to spontaneously trigger a 4Q triac. Again, the traditional way to avoid this has been to connect a snubber across its main terminals to limit the dV_D/dt to a level which is guaranteed not to trigger it. *Alternatively, if a three-quadrant triac is specified, the snubber can be eliminated in most cases.*

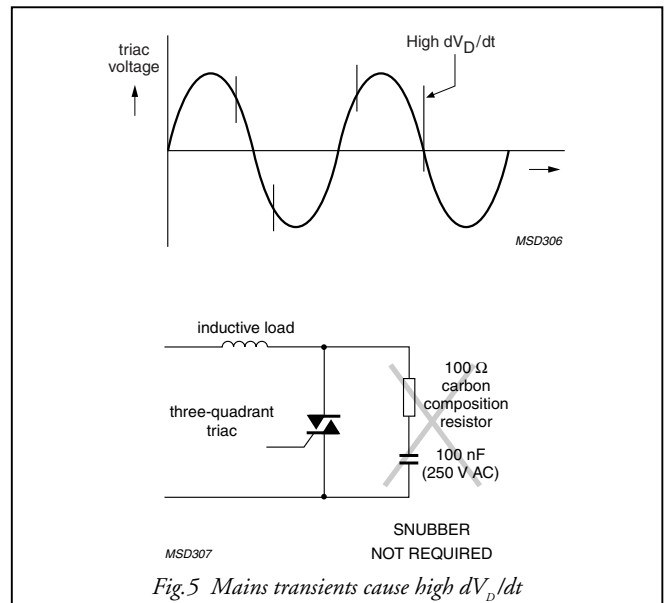

The removal of the triac's critical overlapping feature mentioned previously has given Philips' Hi-Com triacs a minimum dV_D/dt capability of 1000 V/ μ s and a typical capability of 4000 V/ μ s.

3. Higher dI_{COM}/dt capability — no series inductor required

Many applications require the triac to control a motor, or other inductive load, that is DC powered through a bridge rectifier. Examples of this are carbon brush or 'universal' motors which are run on rectified AC, and the small but powerful permanent magnet motors found in small kitchen appliances such as handheld bar blenders. These rectifier-fed motor loads impose very tough conditions on the triac.

During each half cycle of the mains, as the supply voltage reduces towards zero, a point will be reached when the back-emf generated by the motor is equal to the supply voltage. When the supply voltage continues to fall, the load current taken from the mains supply will stop abruptly and the motor current 'freewheels' around the bridge rectifier.

Current can only be taken from the supply via the triac when the supply voltage exceeds the motor's back-emf. When the supply voltage falls below the motor's generated voltage, the triac experiences a rapid fall in current as it approaches commutation. This high dI_{COM}/dt can be sufficient to prevent a

four quadrant triac from turning off *even if the dV_{COM}/dt is only $0.11 V/\mu s$* — this is the maximum rate of rise of a 240 V 50 Hz sine wave.

The traditional way to overcome this has been to limit the rate of change of current with a large series inductor of a few mH inductance. *Alternatively, a three-quadrant triac can successfully commute the high dI_{COM}/dt without the need for a series inductor.*

In laboratory testing of real applications, replacing a standard four-quadrant triac with an equivalent three-quadrant Hi-Com type made a big difference. 4Q triacs exhibited commutation failures at 40 °C whereas 3Q triacs successfully operated with mounting base temperatures of 150 °C — this was 25 °C above the recommended maximum junction temperature. This is especially impressive as all triacs become dramatically more sensitive at such high temperatures, making them more likely to suffer from spurious triggering. This was a tough and revealing test.

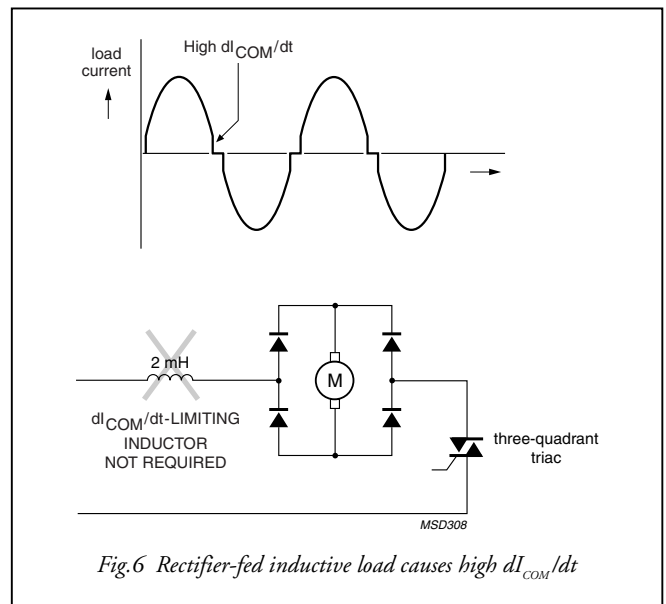

Philips Semiconductors – a worldwide company

Argentina: see South America
Australia: Tel. +61 2 9704 8141, Fax. +61 2 9704 8139
Austria: Tel. +43 1 60 101 1248, Fax. +43 1 60 101 1210
Belarus: Tel. +375 172 20 0733, Fax. +375 172 20 0773
Belgium: see The Netherlands
Brazil: see South America
Bulgaria: Tel. +359 2 68 9211, Fax. +359 2 68 9102
Canada: Tel. +1 800 234 7381, Fax. +1 800 943 0087
China/Hong Kong: Tel. +852 2319 7888, Fax. +852 2319 7700
Colombia: see South America
Czech Republic: see Austria
Denmark: Tel. +45 33 29 3333, Fax. +45 33 29 3905
Finland: Tel. +358 9 615 800, Fax. +358 9 6158 0920
France: Tel. +33 1 4099 6161, Fax. +33 1 4099 6427
Germany: Tel. +49 40 2353 60, Fax. +49 40 2353 6300
Hungary: see Austria
India: Tel. +91 22 493 8541, Fax. +91 22 493 0966
Indonesia: Tel. +62 21 794 0040 ext. 2501, Fax. +62 21 794 0080
Ireland: Tel. +353 1 7640 000, Fax. +353 1 7640 200
Israel: Tel. +972 3 645 0444, Fax. +972 3 649 1007
Italy: Tel. +39 039 203 6838, Fax. +39 039 203 6800
Japan: Tel. +81 3 3740 5130, Fax. +81 3 3740 5057
Korea: Tel. +82 2 709 1412, Fax. +82 2 709 1415
Malaysia: Tel. +60 3 750 5214, Fax. +60 3 757 4880
Mexico: Tel. +9-5 800 234 7381, Fax. +9-5 800 943 0087
Middle East: see Italy

Netherlands: Tel. +31 40 27 82785, Fax. +31 40 27 88399
New Zealand: Tel. +64 9 849 4160, Fax. +64 9 849 7811
Norway: Tel. +47 22 74 8000, Fax. +47 22 74 8341
Pakistan: see Singapore
Philippines: Tel. +63 2 816 6380, Fax. +63 2 817 3474
Poland: Tel. +48 22 5710 000, Fax. +48 22 5710 001
Portugal: see Spain
Romania: see Italy
Russia: Tel. +7 095 755 6918, Fax. +7 095 755 6919
Singapore: Tel. +65 350 2538, Fax. +65 251 6500
Slovakia: see Austria
Slovenia: see Italy
South Africa: Tel. +27 11 471 5401, Fax. +27 11 471 5398
South America: Tel. +55 11 821 2333, Fax. +55 11 821 2382
Spain: Tel. +34 93 301 6312, Fax. +34 93 301 4107
Sweden: Tel. +46 8 5985 2000, Fax. +46 8 5985 2745
Switzerland: Tel. +41 1 488 2741, Fax. +41 1 488 3263
Taiwan: Tel. +886 2 2134 2886, Fax. +886 2 2134 2874
Thailand: Tel. +66 2 745 4090, Fax. +66 2 398 0793
Turkey: Tel. +90 216 522 1500, Fax. +90 216 522 1813
Ukraine: Tel. +380 44 264 2776, Fax. +380 44 268 0461
United Kingdom: Tel. +44 208 730 5000, Fax. +44 208 754 8421
United States: Tel. +1 800 234 7381, Fax. +1 800 943 0087
Uruguay: see South America
Vietnam: see Singapore
Yugoslavia: Tel. +381 11 62 5344, Fax. +381 11 63 5777

For all other countries apply to: Philips Semiconductors, International Marketing & Sales Communications, Building BE-p, P.O. Box 218, 5600 MD EINDHOVEN, The Netherlands, Fax. +31 40 27 24825

Internet: <http://www.semiconductors.philips.com>

© Philips Electronics N.V. 1999

SCS 68

All rights are reserved. Reproduction in whole or in part is prohibited without the prior written consent of the copyright owner.

The information presented in this document does not form part of any quotation or contract, is believed to be accurate and reliable and may be changed without notice. No liability will be accepted by the publisher for any consequence of its use. Publication thereof does not convey nor imply any license under patent- or other industrial or intellectual property rights.

Printed in The Netherlands

Date of release: November 1999

Document order number: 9397 750 06518

Let's make things better.



PHILIPS