

State-of-charge indicator for NiMH and NiCd powered applications

SAA1500T

FEATURES

- 5-segment state-of-charge indication for LED or LCD displays
- Numerous display facilities to indicate the operational modes
- Designed for constant charge and varying discharge currents
- Large dynamic range of discharge currents
- Independent setting for charge and discharge efficiency
- Battery self-discharge compensation
- Automatic switch-over from fast to trickle charge (to prevent overcharging)
- Low standby current for permanent integration into a battery pack.

APPLICATIONS

- Intelligent battery powered, portable, applications with 'remaining energy' indication and fast charge control.

QUICK REFERENCE DATA

SYMBOL	PARAMETER	CONDITIONS	MIN.	TYP.	MAX.	UNIT
V_{CC}	supply voltage		1.8	–	7.0	V
I_{CC}	supply current	$V_{CC} = 2.6 \text{ V}; V_{CI} = 0 \text{ V}$	–	–	90	μA
f_{OSC}	fixed frequency	charging	–	4.2	–	kHz
V_{CI}	input sense voltage	discharging	20	–	200	mV
T_{amb}	operating ambient temperature		0	–	+70	$^{\circ}\text{C}$

ORDERING INFORMATION

EXTENDED TYPE NUMBER	PACKAGE			
	PINS	PIN POSITION	MATERIAL	CODE
SAA1500T	20	SO20L	plastic	SOT163AH

State-of-charge indicator for NiMH and NiCd powered applications

SAA1500T

INTRODUCTION

More and more portable appliances are being used because they can operate independently from power sources such as mains or car batteries (see Fig. 1). In many cases, NiCd (powerful appliances) and NiMH (environment) rechargeable batteries are used. Because of the constant voltage of these batteries, it is not the energy (Wh) but the charge amount (Ah) that has to be known to enable the state-of-charge indication. In systems with known charge and discharge currents, time is an equivalent for the charge amount in the battery ($t = Q/I$). The charge time can be registered easily on a counter.

The system can be made universal by adapting the counting frequency to the used battery type, thereby making the counter contents a reflection of the energy state of the battery. The requirements of a battery state-of-charge indicator are in many ways similar to those of a fuel gauge for a car.

The SAA1500T is designed for enhanced systems with varying discharge currents. A variety of loads can discharge the battery without disturbing the charge

account. If the equivalent of the charge counter contents is known in the SAA1500T, then the following information can be made available:

- The state-of-charge, indicated by LED or LCD displays
- The battery low state, indicated by LED and acoustic alarms
- The full state. A control signal can automatically switch the charge current from a fast to a trickle level to prevent overcharge.

The state-of-charge indication is an important and useful addition to any rechargeable battery pack for a variety of reasons. An underlying problem is the common tendency to recharge batteries many times, in fact more often than actually necessary. People waste time and effort in this way because they are always afraid of being caught out with flat batteries. The state-of-charge indicator helps to overcome this problem and brings other benefits such as:

- Increased battery cycling and consequently improved battery performance and lifetime
- Enhanced customer satisfaction
- Excellent selling feature.

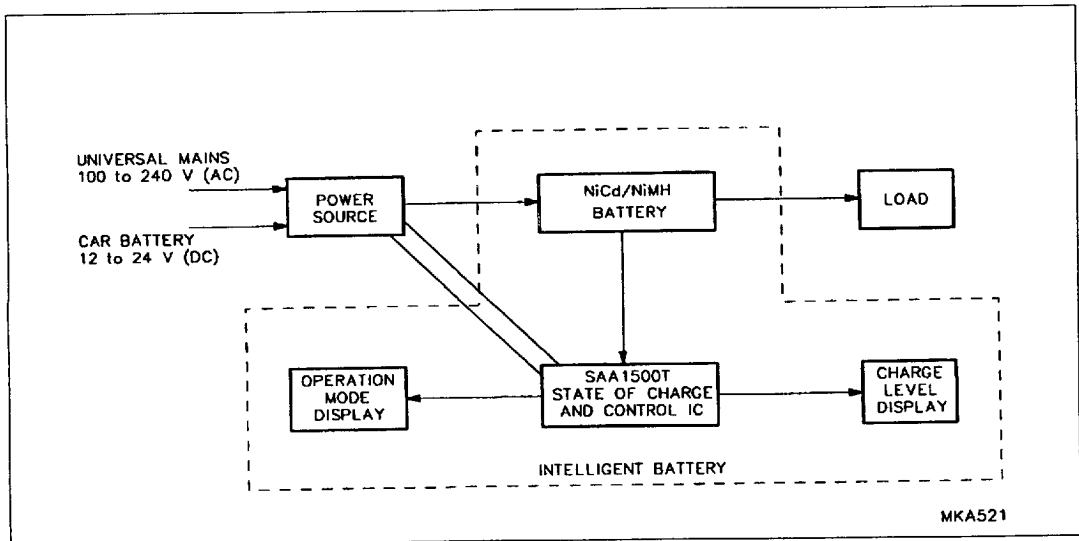

State-of-charge indicator for NiMH and NiCd powered applications

SAA1500T

GENERAL DESCRIPTION

The SAA1500T is manufactured in a low voltage SACMOS process and has been designed for use as a battery state-of-charge indicator and as a battery charge controller for rechargeable batteries. In principle only four states exist (but because of two charging levels, fast and trickle charge), six states can be considered for the batteries; fast and trickle charge, fast and trickle charge and discharge at the same time, standby and battery discharge (see Fig.2 State diagram).

During charging, activated by power-on, the charge rate increases linearly with the charge time (assuming constant charge current). During discharge, activated by the 'load switch ON', the charge rate decreases linearly

with the discharge time and the discharge current level. During charge/discharge, the charge rate is kept constant. In standby, the charge rate is decreased to compensate for the battery self-discharge.

In the SAA1500T, the known charge current and the measured discharge current are transferred in up/down oscillator pulses. By book-keeping the pulses, an image of the battery charge is created in the counter. The contents of the counter are output via 5 LEDs or a 6 segment LCD bar graph display. Two signal outputs are available to drive the LEDs to indicate whether the batteries are being charged or to indicate the nearly empty state.

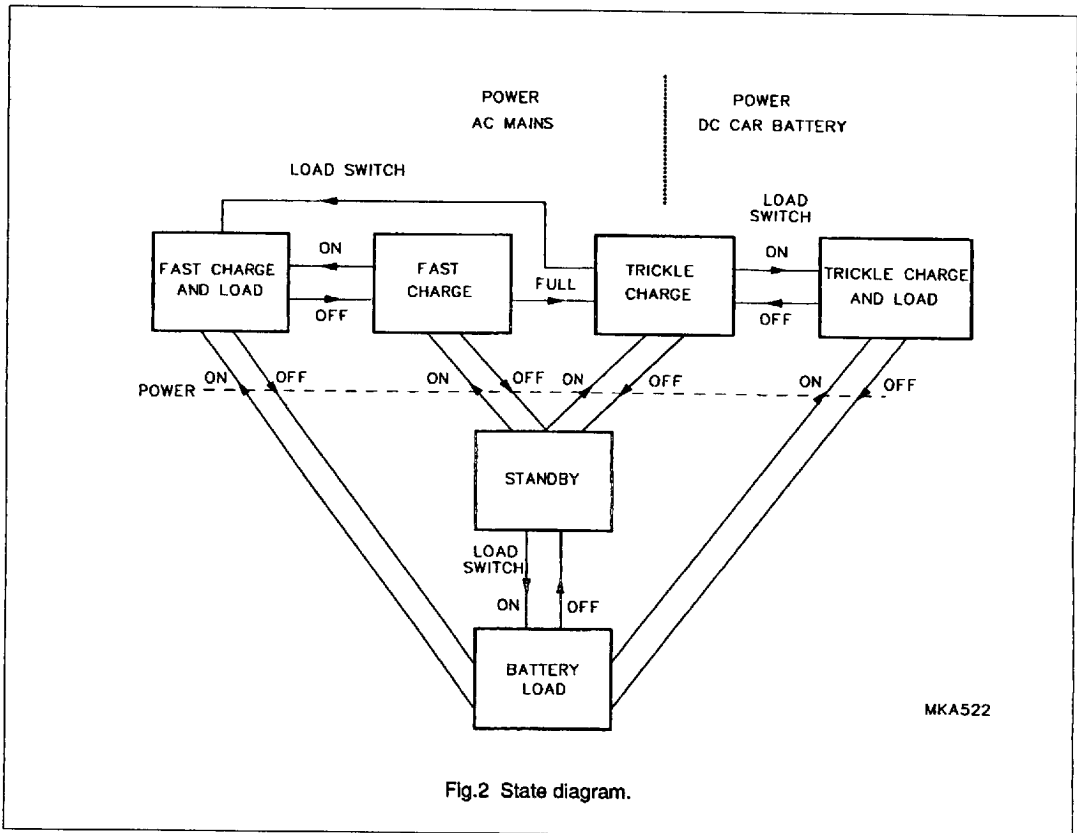

State-of-charge indicator for NiMH and NiCd powered applications

SAA1500T

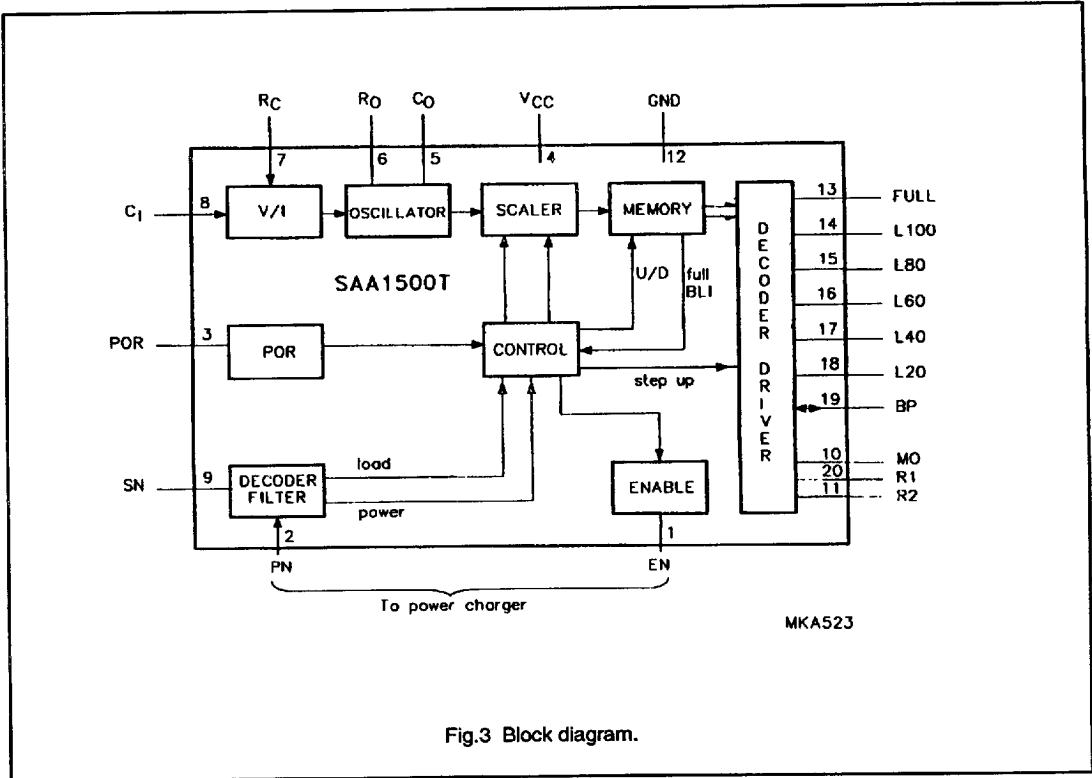

Fig.3 Block diagram.

State-of-charge indicator for NiMH and NiCd powered applications

SAA1500T

PINNING

SYMBOL	PIN	DESCRIPTION
EN	1	enable control signal for battery charge unit
PN	2	power NOT mode detection
POR	3	power-on-reset, reset at LOW battery voltage
V _{CC}	4	supply voltage
C _O	5	capacitor for oscillator frequency
R _O	6	resistor for charge or self-discharge oscillator frequency
R _C	7	resistor to convert sense input voltage
C _I	8	discharge current sense input
SN	9	switch NOT, load switch ON detection
MO	10	mains ON state indication
R2	11	battery LOW drive signal for external buzzer
GND	12	ground
FULL	13	battery FULL indication, only LCD
L100	14	100% indication, LCD or LED driven
L80	15	80% indication, LCD or LED driven
L60	16	60% indication, LCD or LED driven
L40	17	40% indication, LCD or LED driven
L20	18	20% indication, LCD or LED driven
BP	19	backplane, (LCD), LCD/LED mode detection input
R1	20	battery LOW indicator, LOW drive

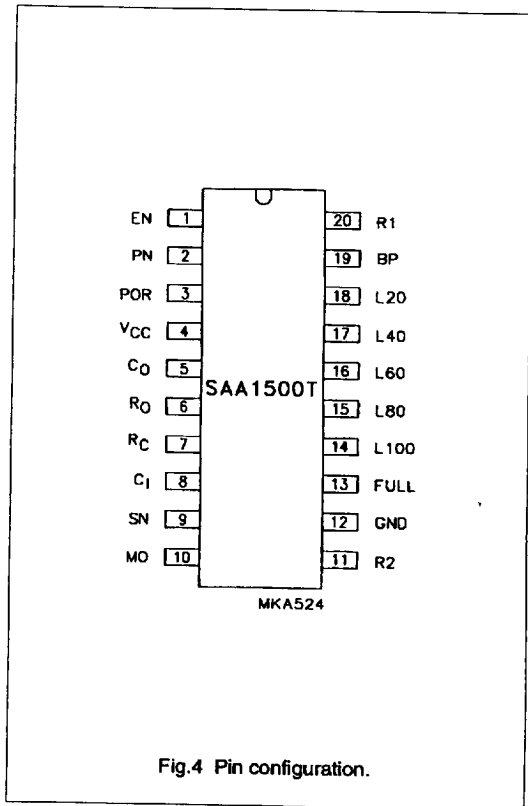

Fig.4 Pin configuration.

FUNCTIONAL DESCRIPTION

Power-on-reset

The POR circuit resets all counters if the supply voltage rises from 0 to V_{CC}. Reset is performed before V_{CC} = 1.8 V.

If the rise time of V_{CC} is fast, an external resistor and capacitor ensure the minimum pulse width of the internal reset pulse. If the rise time of V_{CC} is slow, the POR circuit acts as a level detector. The counters are also reset before V_{CC} = 1.8 V.

Oscillator (see Fig.5)

An RC type oscillator is used in the SAA1500T. The HIGH and LOW switching levels, and thus the voltage swing of the oscillator, are derived from V_{CC}. The timing components are designed so that the oscillator frequency is at V_{CC} and temperature independent.

The rise and fall times of the oscillator period are:

$$t_r = R_O \times C_O \times \ln 2; \quad t_f = R_C / 10 \text{ k}\Omega \times C_O \times \ln 2; \\ t_u = 15 \mu\text{s} \text{ (9.1)}$$

t_u is the undershoot time. The timings given in the specification are referenced to a fixed frequency of 4.2 kHz. Table 1 gives the modes at which the fixed frequency is active.

State-of-charge indicator for NiMH and NiCd powered applications

SAA1500T

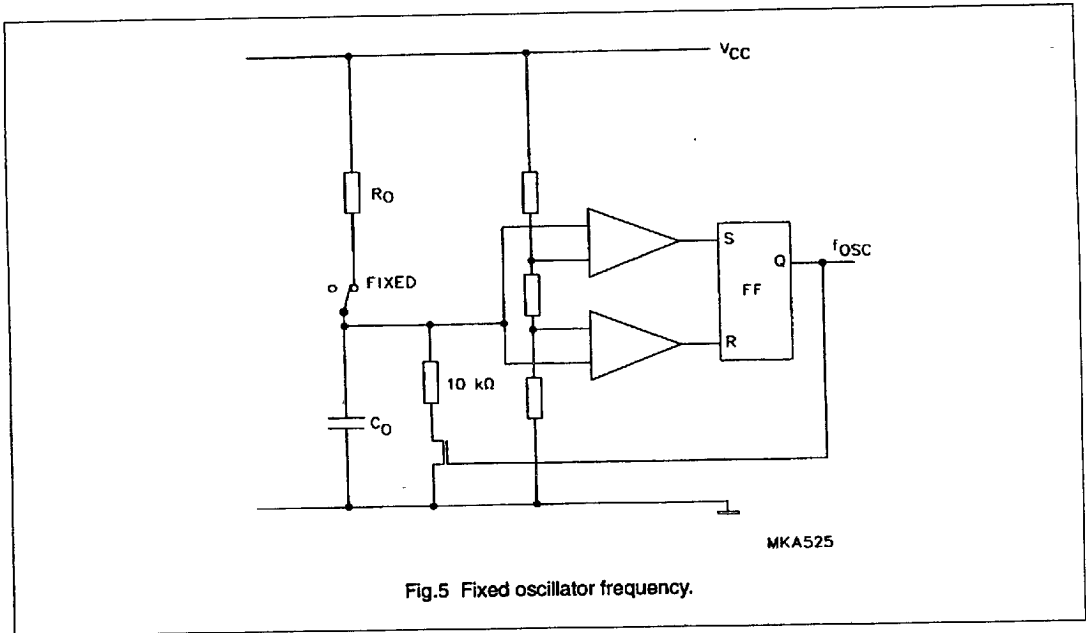

Fig.5 Fixed oscillator frequency.

V/I convertor (variable frequency)

The discharge current is sensed over a low ohmic (less dissipation) resistor R_{sense} (70 mΩ). In the voltage-to-current block (V/I), the sense voltage is converted into a current and this current is used to charge the oscillator capacitor C_O , (see Fig.6).

The period time can be calculated using the following equation:

$$t_r = (C_O \times V_{CC} \times R_{\text{conv}}) / (3 \times I_{\text{load}} \times R_{\text{sense}});$$

$$t_r \approx 10 \text{ k}\Omega \times C_O \times \ln 2; t_r \approx 15 \mu\text{s} \quad (9.2)$$

The rise time is the dominating factor, and so it is clear that the countdown frequency is proportional to the discharge current.

In the discharge mode the frequency is V_{CC} dependent. However, as the battery voltage is rather insensitive to the battery charge, this influence is low.

The input voltage to the V/I block ranges from 20 mV to 200 mV. Outside of this range it is less accurate (see Fig.7).

State-of-charge indicator for NiMH and NiCd powered applications

SAA1500T

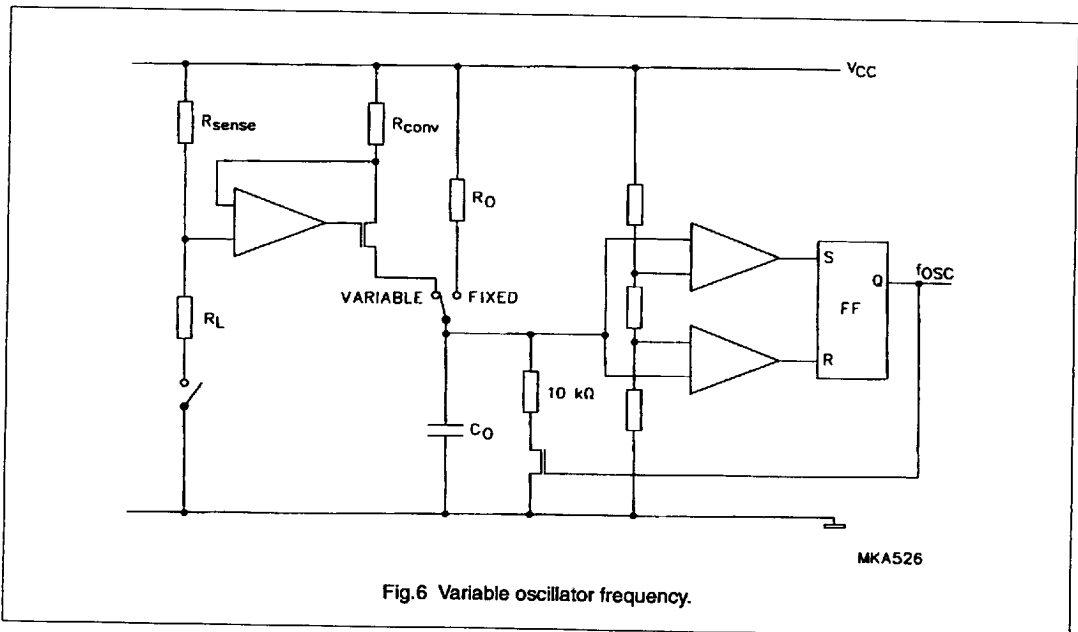

Fig.6 Variable oscillator frequency.

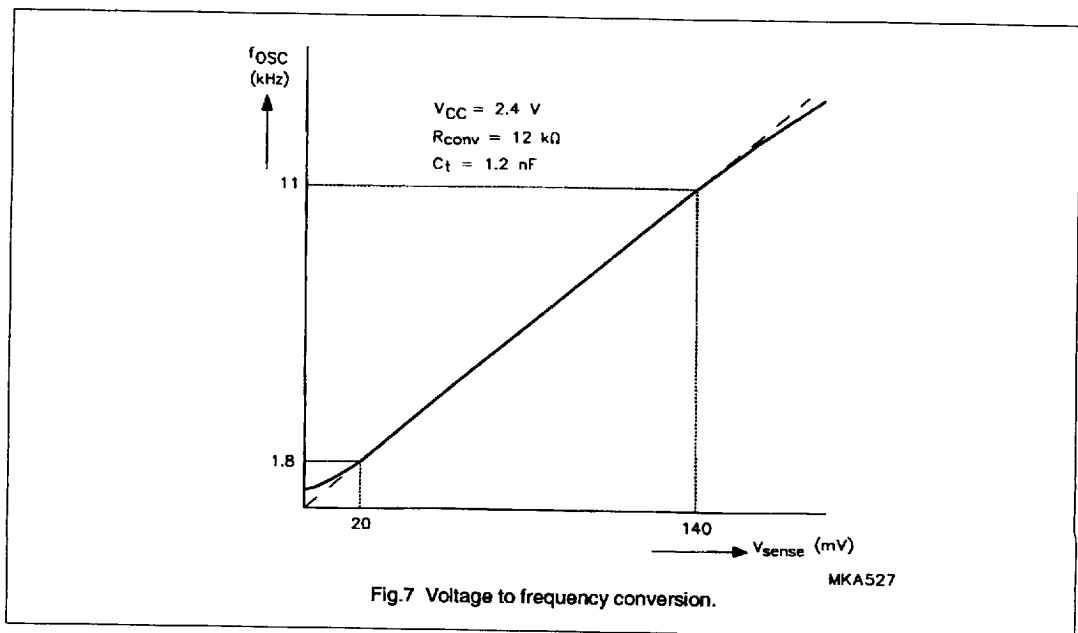

Fig.7 Voltage to frequency conversion.

State-of-charge indicator for NiMH and NiCd powered applications

SAA1500T

Decoder filter

In the decoder filter block, the two inputs PN (power NOT) and SN (switch NOT) are tested. SN is tested on two logic states (HIGH and LOW) and PN on four states (HIGH, LOW, >5Ffixed and <3Ffixed). The inputs are digitally filtered to make them insensitive to external interference caused by motor commutation currents. The PN input informs the SAA1500T about the power charge unit state. The most important states are; fast charge, trickle charge and no power.

The SN input informs the SAA1500 about the load state. Two states are possible, load or no load. The load switch is sensed for that information.

Memory

The memory has a fixed volume of ten times. The memory contents (= battery charge) will be output via the decoder/driver block.

Scaler

In the scaler, a scale factor is introduced to scale down the memory counting frequency. In the trickle and standby modes, the battery current is adapted and so the memory counting frequency is changed accordingly. For the following modes, fixed scale factors are programmed:

- fast charge = 7.37×10^5
- trickle charge = $32 \times$ fast charge
- standby = $150 \times$ trickle charge
- discharge mode = 8.85×10^5 .

Control

In the control block, in co-operation with the decoder/filter, six user modes and two test modes are provided together with appropriate signals to select the correct scale factors. The pin control signals, the different modes of operation, the oscillator frequency and scale factors are given in Table 1. The direction of the scale factor, up or down, is dependent on the mode, and thus determined in the control block. Four user modes have been explained previously.

In the 'trickle charge and load mode', the discharge current is nearly always much higher than the trickle charge level, consequently the scale factor is chosen to be the same as in the discharge mode.

In many cases a motor is driven in the 'fast charge and load mode'. The control pin EN switches the system from a current source to a voltage source regulation to keep the motor speed constant. This ensures that only the

current demanded by the motor will be delivered and the batteries will remain unaffected. For this reason a scale factor of zero is selected in this mode.

During the two test modes the scale factor is set at 1 to speed up the counter checks.

Step-up means that LEDs are switched on successively at the beginning of an LED display. If the LEDs are already active, there will be no step-up. Only those LEDs that are concerned with the charge status are activated. The step up frequency is $2 \times 10^{-3} \times f_{OSC}$ (see appendix B). The LED and LCD display, during charge and discharge, is illustrated in Fig.12 (Appendix A) and in Fig.13 (Appendix B).

The memory block passes information to the control unit concerning the extreme states of the battery charge. At batteries FULL, a signal is sent to the enable block to terminate the fast charge session. At batteries almost empty, a Battery Low Indication (BLI) signal is sent to the decoder/driver (see also appendix A).

State-of-charge indicator for NiMH and NiCd powered applications

SAA1500T

Table 1 Modes of operation.

INPUTS		MODES OF OPERATION	INDEX	OSCILLATOR FREQUENCY	SCALE FACTOR
PN	SN				
L	L	test, very fast down count	TD	fixed	512
<3Ffix	L	trickle charge and load, count down	TCL	variable	885k
>5Ffix	L	fast charge and load, no count	FCL	fixed	0
H	L	battery load, count down	BL	variable	885k
L	H	test, very fast up count	TU	fixed	512
<3Ffix	H	trickle charge, slow up count	TC	fixed	23M6
>5Ffix	H	fast charge, fast up count	FC	fixed	737k
H	H	standby, self discharge, POR active	SB	fixed	7G1
H	H	standby, self discharge, after POR	SB	fixed	3G5

Enable

It is possible to use the enable output (EN) to control the fast charge on the batteries. The EN signal is HIGH when the indicator shows not full. When an LED bar-graph is used and it shows FULL, then the EN signal

will pulsate between HIGH and OPEN states. This provides a pulsating trickle charge waveform with a 5% duty factor for a 10 second period to compensate for the LED currents. If an LCD bar-graph is used, then at the full state, the EN output goes into a continuous high impedance state (see Fig.8).

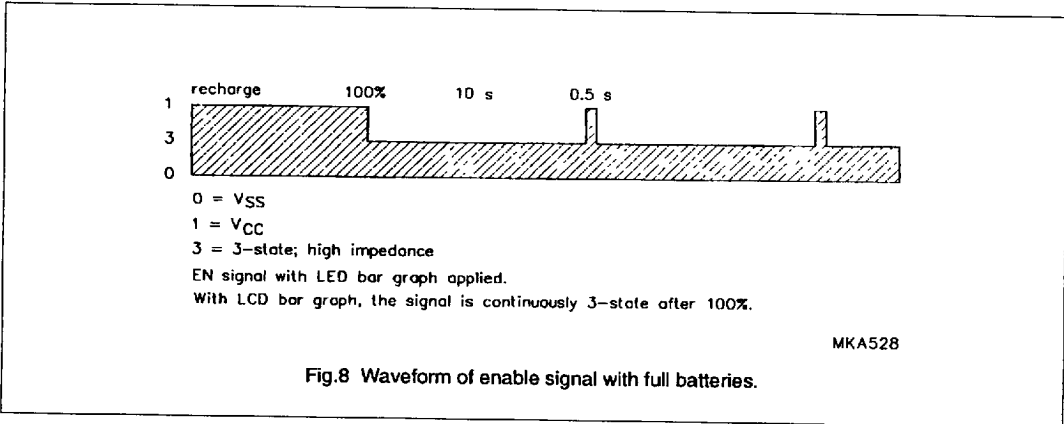

State-of-charge indicator for NiMH and NiCd powered applications

SAA1500T

Decoder driver

The SAA1500T is intended to display the charge of the batteries in a six segment LCD bar graph or five segment LED display. LED indication is also given for batteries nearly empty, batteries on recharge and batteries full during recharge. Outputs L100, L80, L60, L40, L20 and FULL are designed to drive an LCD bar-graph with output BP connected to the backplane of the LCD. The LCD segment is active if the segment voltage is in antiphase with the BP voltage. If, however, BP is

connected to ground (V_{SS}), then outputs L100, L80, L60, L40 and L20 may drive the LEDs directly with their anodes connected to the positive supply (V_{CC}). Outputs MO and R1 can drive LEDs directly. Output MO indicates batteries on recharge (LED constantly ON) and batteries full while recharging (LED flashes). Output R1 indicates that the battery is nearly empty. Output R2 provides a second battery nearly empty signal which can be used to drive a simple electroacoustic transducer with an audio tone via an external transistor. Circuit waveforms are illustrated in Fig.9.

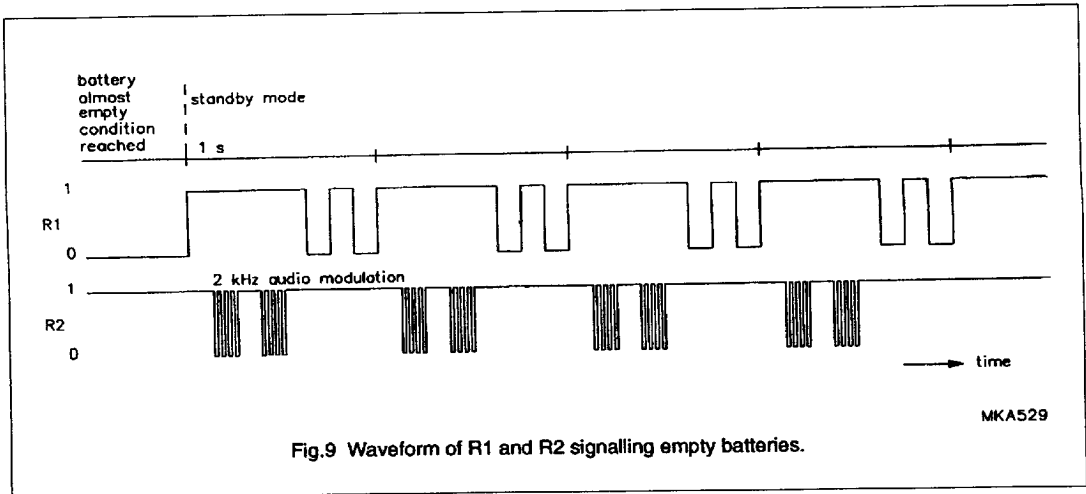

Fig.9 Waveform of R1 and R2 signalling empty batteries.

LIMITING VALUES

In accordance with the Absolute Maximum Rating System (IEC 134).

SYMBOL	PARAMETER	CONDITIONS	MIN.	MAX.	UNIT
V_{CC}	supply voltage		-0.5	7.0	V
V_i	input voltage	note 1	-0.5	$V_{CC}+0.5$	V
V_o	output voltage	note 1	-0.5	$V_{CC}+0.5$	V
I_{CC}	supply current		-	40	mA
I_{SS}	supply current		-	-120	mA
I_i	input current		-	± 10	mA
I_o	output current		-	± 20	mA
T_{amb}	operating ambient temperature		0	+70	$^{\circ}C$
T_{stg}	storage temperature		-65	+150	$^{\circ}C$

Note

- $V_{CC} + 0.5 V$ must not exceed 7.0 V.

State-of-charge indicator for NiMH and NiCd powered applications

SAA1500T

DC CHARACTERISTICS

T_{amb} - 25 °C; unless otherwise specified.

SYMBOL	PARAMETER	CONDITIONS	MIN.	TYP.	MAX.	UNIT
V _{OH}	HIGH level output voltage (pins 13 and 19)	V _{CC} = 2.4 V; I _O = -650 μA	2.0	-	-	V
V _{OH}	HIGH level output voltage (pins 1 and 11)	V _{CC} = 2.4 V; I _O = -1 mA	2.0	-	-	V
V _{OH}	HIGH level output voltage (pins 10, 14 to 18 and 20)	V _{CC} = 2.4 V; I _O = -300 μA	2.0	-	-	V
V _{OL}	LOW level output voltage (pins 13 and 19)	V _{CC} = 2.4 V; I _O = 650 μA	-	-	0.4	V
V _{OL}	LOW level output voltage (pin 11)	V _{CC} = 2.4 V; I _O = 1 mA	-	-	0.4	V
V _{OL}	LOW level output voltage (pins 10 14 to 18 and 20)	V _{CC} = 3.8 V; I _O = 15 mA	1.8	-	-	V
		V _{CC} = 2.4 V; I _O = 5 mA	-	-	0.55	V
I _{LO}	output leakage current (pins 1 and 19)	V _{CC} = 3.8 V; V _O = V _{CC} or 0 V	-	-	±1	μA
I _{L1}	input leakage current (pin 3)	V _{CC} = 3.8 V; V _S = 0 V	-	-	1	μA
I _{L1}	input leakage current (pin 2)	V _{CC} = 3.8 V	-	-	1	μA
I ₉	input current (pin 9)	V _{CC} = 2.4 V	30	-	80	μA
V _{th}	Schmitt trigger HIGH (pins 2, 9 and 19)	V _{CC} = 2 V	1.6	-	-	V
		V _{CC} = 4 V	2.2	-	-	V
V _{tl}	Schmitt trigger LOW (pins 2, 9 and 19)	V _{CC} = 2 V	-	-	0.4	V
		V _{CC} = 4 V	-	-	0.18	V
V _{hys}	hysteresis voltage (pins 2, 9 and 19)	V _{CC} = 2 V	0.4	-	-	V
		V _{CC} = 4 V	0.5	-	-	V
V _{HI}	HIGH level input voltage (pin 3)	V _{CC} = 3.8 V; I _S = 1 μA	0.8	-	1.5	V
		V _{CC} = 1.8 V; I _S = 1 μA	-	-	1.55	V
V _L	LOW level input voltage (pin 3)	V _{CC} = 1.8 V; I _S = 1 μA	-	-	1.55	V
I ₅	input current (pin 5)	V _{CC} = 2.4 V; V _S = 2.4 V	150	-	360	μA
I _{CC}	supply current	V _{CC} = 2.6 V; V _S = V _E = 0 V; V _S = V ₇ = 0 V	-	-	90	μA

State-of-charge indicator for NiMH and NiCd powered applications

SAA1500T

AC CHARACTERISTICS

$T_{amb} = 25\text{ }^{\circ}\text{C}$; unless otherwise specified.

SYMBOL	PARAMETER	CONDITIONS	MIN.	TYP.	MAX.	UNIT
f_{osc}	fixed oscillator frequency	$V_{CC} = 2.4\text{ V}$; $R_8 = 260\text{ k}\Omega$ $C_5 = 1.2\text{ nF}$; $V_8 = V_2 = V_9 = 0\text{ V}$	3.81	4.24	4.67	kHz
Δf_{osc}	variable oscillator frequency	$V_{CC} = 2.4\text{ V}$; $V_8 = 56\text{ mV}$; $R_7 = 12\text{ k}\Omega$ $C_5 = 1.2\text{ nF}$; $PN = 1$; $SN = 0$	4.04	4.65	5.02	kHz
		$V_{CC} = 2.4\text{ V}$; $V_8 = 35\text{ mV}$; $R_7 = 12\text{ k}\Omega$ $C_5 = 1.2\text{ nF}$; $PN = 1$; $SN = 0$	2.47	2.94	3.24	kHz
SVRR	supply voltage ripple rejection	$V_{CC} = 2.2\text{ to }2.6\text{ V}$; $V_8 = 49\text{ mV}$	-	-	5	%/0.1V

QUALITY SPECIFICATION

General quality specification for integrated circuits: UZW - BO/FQ - 601.

APPLICATION INFORMATION

The SAA1500T can be used in many applications with different types and sizes of rechargeable batteries. In the Introduction it is stated that the discharge/charge time is the equivalent of the battery charge.

The formula of the elapsed discharge/charge time and thus the collected charge is (see Fig.3):

discharge/charge time = t_{osc} x scale factor x memory

(1) The fixed time period of the oscillator during charging is given in the following equation:

$$t_{osc} = (\text{Charge Time}) / (\text{scale factor} \times 10)$$

Where: the Charge Time (CT) is the time taken to fully charge empty batteries.

Therefore: $f_{osc} = 7370 / (3600 \times CT [h])$ [kHz]; (exclusive efficiency corrections) (13.1)

From formula (13.1) it is clear that the fixed oscillator frequency is dependent on the charge time (and so the charge current) and not on the battery size.

If the charge time and the oscillator frequency are fixed, the external components C_0 and R_0 can be calculated with formula (9.1). Some examples are given in Table 2.

(2) Many timing functions are related to the fixed oscillator frequency. The most important are the trickle charge and the self-discharge times (see also Table 2).

(3) The variable time period of the oscillator during discharge is given in the following equation:

$$t_{osc} = (\text{discharge time}) / (\text{scale factor} \times 10)$$

Therefore: $f_{osc} = 8850 / (3600 \times DT)$ [kHz] (13.2)

Furthermore, formulas (9.1) and (9.2) are valid and, combining them with formula (13.2), the external components R_{conv} and R_{sense} can be calculated:

$$R_{conv}/R_{sense} = 500 \times 10^3 \times Q [Ah] / C_0 [nF]; (V_{CC} = 2.4\text{ V})$$

(13.3)

As can be seen from formula (13.3), it is the battery size that is of importance and not the discharge time. Some examples are given in Table 3.

State-of-charge indicator for NiMH and NiCd powered applications

SAA1500T

Table 2 Charge components.

NiXX / xxAh				
charge time (h)	1/3	1/2	1	
charge current (CA)	3	2	1	
fixed frequency (kHz)	6.1	4.1	2.05	formula 13.1
R_o (k Ω) ($C_o = 1.2$ nF); note 1	180	264	556	formula 9.1
R_o (k Ω) ($C_o = 2.4$ nF); note 1	90	132	277	
trickle charge current (CA)	$1/32 \times I_{charge}$			
self-discharge current (CA)	$1/150 \times I_{trickle}$			

Note

- $C_o > 1.2$ nF because of the parasitic capacitance influence on the printed-circuit board.

Table 3 Discharge components.

	NiCd		NiMH	
	AA(600mAh)	Sub C(1.2Ah)	AA(1.1Ah)	AA(1.7Ah)
$R_{conv}/R_{sense}(C_o = 1.2$ nF)	252k	499k	459k	706k
$R_{conv}/R_{sense}(C_o = 2.4$ nF)	126k	252k	229k	352k
$R_{conv}(C_o = 1.2$ nF) ($R_{sense} = 70$ m Ω)	17k6	34k8	32k	49k3
$R_{conv}(C_o = 2.4$ nF) ($R_{sense} = 70$ m Ω)	8k8	17k4	16k	24k6

State-of-charge indicator for NiMH and NiCd powered applications

SAA1500T

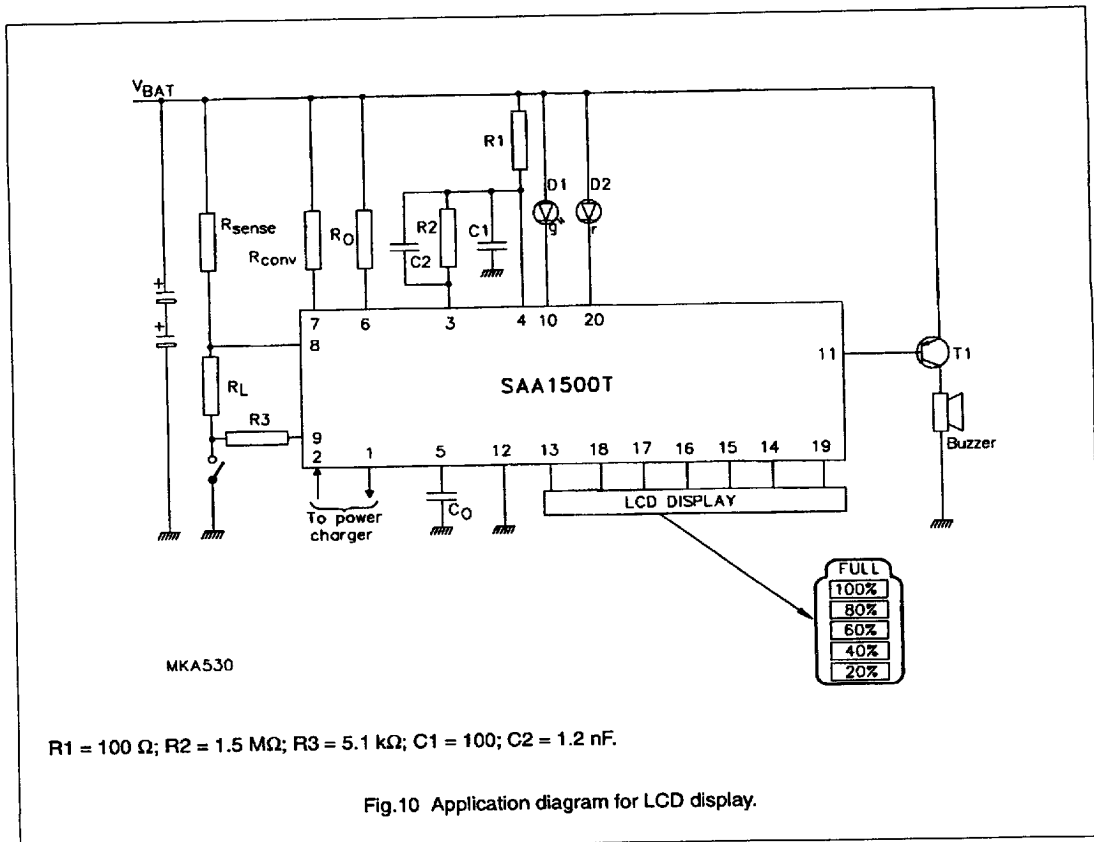

State-of-charge indicator for NiMH and NiCd powered applications

SAA1500T

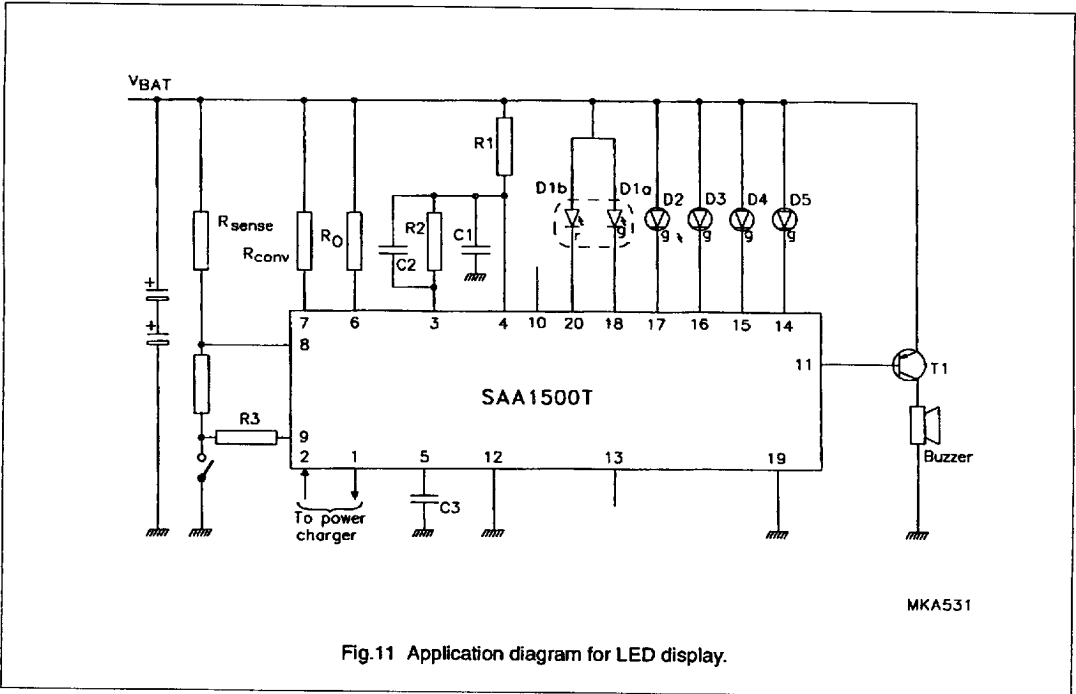

APPENDIX A

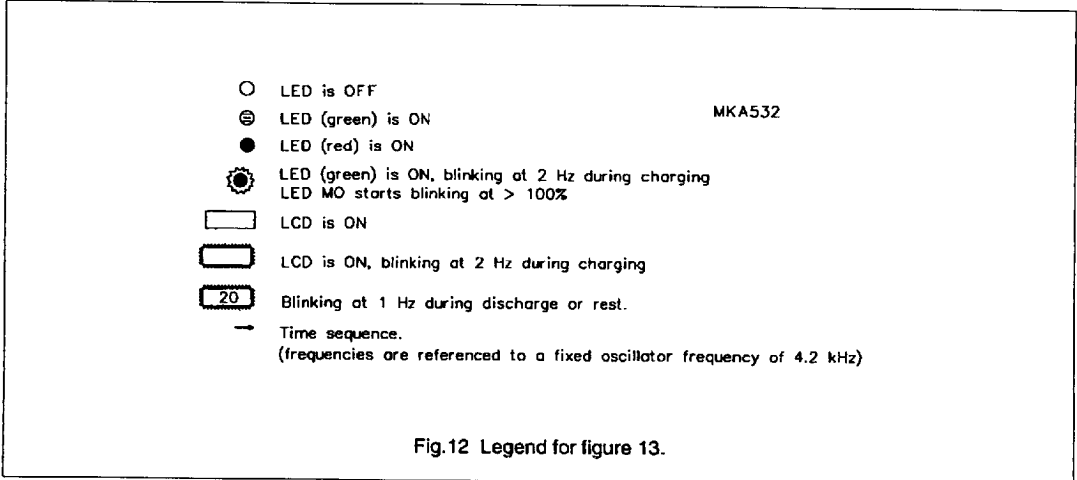

State-of-charge indicator for NiMH and NiCd powered applications

SAA1500T

APPENDIX B

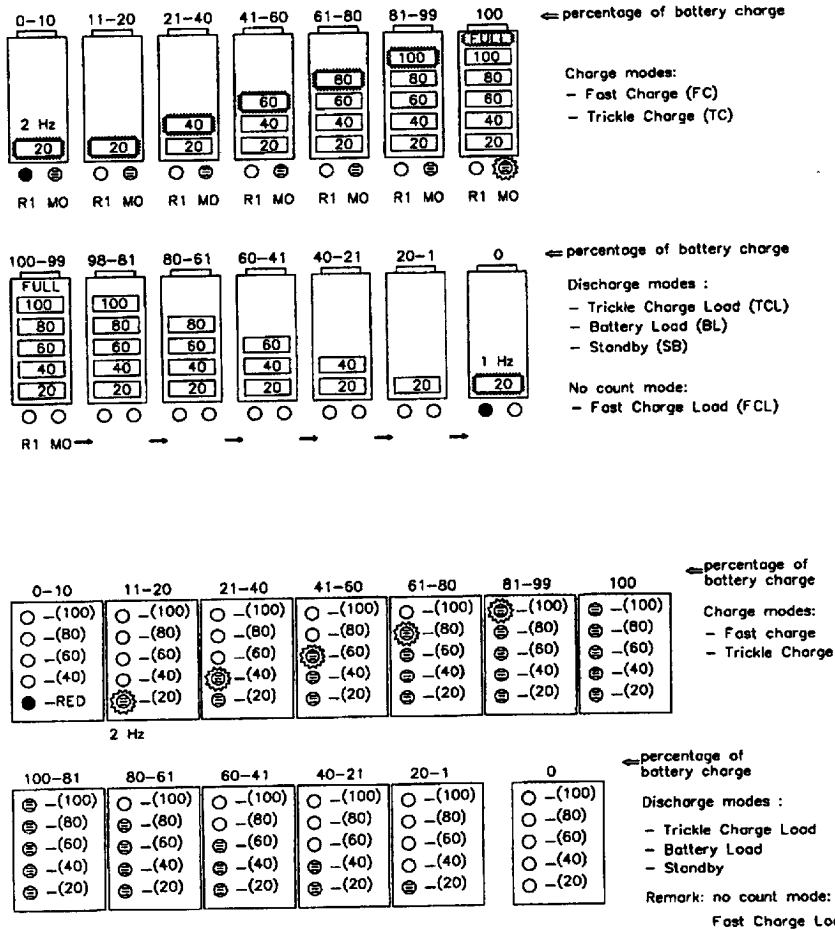

MKA533

Fig. 13 Battery charge displayed by LCD and LED.



State-of-charge indicator for NiMH and NiCd powered applications**SAA1500T****Remarks to figure 13****LED mode**

The LEDs are activated at every operational mode change. If the LEDs were already active before the mode change, the display will not be changed. If the LEDs were not active before the mode change, a step-up pattern is generated. Step up means that the LEDs are activated successively recording the charge status every 1/8 second. In the Battery Load, Trickle Charge Load and Standby modes, the LEDs are switched off after 8 second. In the Fast Charge, Trickle Charge and Fast Charge Load modes, the LEDs remain on.

Battery Low Indication is active if;

The charging (FC, TC) is stopped (==> standby) before 10% charge is reached.

The discharging (BL, TCL) is started below 10% and stopped (==> SB) above 0%.

The discharging is stopped (==>) at 0%.

For BLI waveforms (see Fig.9) R1 is active before the mode is switched over to standby.

Battery Low Indication is not active if;

Discharging is started above 10% and stopped 10-1%. Instead, the green L20 LED will be active for 8 seconds. If recharging is started during 1-10%. The L20 LED is blinking at 2 Hz, the red LED is not active.

LCD mode

The LCD display, as against the LED mode, is always visible.

Battery Low Indication is active if:

The charging (FC, TC) is stopped (==> standby) before 10% charge is reached.

The discharging (BL, TCL) is stopped (==> SB) at 0% charge.