

| REV | DESCRIPTION | DATE | BY |
|-----|-------------|----------|-----|
| A | NEW DRAWING | 11/13/08 | JAG |

F8123

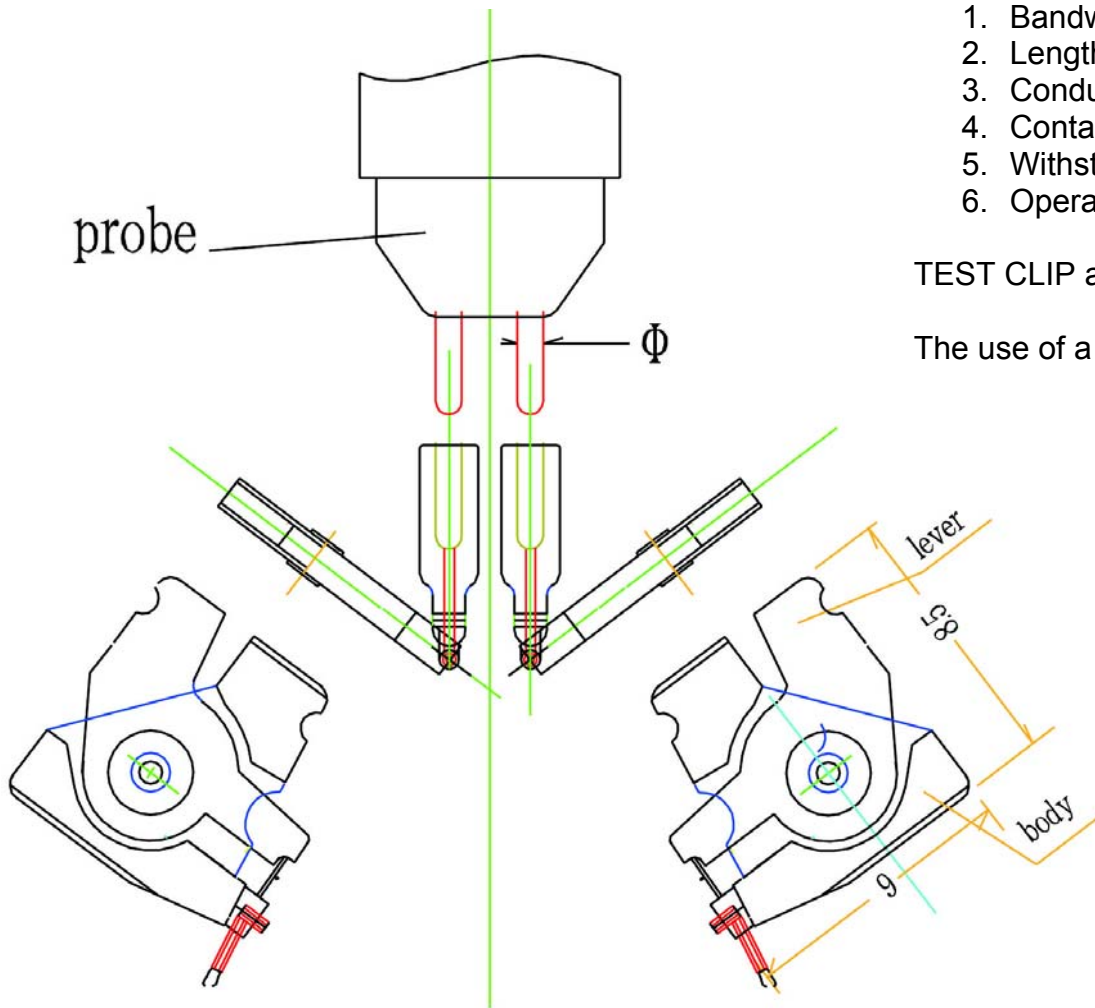

NOTES

1. Bandwidth: HIGH-SPEED, DC ~15GHz
2. Length of current-carrying part: 2~5mm
3. Conductor resistance: 3mΩ
4. Contact resistance: 10mΩ
5. Withstanding voltage: 80VDC
6. Operating temperature rating: 0°C ~ 80°C (no condensation)

TEST CLIP allows electrode to bend 10°.

The use of a magnifying glass is advised when looking at the tip.

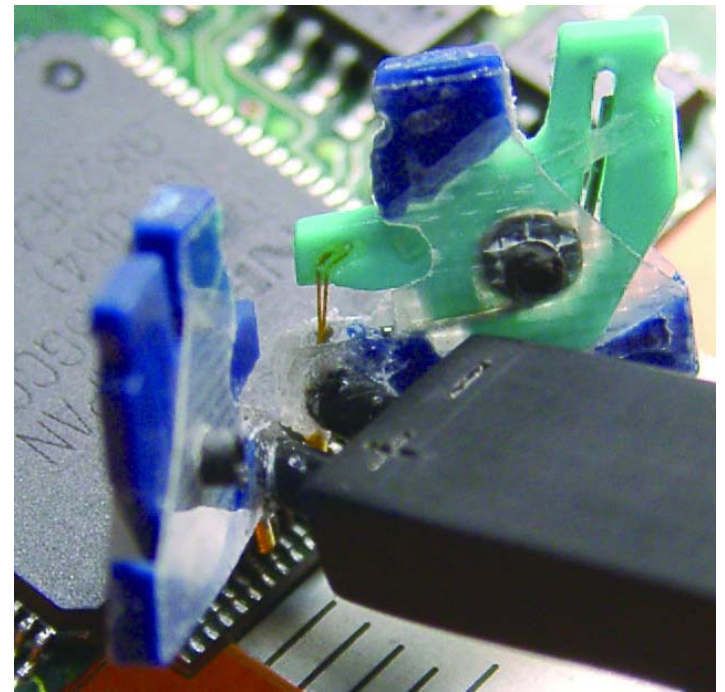

| Item # | Accessible IC Pitch | Probe Side Pin Contact Size Φ | Color | |
|----------|---------------------|-------------------------------|-------|-------|
| | | | Body | Lever |
| FPN-DMFR | 0.65 ~ 1.25 | 0.65 ~ 0.86 | Blue | Blue |
| FPN-DSFR | 0.3 ~ 0.65 | 0.65 ~ 0.86 | Red | Blue |
| FPN-DMKR | 0.65 ~ 1.25 | 0.38 ~ 0.64 | Blue | Blue |
| FPN-DSKR | 0.3 ~ 0.65 | 0.38 ~ 0.64 | Red | Blue |
| FPN-DMFL | 0.65 ~ 1.25 | 0.65 ~ 0.86 | Blue | Green |
| FPN-DSFL | 0.3 ~ 0.65 | 0.65 ~ 0.86 | Red | Green |
| FPN-DMKL | 0.65 ~ 1.25 | 0.38 ~ 0.64 | Blue | Green |
| FPN-DSKL | 0.3 ~ 0.65 | 0.38 ~ 0.64 | Red | Green |

ALL DIMENSIONS ARE IN MILLIMETERS UNLESS OTHERWISE SPECIFIED

EMULATION TECHNOLOGY, INC.
 VLSI and SMT ADAPTERS and ACCESSORIES

759 FLYNN ROAD
 CAMARILLO, CA 93012
 TEL: (805) 383-8480
 FAX: (805) 383-8484

SHEET: 1 OF 1 DATE: 11/13/08 REVISION: A **ASSEMBLY DRAWING**

CHECKED: PREPARED BY: J. GELACIO ITEM: FPN-DXYZ

DESCRIPTION: SOCKET SIDE TYPE

DO NOT SCALE DRAWING