

REV	DESCRIPTION	DATE	BY
A	NEW DRAWING	11/13/08	JAG

F8125

NOTES

1. Bandwidth: HIGH-SPEED, DC ~15GHz
2. Length of current-carrying part: 2~5mm
3. Conductor resistance: 3mΩ
4. Contact resistance: 10mΩ
5. Withstanding voltage: 80VDC
6. Operating temperature rating: 0°C ~ 80°C (no condensation)

TEST CLIP allows electrode to bend 10°.

The use of a magnifying glass is advised when looking at the tip.

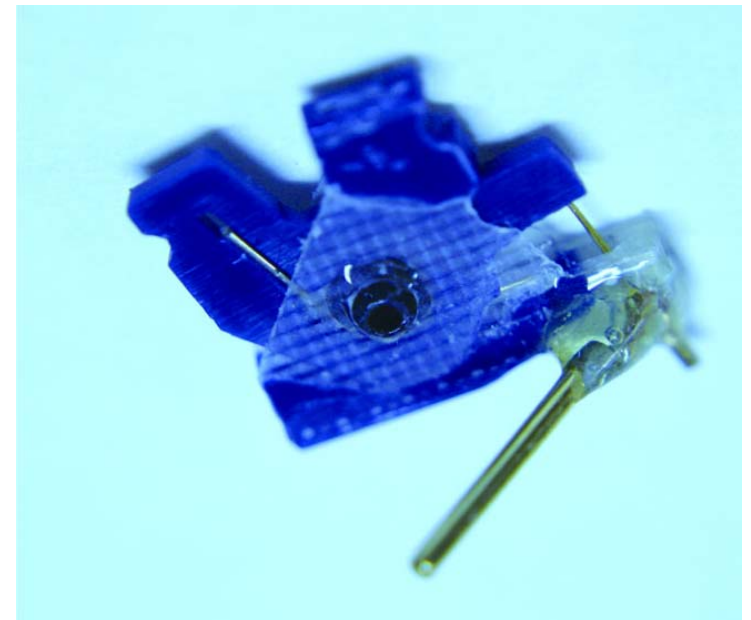
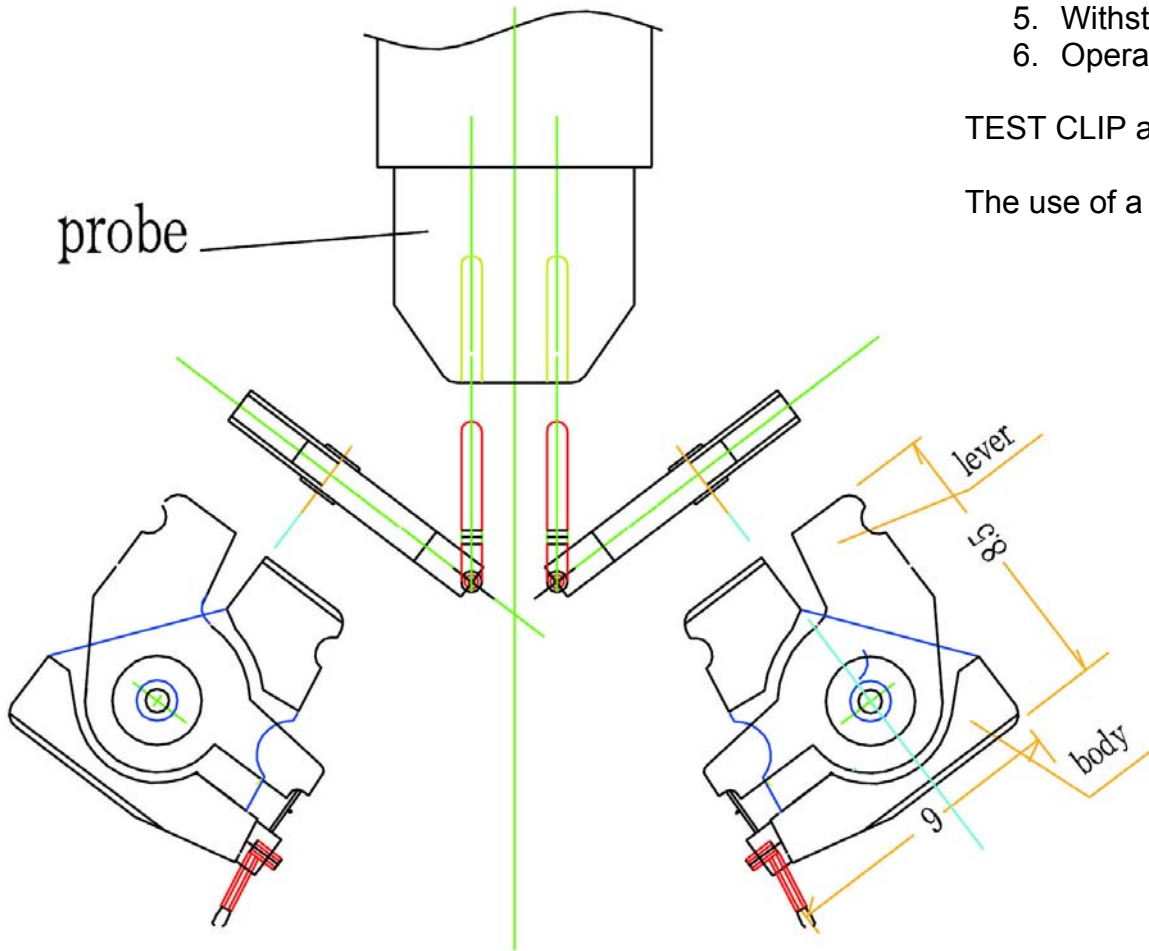

Item #	Accessible IC Pitch	Color	
		Body	Lever
FPN-DMNR	0.65 ~ 1.25	Blue	Blue
FPN-DSNR	0.3 ~ 0.65	Red	Blue
FPN-DMNL	0.65 ~ 1.25	Blue	Green
FPN-DSNL	0.3 ~ 0.65	Red	Green

ALL DIMENSIONS ARE IN MILLIMETERS UNLESS OTHERWISE SPECIFIED

	EMULATION TECHNOLOGY, INC.		
	VLSI and SMT ADAPTERS and ACCESSORIES		
759 FLYNN ROAD CAMARILLO, CA 93012		TEL: (805) 383-8480 FAX: (805) 383-8484	
SHEET: 1 OF 1	DATE: 11/13/08	REVISION: A	ASSEMBLY DRAWING
CHECKED:	PREPARED BY: J. GELACIO		ITEM: FPN-DXNY
DO NOT SCALE DRAWING			DESCRIPTION: PIN SIDE TYPE