

Metal Carbon Composite Tubular Resistors
Non-inductive, Ultra High Voltage, High Energy type

VOICE : +82-31-429-6379
 FAX : +82-31-429-9127
 E-MAIL : info@3RLab.com



ET; Energy Tube; high voltage,high energy, high frequency in Low Ohmic

ET is furnace in hydrogen environment for long time. Using individual-resistors, especially for R-Tank, and RC-Tank , in Air, in Oil , forced Oil fluently flow through inner & outside of resistors.

Advanced of Anti-Corona-Contact sys. between Caps to Resistives in Axial-Adhesive

- Able to build up Mega Jouls Energy
- Pulse Modulators
- Ultra Surge Absorb
- HV Cap Charging / Discharging
- Nuclear, Nuclear Fusion
- High Voltage Plasma De-Pollution Gas Systems
- High Voltage Rectifier, Diode
- High Frequency
- Military; High Voltage Ultra Energy Dummy Loads

DIMENSIONS [mm]

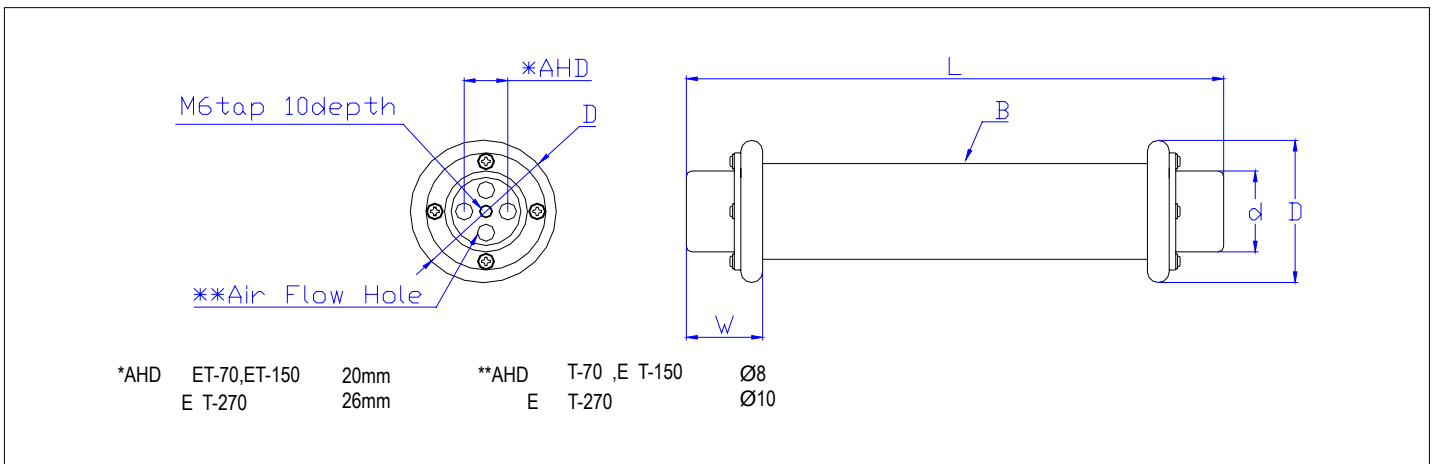

Model Nr.	Power [W] ¹⁾	Energy ²⁾ [J] Max.	Max.Impulse Voltage ³⁾ [kV] 1.2/50uSec	Ohmic Rating [Ω]			Dimensions in millimeters				
				Std. Rating	Low Extend	Hi- Extend	L	B	D	d	W
ET-70	70	6,790	50	10-250	1.5	5k	186+/-2	45+/-1.5	67+/-0.5	38+/-0.5	35+/-1
ET-150	150	14,500	100	10-500	2	20k	312+/-2	45+/-1.5	67+/-0.5	38+/-0.5	35+/-1
ET-270	270	30,000	150	10-500	2	20k	423+/-3	60+/-2.0	81.5+/-0.5	48+/-0.5	40+/-1

* Custom design and specification available upon request related with q'ty basis
 Notes : "1)" limited by chart 2 & chart 3 & Specification. "2)" "3)" limited by chart 1 & chart 4 & Specification

Metal Carbon Composite Tubular Resistors Non-inductive, Ultra High Voltage, High Energy type

VOICE : +82-31-429-6379
FAX : +82-31-429-9127
E-MAIL : info@3RLab.com

Specific ohmic vs. withstand voltage [1.2/50uSec] co-relations (chart 1)

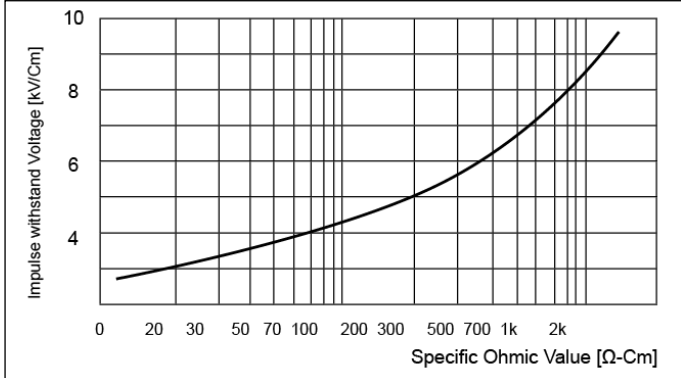

Power derating at continuous loading (chart 2)

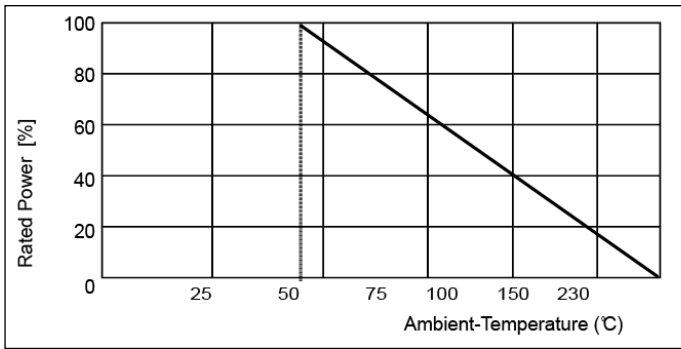

Surface temp. rising & power rate (chart 3)

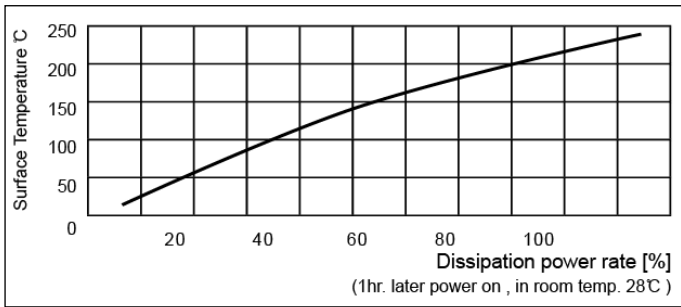

Surface temp. rising & power rate (chart 3)

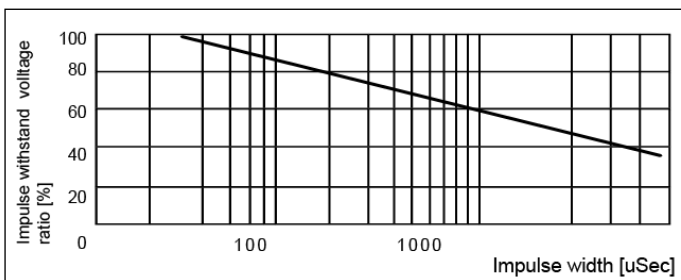

SPECIFICATIONS

Standard Resistance of Toelrance: 20% (15% , 10%, 5% if stocked)

Rated power and power derated : The rated power working at 40 °C . In case of exceed 40 or the individual resistors are on thermal radiation, then the continuous working power must be reduced to 10% ~ 90% of the rated power typ. recommended.

Surface temperature control : In case of continuous working condition , the surface temperature shall be controlled,keep 100 °C max. An enforced coolant fan or other air coolant must be operate before the resistors working. Water or other chemical fluid what prohibited direct pour in the surface of resistors .

Short time operational surface temperature : 250°C max. for sveral mins. {harsh temperature to broken on just resistives : 500°C max. for 30min (must be slowly increased for 20mins) but core shaft made of enforced epoxy and bent/out of order from 230C }

Corona Ring and Cap : ET-series supplied in the resistors put on standard corona ring and cap basically. The specified standard cap and corona ring system to optimize at 50% of the rated V-peak on ≤1.5/50μs pulse. So, in case of higher voltages and longer pulse shapes would better use specific corona ring and cap. Especially for the individual resistors what are less than 20R ,which shall be recommended, to optimized on custom ring and cap /electrods , please talk with 3RLab Engrs.

Gap distance of multi conection in parralell and power derate: more than 4ea ,must keep distance between each resistors, because each resistors hit radiation on themselves.

gd=1.5 x B ; derate to 60% of rated power

gd=2.0 x B ; derate to 70% of rated power

gd=2.5 x B ; derate to 80% of rated power

cf. dg = gap distance of center to center between each resistors

B = resistors body diameter

Temperature Coefficient of Resistance ,TCR : 0.15%/°C typ.

Voltage Coefficient of Resistance ,typ. VCR :

1.5% [kV/Cm] at 2R~ 500R ,, 2.5% [kV/Cm] at 600R~1.5kΩ,, 5% [kV/Cm] at higher than 1.6 kΩ .

Load Life Stability : ΔR5% max. at dissipation(less than 50% of rated max power), ΔR7% at 100% of rated power, for 500h. *The Long Life stability (on Load) and power yield is one of very co-related factor . Recommended dissipate electric power/energy from 10% to 50% of rated power and energy, voltage. Example, long life of several years required ;load on resistors clearly less than rated power , energy, voltage. Otherwise, just one of short time(1 or 2 times) test application , which might be dissipate full power or higher .*

Short time over load : ΔR2% typ. for 10times of rated Wattage for 5secs.

Short time allowable dissipation energy : 90J/cm³ Max.

Resistives in bulk of Density : 2.55 typ.

Specific Heat of Bulk Resistives : 500~1200J/kg-K typ.

Thermal Conductivity : 1.2W[m-K]

Water coolant type, or oil coolant type custom : please talk with 3RLab Engrs..

Custom design and specification: please talk with 3RLab Engrs..

Cap and Corona Ring of materials : std. Aluminum

cf.: The described specifications & dimensions subject to change without notice.