

## NORIA – the Fiber Bragg Grating Manufacturing Solution

### “Plug & Play” FBG Manufacturing

The NORIA tool is a manufacturing tool to produce Fiber Bragg Gratings (FBGs). A Deep Ultra Violet laser (Coherent Excistar XS 500Hz—ArF) and a phase mask (Ibsen Photonics) are used to transfer a periodic pattern into the core of a photosensitive optical fiber.

The NORIA tool holds a number of different masks in a revolver like holder, each mask having a different pattern periodicity. This flexibility allows the end-user to manufacture FBGs from predefined recipes in an automated fashion.

In addition, multiple FBGs in an array can be written along the fiber at any desired position using the NORIA tools accurate positioning stage.

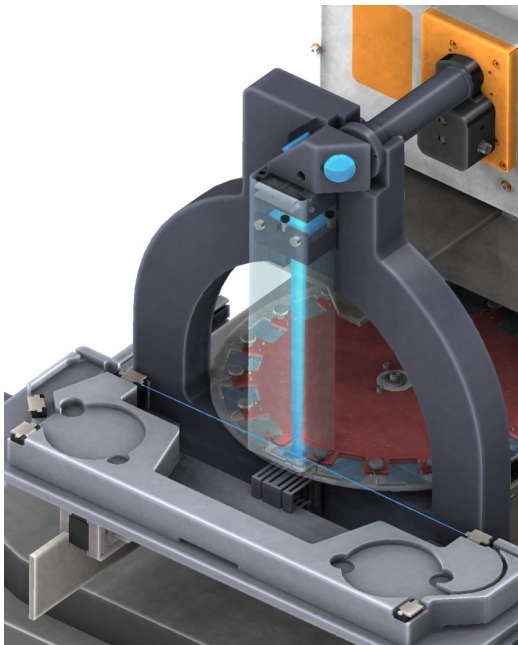

### Sensor Manufacturing Made Easy

- “Plug & Play” system for FBG manufacturing—ready to use after installation
- Write multiple FBG's on a 150 mm length of fiber in one go
- Write uniform or apodized FBGs with a length of 1-10 mm
- Load the NORIA tool with up to 16 phase masks
- Use photo sensitive fibers or hydrogen loaded standard fibers
- Easy to operate and load — fiber fixture system for handling loose fiber and fiber reels (option)
- Solutions for stripping and recoating available as options

## NORIA – Technical Specification

<b>FBG details</b>		
length	10 mm	standard feature. Option for smaller FBG lengths down to 1 mm
Full Width Half Maximum (FWHM)	<150 pm	standard feature, part of predefined recipes
Side Lobe Suppression Ratio (SLSR)	>15 dB	standard feature, part of predefined recipes
default reflection coefficient	>50 %	standard feature, part of predefined recipes
central wavelength repeatability	± 50 pm	central wavelength accuracy is subject to variations in fiber NA from batch to batch
Illumination profile	Gaussian / Tophat	Default Gaussian or Tophat profile. Option to define other profiles
Fiber Outer Diameter (excl. coating)	125 µm	standard feature, option to accommodate smaller and larger OD fibers e.g. 400, 80, 60, 50 and 40 µm
Fiber coating	Acrylate / Polyimide	The fiber needs to be window stripped over a minimum of 20 mm at the desired FBG location.
<b>System details</b>		
Cycle time	<30 s	Cycle time defined as the total amount of time required to write a single highly reflective FBG. Includes fiber positioning, automatic mask selection, exposure and undocking of the fiber.
Available phase mask slots	16	Newly purchased phase masks can easily be inserted manually
Phase masks included	4	By default 4 high quality Ibsen phase-mask are included in the NORIA
Default recipes	4	By default the NORIA has 4 predefined recipes allowing the end-user to manufacture 4 different FBGs in the C-band with approximately 5 nm wavelength separation
User friendly software interface		The software includes a recipe editor allowing the end-user to define FBG recipes.

INFORMATION IS SUBJECT TO CHANGE WITHOUT NOTICE