

# Applying IGBTs



---

# Applying IGBTs

## Application Note

Björn Backlund, Raffael Schnell

Ulrich Schlapbach, Roland Fischer

Evgeny Tsyplakov

ABB Switzerland Ltd

Semiconductors

April 09

### Table of Contents:

<b>1</b>	<b>APPLYING IGBTs</b> .....	<b>3</b>
1.1	INTRODUCTION .....	3
1.2	ELECTRO-STATIC DISCHARGE SENSITIVITY .....	3
<b>2</b>	<b>DATA SHEET USERS GUIDE</b> .....	<b>3</b>
2.1	KEY PARAMETERS AND FEATURES .....	4
2.2	MAXIMUM RATED VALUES .....	5
2.3	IGBT CHARACTERISTIC VALUES .....	7
2.4	DIODE CHARACTERISTICS .....	11
2.5	THERMAL PROPERTIES .....	13
2.6	MECHANICAL PROPERTIES .....	13
2.7	ELECTRICAL CONFIGURATION .....	14
2.8	OUTLINE DRAWING .....	15
2.9	DIAGRAMS .....	15
<b>3</b>	<b>POWER LOSS AND THERMAL CALCULATIONS FOR THE IGBT</b> .....	<b>22</b>
3.1	CALCULATION METHODS .....	22
3.1.1	<i>IGBT loss calculation:</i> .....	22
3.1.2	<i>Diode loss calculation:</i> .....	23
3.1.3	<i>Thermal Calculation:</i> .....	23
3.1.4	<i>Calculations with a Heat sink:</i> .....	24
3.1.5	<i>Transient Overload Calculation:</i> .....	25
3.2	USING THE ABB SIMULATION TOOL .....	27
3.2.1	<i>Program parts</i> .....	27
3.2.2	<i>Creating models</i> .....	33
<b>4</b>	<b>ADDITIONAL NOTES</b> .....	<b>37</b>
4.1	REFERENCES .....	37
4.2	APPLICATION SUPPORT.....	37

---

# 1 Applying IGBTs

## 1.1 Introduction

Due to its controllability, ease of use and high power ratings, the IGBT (Insulated Gate Bipolar Transistor) has become the component of choice for many power electronic applications. It is today possible to build inverters rated to over 1 MW with IGBT-modules without paralleling or serial connecting devices, in a common, 2-level voltage source inverter as shown in Fig. 1.

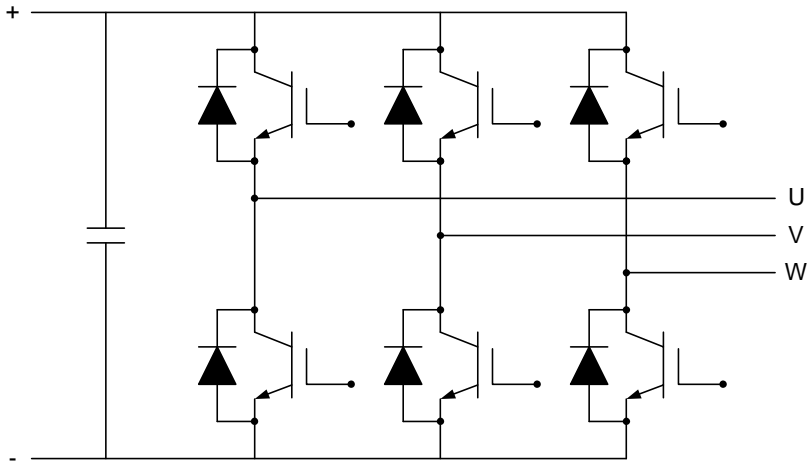

Fig 1 2-level voltage source inverter with IGBTs

To use the IGBT successfully, it is important to understand how both its electrical and thermal parameters are defined. The purpose of this application note is to guide and advise potential users with regards to these two aspects and is correspondingly divided into two sections. The first section is a Data Sheet Users Guide explaining the different parameters and curves included in the ABB IGBT data sheets. The second section describes power loss and thermal calculations of a common PWM-inverter using the ABB simulation tool. Both the data sheets and the simulation tool are available at [www.abb.com/semiconductors](http://www.abb.com/semiconductors).

Even though the IGBT is a non-latching device it has been designed for switching operation and should not be used in its linear operation mode.

This application note does not cover any direct semiconductor physics. For a systematic introduction to the operation principle and physics of power semiconductor devices, including the IGBT, we recommend the book "Power Semiconductors" from Stefan Linder, ISBN 0-8247-2569-7 (CRC Press, published in 2006).

## 1.2 Electro-static discharge sensitivity

The IGBT is an electrostatic sensitive device and must be handled properly to avoid damage from electro static discharge (ESD). Therefore, please observe the international standard IEC 60747-1 chapter IX. The ABB HiPak-family has been designed and qualified for industrial level.

## 2 Data sheet users guide

This section is a detailed guide to the proper understanding of an IGBT data sheet. Parameters and ratings will be defined and illustrated by figures, where appropriate, while following the sequence in which parameters appear in the data sheet. For explanation purposes, data and diagrams associated with IGBT type 5SNA 1200E330100 have been used, but because IGBTs have similar data sheets, this guide is applicable to all IGBTs.

The data sheets distinguish between maximum rated values and characteristic values. Maximum values indicate limits beyond which damage may occur to the device. Characteristic values are parameters defined under typical application conditions.

ABB reserves the right to change data sheets without notice. Therefore, for the latest version, please visit our website at [www.abb.com/semiconductors](http://www.abb.com/semiconductors).

## 2.1 Key parameters and features

$V_{CE}$  = 3300 V

$I_C$  = 1200 A

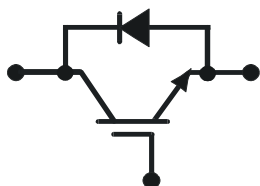

**ABB HiPak™**

**IGBT Module**

**5SNA 1200E330100**

Doc. No. 5SYA1556-03 May 05

- **Low-loss, rugged SPT chip-set**
- **Smooth switching SPT chip-set for good EMC**
- **Industry standard package**
- **High power density**
- **AlSiC base-plate for high power cycling capability**
- **AlN substrate for low thermal resistance**



The key features give the basic voltage and current rating of the module together with a connection diagram. They are followed by a short description of the technologies used, the main features of these technologies and a picture of the module.

## 2.2 Maximum rated values

### Maximum rated values <sup>1)</sup>

Parameter	Symbol	Conditions	min	max	Unit
Collector-emitter voltage	$V_{CES}$	$V_{GE} = 0 \text{ V}$ , $T_{vj} \geq 25 \text{ °C}$		3300	V
DC collector current	$I_C$	$T_c = 80 \text{ °C}$		1200	A
Peak collector current	$I_{CM}$	$t_p = 1 \text{ ms}$ , $T_c = 80 \text{ °C}$		2400	A
Gate-emitter voltage	$V_{GES}$		-20	20	V
Total power dissipation	$P_{tot}$	$T_c = 25 \text{ °C}$ , per switch (IGBT)		11750	W
DC forward current	$I_F$			1200	A
Peak forward current	$I_{FRM}$			2400	A
Surge current	$I_{FSM}$	$V_R = 0 \text{ V}$ , $T_{vj} = 125 \text{ °C}$ , $t_p = 10 \text{ ms}$ , half-sinewave		12000	A
IGBT short circuit SOA	$t_{psc}$	$V_{CC} = 2500 \text{ V}$ , $V_{CEMCHIP} \leq 3300 \text{ V}$ $V_{GE} \leq 15 \text{ V}$ , $T_{vj} \leq 125 \text{ °C}$		10	$\mu\text{s}$
Isolation voltage	$V_{isol}$	1 min, $f = 50 \text{ Hz}$		6000	V
Junction temperature	$T_{vj}$			150	$^{\circ}\text{C}$
Junction operating temperature	$T_{vj(op)}$		-40	125	$^{\circ}\text{C}$
Case temperature	$T_c$		-40	125	$^{\circ}\text{C}$
Storage temperature	$T_{stg}$		-40	125	$^{\circ}\text{C}$
Mounting torques <sup>2)</sup>	$M_s$	Base-heatsink, M6 screws	4	6	Nm
	$M_{t1}$	Main terminals, M8 screws	8	10	
	$M_{t2}$	Auxiliary terminals, M4 screws	2	3	

<sup>1)</sup> Maximum rated values indicate limits beyond which damage to the device may occur per IEC 60747

<sup>2)</sup> For detailed mounting instructions refer to ABB Document No. 5SYA2039

**$V_{CES}$ :** *Collector-emitter voltage.* Maximum voltage that under *any* conditions should be applied between collector and emitter. Applying voltages to the module in excess of this limit, even of short duration, can lead to device failure.

The collector – emitter voltage has a temperature dependency. Most ABB devices have been designed to have full blocking voltage within the total operating temperature range but there are a few exceptions where the temperature range across which the rated voltage is valid, is reduced. This is shown in the data sheet at conditions where the temperature range for the rated blocking voltage is specified. For temperatures below the given range, the blocking voltage decreases by about 0.11 %/K.

High DC voltages applied to any semiconductor will provoke high failure rates due to cosmic radiation. For this reason, the operating DC voltage is much lower than the peak repetitive voltage  $V_{CES}$  defined above. This is explained and specified in Application Note 5SYA2042. For design voltage recommendations see document 5SYA2051.

**$I_C$ :** *DC collector current.* Maximum DC-current that the IGBT-part of the module can conduct at the given conditions. Exceeding this limit will lead to over-heating of the device.

**$I_{CM}$ :** *Peak collector current.* Maximum peak current that the IGBT can switch within the limits given in Fig. 11. Exceeding this limit may lead to turn-off failures and (depending on pulse duration) also to over-heating of the device.

**$V_{GES}$ :** *Gate-emitter voltage.* Absolute maximum allowable voltage between gate and emitter under any conditions. Exceeding the given limits may lead to degradation of the gate oxide, ultimately leading to device failure.

---

**P<sub>tot</sub>**: *Total power dissipation*. Maximum allowed power loss dissipated in the IGBT-part of the module at given conditions. It can be calculated at different case temperatures using Equation 1:

$$P_{tot} = \frac{T_j - T_c}{R_{th(j-c)IGBT}} \quad \text{Equation 1}$$

**I<sub>F</sub>**: *DC forward current*. Maximum DC-current that the diode part of the module can conduct at the given conditions. Exceeding this limit will lead to over-heating of the device.

**I<sub>FRM</sub>**: *Peak forward current*. Maximum peak current that the diode part of the module can conduct.

**I<sub>FSM</sub>**: *Surge current*. Maximum non-repetitive surge current is the maximum allowed pulse-width-dependent peak value of a half-sinusoidal surge current, applied at an instant when the diode is operating at its maximum junction temperature. Though a single surge at the given conditions does not cause any irreversible damage to the module, it should not occur too frequently due to the thermal stress applied to the module during the surge.

During a surge, the junction heats up to a temperature well above its rated maximum values such that the diode is no longer able to block rated voltage; the surge current values are therefore only valid when no voltage is reapplied after the surge.

**t<sub>pSC</sub>**: *IGBT Short Circuit SOA*. Maximum duration of a short-circuit current pulse through the IGBT at the given conditions. Exceeding this duration will over-heat the device and cause a failure. It determines the limit for the time allowed for possible fault detection and turn-off via the gate unit.

**V<sub>isol</sub>**: *Isolation voltage*. Maximum applied voltage between the electrically conductive parts of the module (terminals) and the insulated base plate at the given conditions. All devices are tested at the given conditions before delivery.

For insulation coordination purposes, please consult applicable national standards for the equipment's intended area of use /e.g. IEC 60146.

All ABB modules are in addition to the isolation voltage rated for partial discharge (PD). The used rating is:

**U<sub>e</sub>**: *Partial discharge extinction voltage*. The lowest peak value of the test voltage at which the apparent charge becomes less than the specified discharge magnitude, normally 10 pC at f = 50 Hz tested according to IEC 61287, when the test voltage is reduced below a high level where such discharges have occurred. The device limit is available upon request, if not given in the data sheet.

**T<sub>vj</sub>**: *Junction temperature*. The IGBT and Diode chips used in the module are capable of operating at temperatures up to the specified limit.

**T<sub>vj(op)</sub>**: *Junction operating temperature*. The limitation for the operating temperatures mainly emanates from the properties of the organic materials used in the modules. Operating outside the specified temperature window may degrade the module's materials, leading, for instance, to increased partial discharge.

**T<sub>C</sub>**: *Case temperature*. As in the case of **T<sub>vj(op)</sub>**, the case temperature must be within the specified limits. This is a smaller restriction than the operating junction temperature since, in practice, the case will always be well below the maximum junction temperature in order to sink the heat.

**T<sub>stg</sub>**: *Storage temperature*. The possible temperature-dependent degradation of the module's materials may also occur at storage conditions and therefore the storage temperature must be kept within the same limits as the operating temperature.

**M<sub>s</sub>**: *Mounting torque base-to-heat-sink*. Recommended mounting torque for the bolts fastening the module to the heat sink. For details about mounting see Mounting Instruction 5SYA2039.

**M<sub>t1</sub>**: *Mounting torque main terminals*. Recommended mounting torque for the bolts fastening the bus-bars to the main current terminals. For details about mounting, see Mounting Instruction 5SYA2039. Note that ABB HiPak-modules are delivered without mounting bolts for the main terminals. The reason for this is that the correct length of the terminal bolts depends on the user's bus-bar thickness: an inadequate bolt length will strip the terminal nut threads; an excessive bolt length will puncture the module lid.

**M<sub>12</sub>**: *Mounting torque auxiliary terminals*. Recommended mounting torque for the bolts fastening the gate unit connections to the control terminals on the module. For details about mounting see Mounting Instruction 5SYA2039.

## 2.3 IGBT characteristic values

The characteristic values are divided into static and dynamic values.

### IGBT characteristic values <sup>3)</sup>

Parameter	Symbol	Conditions	min	typ	max	Unit	
Collector (-emitter) breakdown voltage	$V_{(BR)CES}$	$V_{GE} = 0 \text{ V}$ , $I_C = 10 \text{ mA}$ , $T_{vj} = 25 \text{ °C}$	3300			V	
Collector-emitter <sup>4)</sup> saturation voltage	$V_{CE \text{ sat}}$	$I_C = 1200 \text{ A}$ , $V_{GE} = 15 \text{ V}$	$T_{vj} = 25 \text{ °C}$	2.7	3.1	3.4	V
			$T_{vj} = 125 \text{ °C}$	3.5	3.8	4.3	V
Collector cut-off current	$I_{CES}$	$V_{CE} = 3300 \text{ V}$ , $V_{GE} = 0 \text{ V}$	$T_{vj} = 25 \text{ °C}$			12	mA
			$T_{vj} = 125 \text{ °C}$			120	mA
Gate leakage current	$I_{GES}$	$V_{CE} = 0 \text{ V}$ , $V_{GE} = \pm 20 \text{ V}$ , $T_{vj} = 125 \text{ °C}$	-500		500	nA	
Gate-emitter threshold voltage	$V_{GE(TO)}$	$I_C = 240 \text{ mA}$ , $V_{CE} = V_{GE}$ , $T_{vj} = 25 \text{ °C}$	5.5		7.5	V	
Gate charge	$Q_{ge}$	$I_C = 1200 \text{ A}$ , $V_{CE} = 1800 \text{ V}$ , $V_{GE} = -15 \text{ V} \dots 15 \text{ V}$		12.1		$\mu\text{C}$	
Input capacitance	$C_{ies}$	$V_{CE} = 25 \text{ V}$ , $V_{GE} = 0 \text{ V}$ , $f = 1 \text{ MHz}$ , $T_{vj} = 25 \text{ °C}$		187		nF	
Output capacitance	$C_{oes}$			11.57			
Reverse transfer capacitance	$C_{res}$			2.22			

<sup>3)</sup> Characteristic values according to IEC 60747 – 9

<sup>4)</sup> Collector-emitter saturation voltage is given at chip level

**$V_{(BR)CES}$** : *Collector (-emitter) breakdown voltage*. Minimum voltage that the device will block in the forward direction at the specified conditions.

**$V_{CE \text{ sat}}$** : *Collector-Emitter saturation voltage*. Collector-emitter voltage at the specified conditions. It is given at “chip level” including the resistance in the bonding wires but *not* including the resistances in the terminals (separately specified).

**$I_{CES}$** : *Collector cut-off current*. Collector current at the specified collector-emitter voltage with the gate short-circuited to the emitter.

**$I_{GES}$** : *Gate leakage current*. Gate leakage current at the specified gate-emitter voltage with the collector short-circuited to the emitter.

**$V_{GE(TO)}$** : *Gate-Emitter threshold voltage*. Gate-emitter voltage at which the collector current attains the specified value.

**$Q_{GE}$** : *Gate charge*. Charge required to raise the gate voltage from the specified minimum to the specified maximum value of  $V_{GE}$  at the given conditions.

**$C_{ies}$** : *Input capacitance*. Capacitance between the gate and the emitter terminals with the collector terminal short-circuited to the emitter terminal.

**$C_{oes}$** : *Output capacitance*. Capacitance between the collector and the emitter terminals with the gate terminal short-circuited to the emitter terminal.

**$C_{res}$** : *Reverse transfer capacitance*. Capacitance between the collector and the gate terminals.

Turn-on delay time	$t_{d(on)}$	$V_{CC} = 1800 \text{ V},$ $I_C = 1200 \text{ A},$ $R_G = 1.5 \Omega,$	$T_{vj} = 25 \text{ }^\circ\text{C}$	400	ns
			$T_{vj} = 125 \text{ }^\circ\text{C}$	400	
Rise time	$t_r$	$V_{GE} = \pm 15 \text{ V},$ $L_\sigma = 100 \text{ nH},$ inductive load	$T_{vj} = 25 \text{ }^\circ\text{C}$	175	ns
			$T_{vj} = 125 \text{ }^\circ\text{C}$	200	
Turn-off delay time	$t_{d(off)}$	$V_{CC} = 1800 \text{ V},$ $I_C = 1200 \text{ A},$ $R_G = 1.5 \Omega,$	$T_{vj} = 25 \text{ }^\circ\text{C}$	940	ns
			$T_{vj} = 125 \text{ }^\circ\text{C}$	1070	
Fall time	$t_f$	$V_{GE} = \pm 15 \text{ V},$ $L_\sigma = 100 \text{ nH},$ inductive load	$T_{vj} = 25 \text{ }^\circ\text{C}$	350	ns
			$T_{vj} = 125 \text{ }^\circ\text{C}$	440	
Turn-on switching energy	$E_{on}$	$V_{CC} = 1800 \text{ V}, I_C = 1200 \text{ A},$ $V_{GE} = \pm 15 \text{ V}, R_G = 1.5 \Omega,$ $L_\sigma = 100 \text{ nH},$ inductive load	$T_{vj} = 25 \text{ }^\circ\text{C}$	1340	mJ
			$T_{vj} = 125 \text{ }^\circ\text{C}$	1890	
Turn-off switching energy	$E_{off}$	$V_{CC} = 1800 \text{ V}, I_C = 1200 \text{ A},$ $V_{GE} = \pm 15 \text{ V}, R_G = 1.5 \Omega,$ $L_\sigma = 100 \text{ nH},$ inductive load	$T_{vj} = 25 \text{ }^\circ\text{C}$	1420	mJ
			$T_{vj} = 125 \text{ }^\circ\text{C}$	1950	
Short circuit current	$I_{SC}$	$t_{psc} \leq 10 \mu\text{s}, V_{GE} = 15 \text{ V}, T_{vj} = 125 \text{ }^\circ\text{C},$ $V_{CC} = 2500 \text{ V}, V_{CEM CHIP} \leq 3300 \text{ V}$		5000	A
Module stray inductance	$L_{\sigma CE}$			10	nH
Resistance, terminal-chip	$R_{CC'+EE'}$		$T_C = 25 \text{ }^\circ\text{C}$	0.06	m $\Omega$
			$T_C = 125 \text{ }^\circ\text{C}$	0.085	

All switching parameters are defined in a phase-leg connection using an auxiliary component of the same type as the device under test (DUT), see Fig. 2. For the definitions of the different switching parameters, see Figs 3 and 4. All switching parameters in ABB data sheets are specified for an inductive load.

Note that other manufacturers may use a different definition for the IGBT switching parameters. This must be considered when comparing modules from different suppliers.

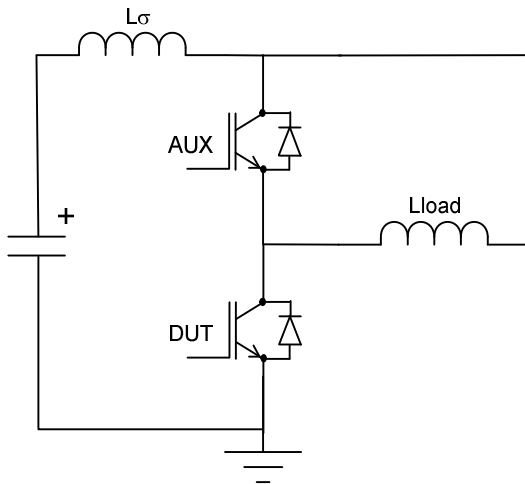

Fig. 2 Electrical circuit for testing of the dynamic performance of the IGBT

**$t_{d(on)}$ :** *Turn-on delay time.* The turn-on delay time is defined as the time between the instant when the gate voltage has reached 10 % of its final value and the instant when the collector current has reached 10 % of its final value.

**$t_r$ :** *Rise time.* The rise time is defined as the time between instants when the collector current has risen from 10 % to 90 % of its final value.

The total turn-on time  $t_{on}$  is the sum of  $t_{d(on)}$  and  $t_r$ .



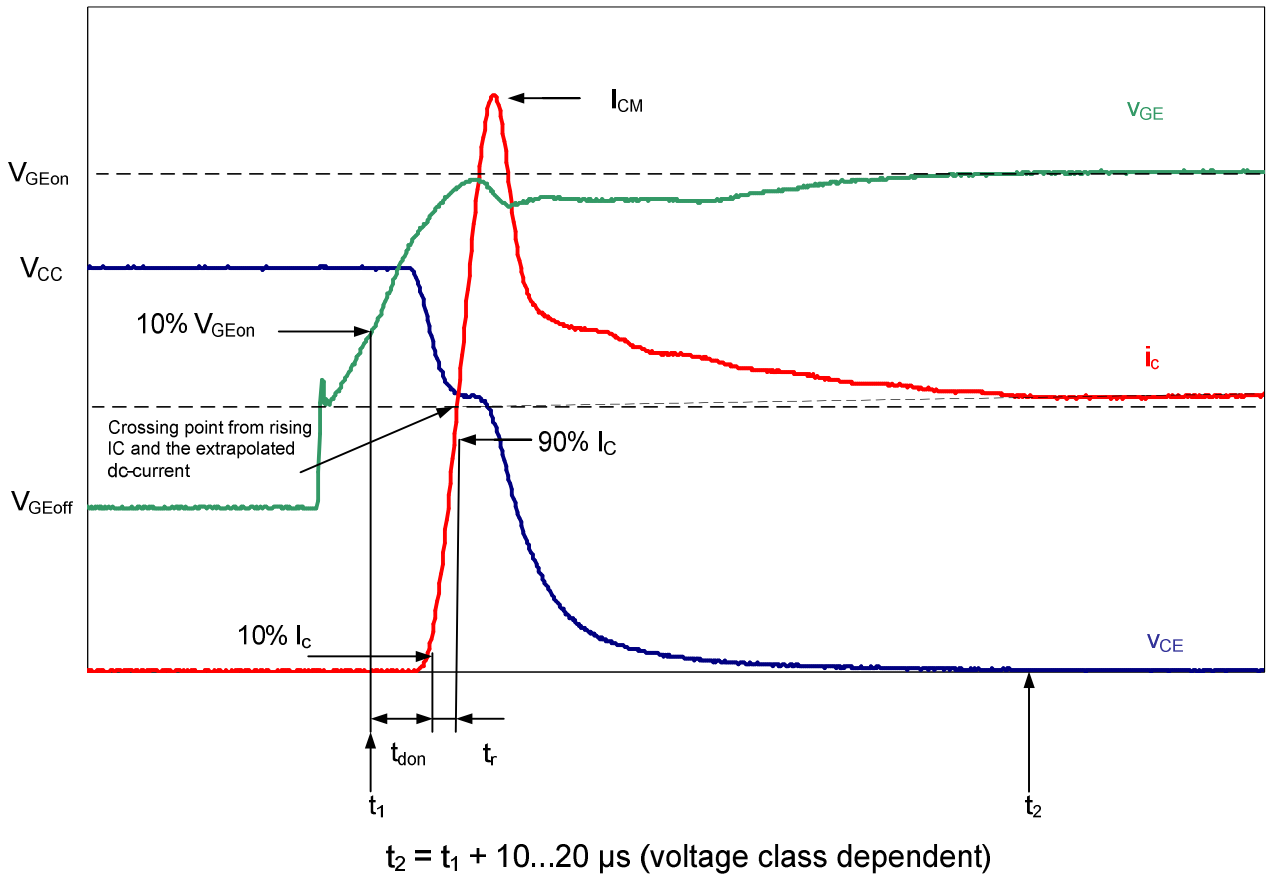

Fig. 3 Definitions of the turn-on parameters for the IGBT

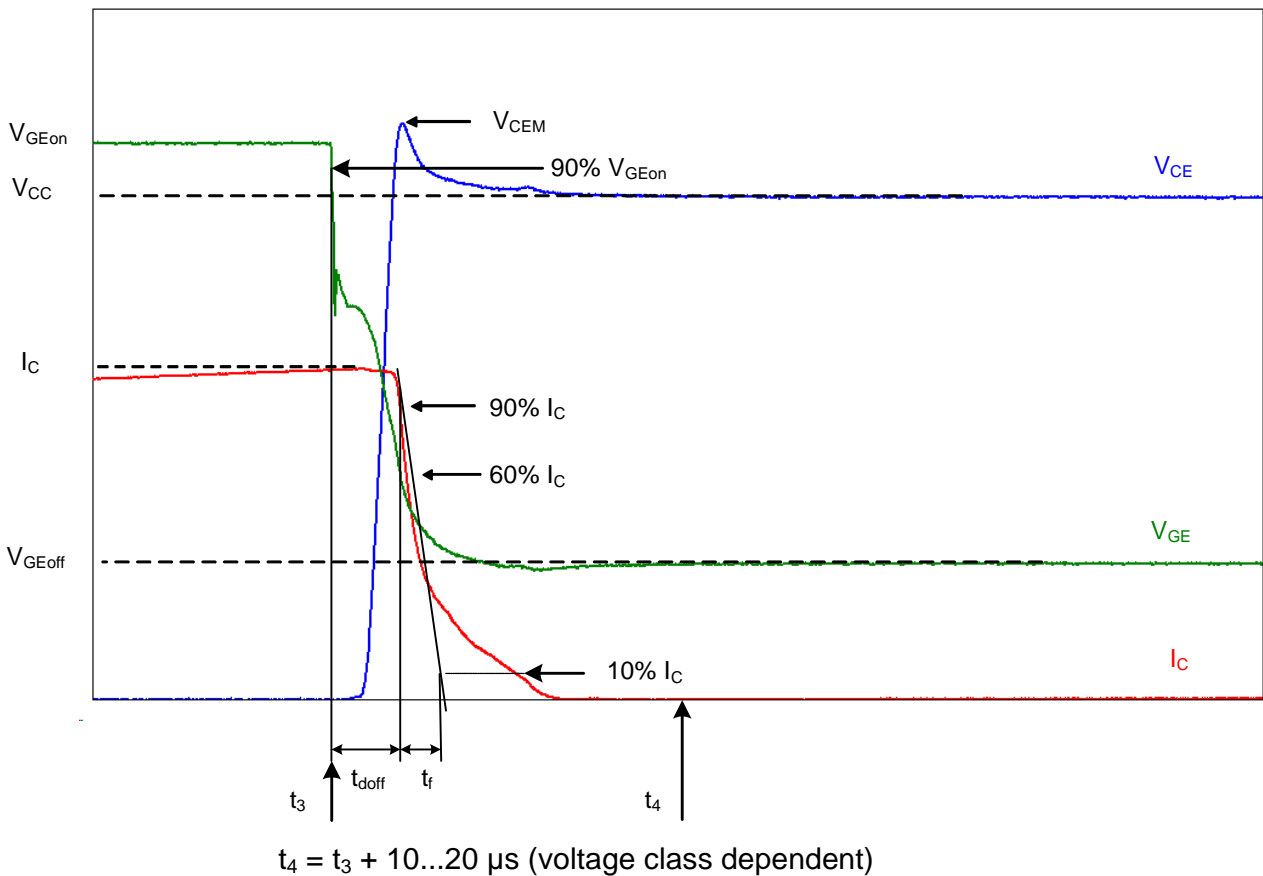

Fig. 4 Definitions of turn-off parameters for IGBTs

**$t_{d(off)}$ :** *Turn-off delay time.* The turn-off delay time is defined as the time between the instant when the gate voltage has dropped to 90 % of its initial value and the instant when the collector current has dropped to 90 % of its initial value.

**$t_f$ :** *Fall time.* The fall time is defined as the time between instants when the collector current has dropped from 90 % to 10 % of its initial value along an extrapolated straight line drawn between the instants when the current has reached 90 % and 60 % of its initial value.

The total turn-off time  $t_{off}$  is the sum of  $t_{d(off)}$  and  $t_f$ .

**$E_{on}$ :** *Turn-on switching energy.* The energy dissipated during a single turn-on event. It is the integration of the product of collector current and collector-emitter voltage from  $t_1$  to  $t_2$  (see Fig. 3) as expressed by Equation 2.

$$E_{on} = \int_{t_1}^{t_2} (i_C(t) \times v_{CE}(t)) dt \quad \text{Equation 2}$$

**$E_{off}$ :** *Turn-off switching energy.* The energy dissipated during a single turn-off event. It is the integration of the product of the collector current and the collector-emitter voltage from  $t_3$  to  $t_4$  (see Fig. 4) as expressed by Equation 3.

$$E_{off} = \int_{t_3}^{t_4} (i_C(t) \times v_{CE}(t)) dt \quad \text{Equation 3}$$

**$I_{sc}$ :** *Short circuit current.* The self-limited current reached in desaturation when the device is turned on into a short circuit at the specified conditions. Typical waveforms during such an event are shown in Fig. 5. The value shown in the data sheet is the average current during the middle 25 % of the current pulse.

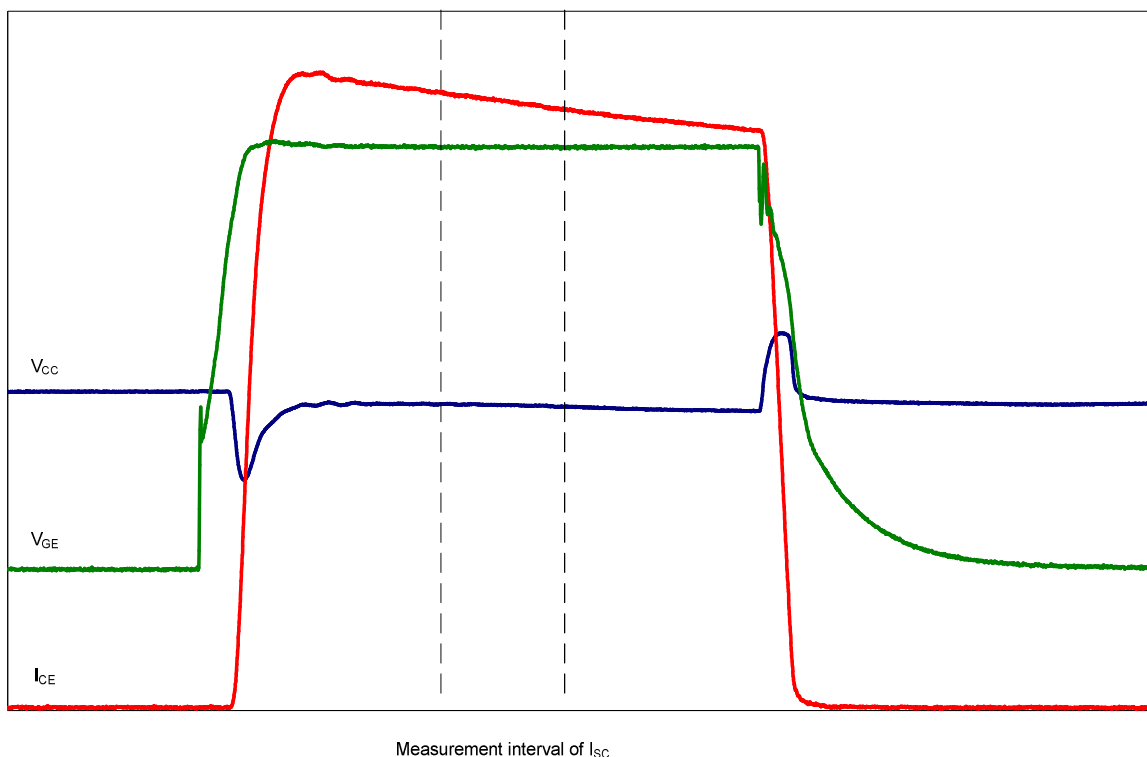

Fig. 5 Typical waveforms for Short-Circuit.

**$L_{\sigma CE}$ :** *Module stray inductance.* The internal inductance of the module measured between the collector and emitter terminals.

$R_{CC'+EE'}$ : Resistance, terminal-to-chip. The internal resistance of the module measured between the collector and emitter terminals excluding the contribution of the chips and the bond wires. At a given current the voltage drop between the collector and emitter terminals can be calculated using Equation 4.

$$V_{CEtotal} = V_{CEsat}(I_C) + R_{CC'+EE'} * I_C \quad E^{qn} 4$$

## 2.4 Diode characteristics

### Diode characteristic values <sup>5)</sup>

Parameter	Symbol	Conditions	min	typ	max	Unit	
Forward voltage <sup>6)</sup>	$V_F$	$I_F = 1200 \text{ A}$	$T_{vj} = 25 \text{ }^\circ\text{C}$	2.0	2.3	2.6	V
			$T_{vj} = 125 \text{ }^\circ\text{C}$	2.0	2.35	2.6	
Reverse recovery current	$I_{rr}$		$T_{vj} = 25 \text{ }^\circ\text{C}$		1100		A
			$T_{vj} = 125 \text{ }^\circ\text{C}$		1350		
Recovered charge	$Q_{rr}$	$V_{CC} = 1800 \text{ V},$ $I_F = 1200 \text{ A},$ $V_{GE} = \pm 15 \text{ V},$ $R_G = 1.5 \text{ } \Omega$ $L_\sigma = 100 \text{ nH}$ inductive load	$T_{vj} = 25 \text{ }^\circ\text{C}$		715		$\mu\text{C}$
			$T_{vj} = 125 \text{ }^\circ\text{C}$		1280		
Reverse recovery time	$t_{rr}$		$T_{vj} = 25 \text{ }^\circ\text{C}$		520		ns
			$T_{vj} = 125 \text{ }^\circ\text{C}$		1450		
Reverse recovery energy	$E_{rec}$		$T_{vj} = 25 \text{ }^\circ\text{C}$		840		mJ
			$T_{vj} = 125 \text{ }^\circ\text{C}$		1530		

<sup>5)</sup> Characteristic values according to IEC 60747 – 2

<sup>6)</sup> Forward voltage is given at chip level

$V_F$ : Forward voltage. The anode-cathode on-state voltage of the diode at the specified conditions. It is given at chip level and includes bond-wire resistance but not terminal resistance which is separately specified.

All switching parameters are defined in a phase leg connection using an auxiliary component of the same type as the device under test (DUT), see Figure 6. For the definitions of the different switching parameters see Figure 7. All switching parameters in the ABB data sheet are specified for inductive load.

Note that other manufacturers may use different definitions for diode turn-off parameters. This must be taken into consideration when comparing modules from different suppliers.

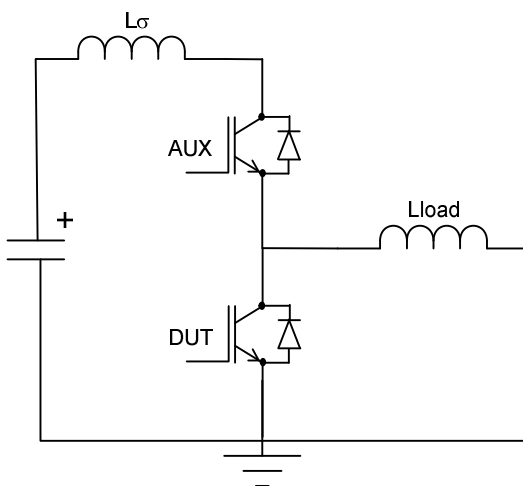

Fig. 6 Test circuit for the dynamic performance of the Diode

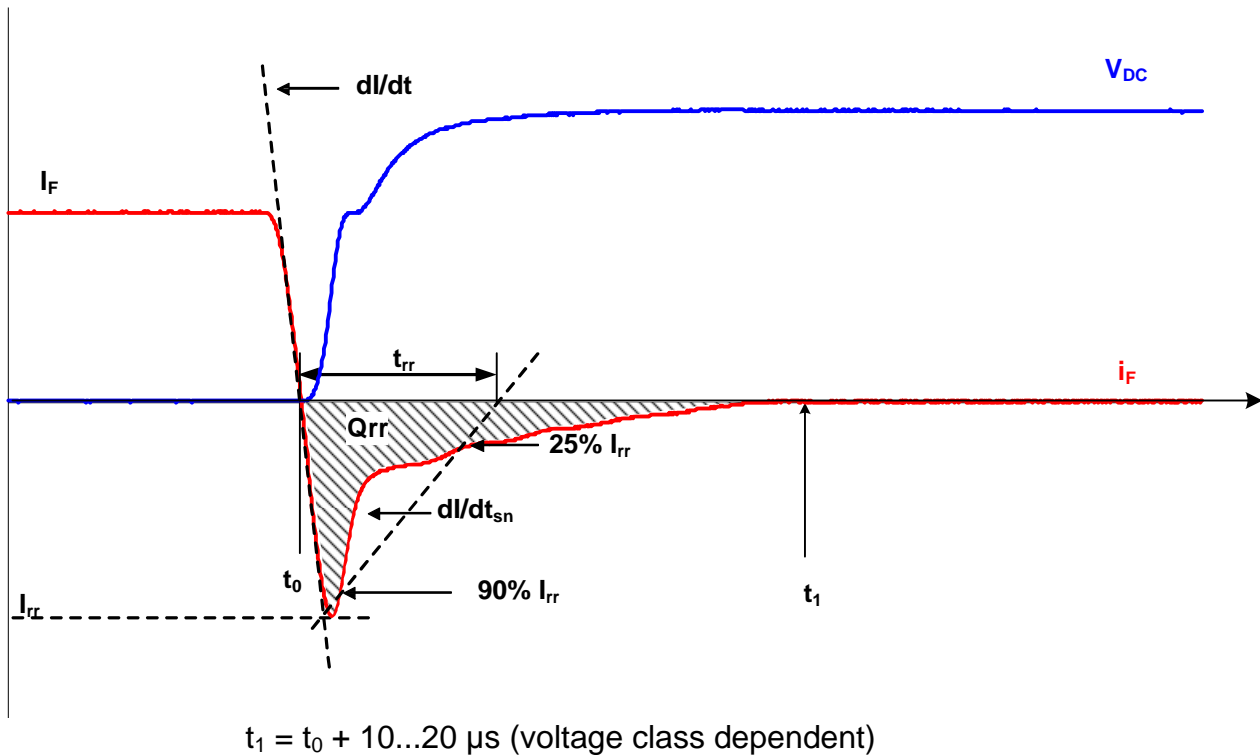

Fig. 7 Definitions for the turn-off parameters for the Diode

$I_{rr}$ : *Reverse recovery current*. The peak value of the reverse current during commutation at the specified conditions.

$Q_{rr}$ : *Reverse recovery charge*. The integral over time of the reverse current during commutation at the specified conditions starting at the zero-crossing of the current and ending when the reverse current has decayed to zero after the tail-current phase.

$t_{rr}$ : *Reverse recovery time*. The commutation time of the diode at the specified conditions. It is measured between the current zero-crossing and the zero-crossing of a straight line drawn between 90% of the reverse current peak on the rising flank and 25 % of peak (on the falling flank).

$E_{rec}$ : *Reverse recovery energy*. The energy dissipated during a single reverse recovery event. It is the integration of the product of the reverse current and voltage from  $t_0$  to  $t_1$  (see Fig. 7) as expressed by Equation 5.

$$E_{rec} = \int_{t_0}^{t_1} (i_R(t) \times v_R(t)) dt \quad E^{qn} 5$$

## 2.5 Thermal properties

Parameter	Symbol	Conditions	min	typ	max	Unit
IGBT thermal resistance junction to case	$R_{th(j-c)IGBT}$				0.0085	K/W
Diode thermal resistance junction to case	$R_{th(j-c)DIODE}$				0.017	K/W
IGBT thermal resistance case to heatsink <sup>2)</sup>	$R_{th(c-s)IGBT}$	IGBT per switch, $\lambda$ grease = 1W/m <sup>2</sup> × K				K/W
Diode thermal resistance case to heatsink <sup>7)</sup>	$R_{th(c-s)DIODE}$	Diode per switch, $\lambda$ grease = 1W/m <sup>2</sup> × K				K/W

<sup>2)</sup> For detailed mounting instructions refer to ABB Document No. 5SYA2039

<sup>7)</sup> Thermal and mechanical properties according to IEC 60747 – 15

**$R_{th(j-c)IGBT}$ :** *IGBT thermal resistance junction to case.* The thermal resistance from the IGBT junction (silicon chip) to the case (base plate). Due to the internal layout there are differences in the thermal resistance between the various IGBT-chips. The value quoted for all IGBT chips together takes this into consideration and allows sufficient margin to ensure that the least-cooled chip does not exceed maximum rated temperature when the *calculated* operating temperature is within the specified limit.

**$R_{th(j-c)DIODE}$ :** *Diode thermal resistance junction to case.* The thermal resistance from the Diode junction (silicon chip) to the case (base plate). Due to the internal layout there are differences in the thermal resistance between the different Diode-chips. The value quoted for all Diode chips together takes this into consideration and allows sufficient margin to ensure that the least-cooled chip does not exceed maximum rated temperature when the calculated operating temperature is within the specified limit.

**$R_{th(c-s)IGBT}$ :** *IGBT thermal resistance case to heat sink.* The thermal resistance from the case (base plate) to the surface of the heat sink for the part of the case that is heated by the IGBT dies. Since this is a dry interface between two surfaces, only one of which is determined by the semiconductor, the quoted value will be met only if the specification for the heat sink surface, the proper type and application of heat transfer grease and the correct mounting procedures, are fulfilled. For details on heat sink properties and correct mounting procedures, see Document 5SYA2039.

**$R_{th(c-s)DIODE}$ :** *Diode thermal resistance case to heat sink.* The thermal resistance from the case (base plate) to the surface of the heat sink for the part of the case that is heated by the Diode dies. Since this is a dry interface between two surfaces, only one of which is determined by semiconductor, the quoted value will be met only if the specification for the heat sink surface, the proper type and application of heat transfer grease and the correct mounting procedures, are fulfilled. For details on heat sink properties and correct mounting procedures, see Document 5SYA2039.

## 2.6 Mechanical properties

Parameter	Symbol	Conditions	min	typ	max	Unit
Dimensions	L × W × H	Typical , see outline drawing	190 × 140 × 38			mm
Clearance distance in air	$d_a$	according to IEC 60664-1 and EN 50124-1	Term. to base:	23		mm
			Term. to term:	19		
Surface creepage distance	$d_s$	according to IEC 60664-1 and EN 50124-1	Term. to base:	33		mm
			Term. to term:	32		
Mass	m			1380		g

<sup>7)</sup> Thermal and mechanical properties according to IEC 60747 – 15

**L \* W \* H:** *Dimensions.* These values are the main dimensions of the device. Details are found in the outline drawing.

---

**d<sub>a</sub>:** *Clearance distance in air.* The air strike distance is defined as the shortest direct path:

- 1) between the terminals and the baseplate
- 2) between terminals.

**d<sub>s</sub>:** *Surface creepage distance.* The surface creepage distance is the shortest path along the plastic housing:

- 1) between the terminals and the baseplate
- 2) between the terminals.

**m:** *Mass.* The weight of the device, excluding packing material.

**CTI:** *Comparative tracking index.* The CTI of a given insulation material gives a comparative value for the resistance of the material towards the creation of conducting tracks on the surface. The CTI is used for insulation coordination when for instance using IEC 60664. The value is determined using the test method given in IEC 60112. The CTI for the devices are available upon request, if not given in the data sheet.

## 2.7 Electrical configuration

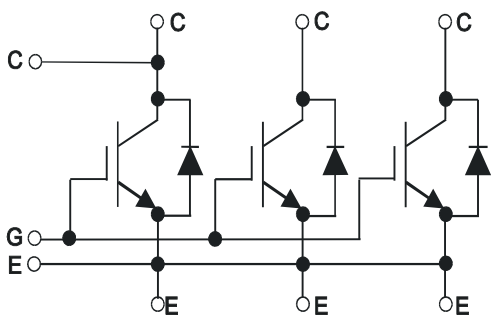

This figure shows the electrical connection of the module and the internal connections between the different terminals.

## 2.8 Outline drawing

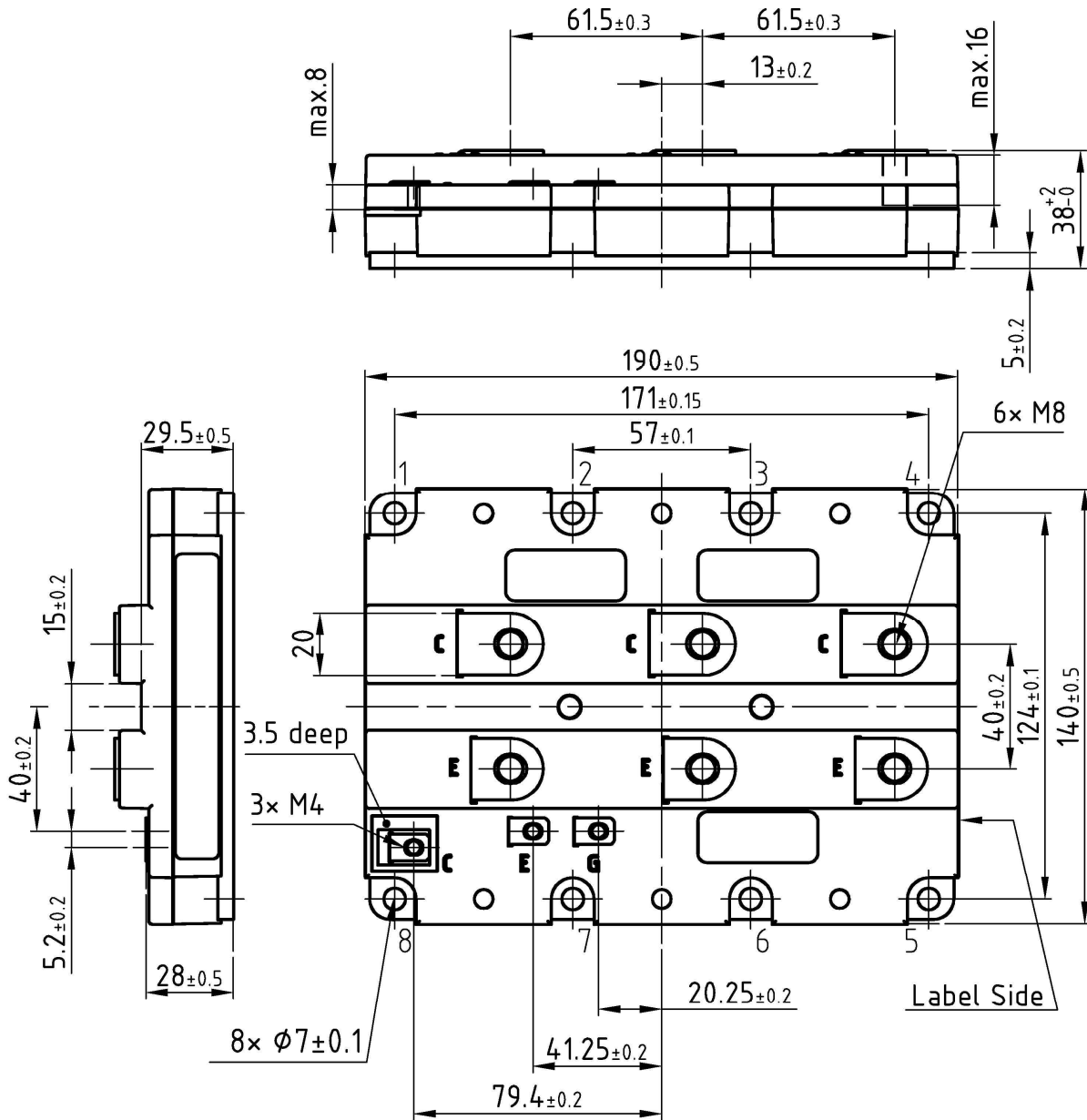

The outline drawing shows the dimensions of the module with the mechanical tolerances. All dimensions for the ABB-products are in mm.

## 2.9 Diagrams

In addition to the table data a number of diagrams are included showing the most important dependencies of the main parameters.

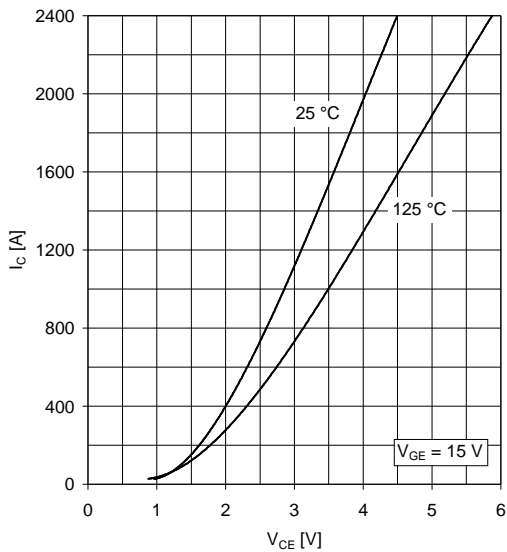

The on-state voltage for the IGBT is given as a function of the collector current at  $V_{GE} = 15\text{ V}$  for junction temperatures 25 and 125 °C. Note that the values are shown at *chip* level which includes the voltage drop in the bond wires but not in the terminals. The values are typical.

Fig. 8 Typical on-state characteristic, chip level

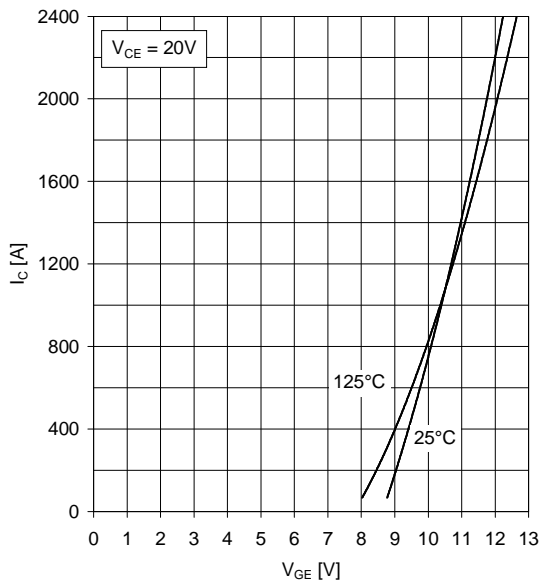

The typical transfer characteristic shows the collector current as a function of the gate-emitter voltage for junction temperatures 25 and 125 °C.

Fig. 9 Typical transfer characteristic, chip level

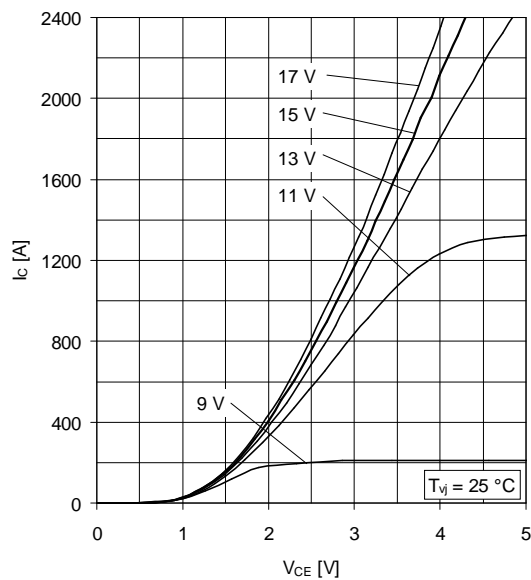

The typical output characteristic shows the collector current as a function of the collector-emitter voltage at gate-emitter voltages of 9, 11, 13, 15 and 17 V for junction temperature 25 °C.

Fig. 10 Typical output characteristic, chip level



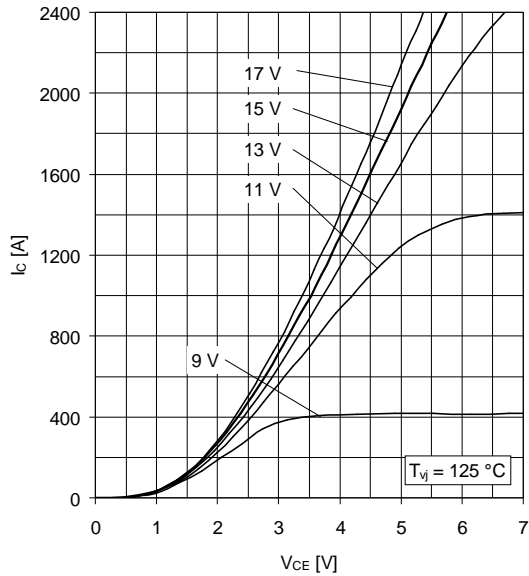

The typical output characteristic shows the collector current as a function of the collector-emitter voltage at gate-emitter voltages of 9, 11, 13, 15 and 17 V for junction temperature 125 °C.

Fig. 11 Typical output characteristic, chip level

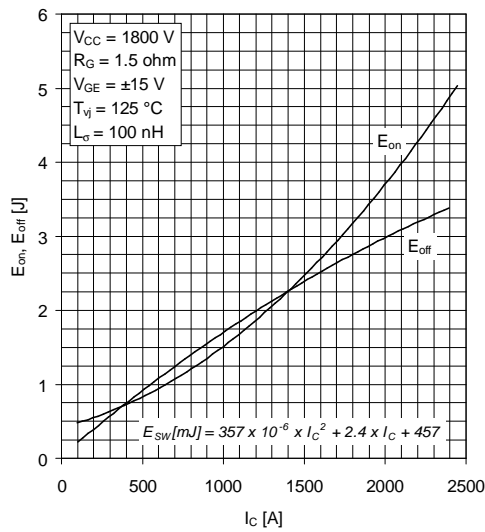

The curves show typical switching energies for the IGBT as a function of the collector current at the specified conditions using the circuit of Fig. 2. Included is a mathematical function for  $E_{sw}$  ( $= E_{on} + E_{off}$ ) as a function of collector current. This function is used in the calculation described in Chapter 3.

Fig. 12 Typical switching energies per pulse vs. collector current

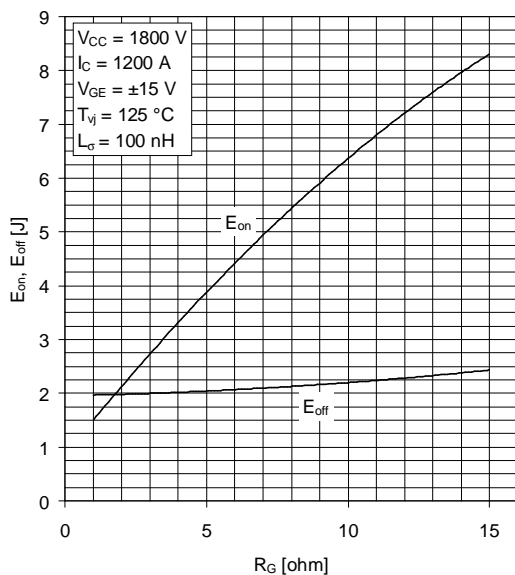

The curves show the typical switching energies for the IGBT as a function of the gate resistor at the given conditions using the circuit in figure 2.

Fig. 13 Typical switching energies per pulse vs. gate resistor

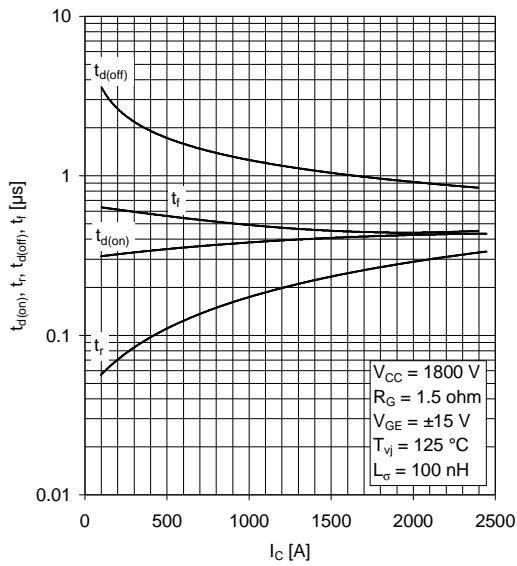

The curves show typical switching times for the IGBT as a function of the collector current at the specified conditions using the circuit of Fig. 2.

Fig. 14 Typical switching times vs. collector current

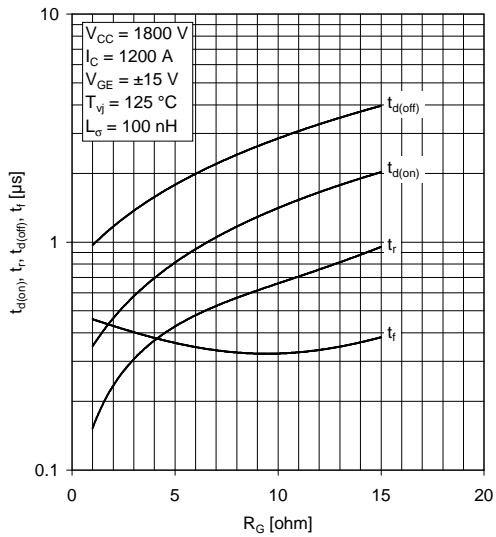

The curves show typical switching times for the IGBT as a function of the gate resistor at the specified conditions using the circuit of Fig. 2.

Fig. 15 Typical switching times vs. gate resistor

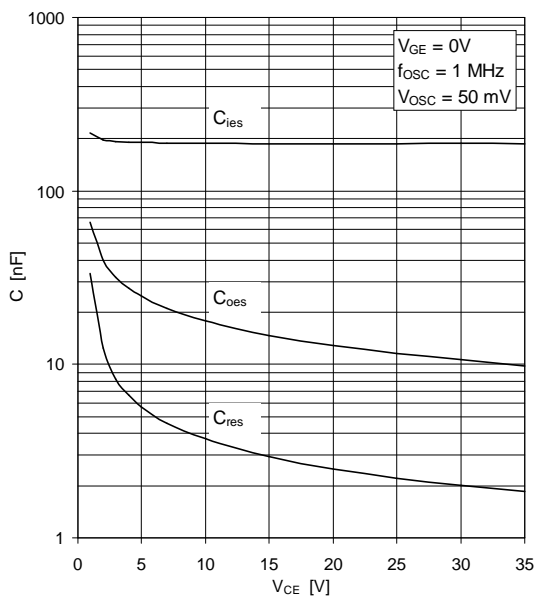

The curves show typical input, output and transfer capacitances as a function of the collector-emitter voltage at the specified conditions.

Fig. 16 Typical capacitances vs collector-emitter voltage

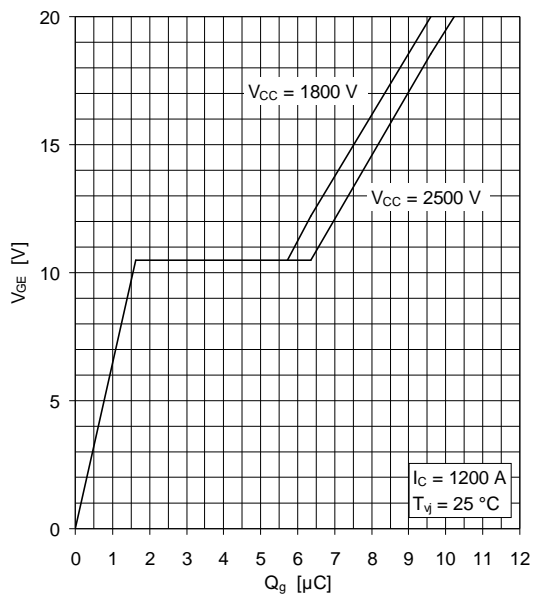

The curve shows the typical gate voltage as a function of the gate charge at collector-emitter voltages 1800 V and 2500 V at the given conditions.

Fig. 17 Typical gate charge characteristics

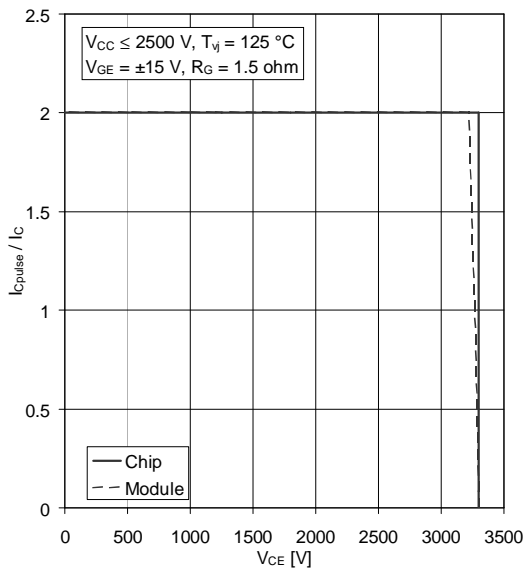

This curve shows the turn-off safe operating area (RBSOA) of the device at the given conditions for chip and module. Since there will always be an inductance in the turn-off circuit, the device cannot be turned off from a voltage equal or close to  $V_{CES}$  since the following criteria for the voltage at turn-off must be fulfilled:

$$V_{CEM} = \left| \frac{di}{dt} \right| \cdot (L_{dCE} + L_s) + V_{CC} \leq V_{CES}$$

Thus,  $V_{CC}$  in the conditions has to be limited to a value well below  $V_{CES}$ .

Fig. 18 Turn-off safe operating area (RBSOA)

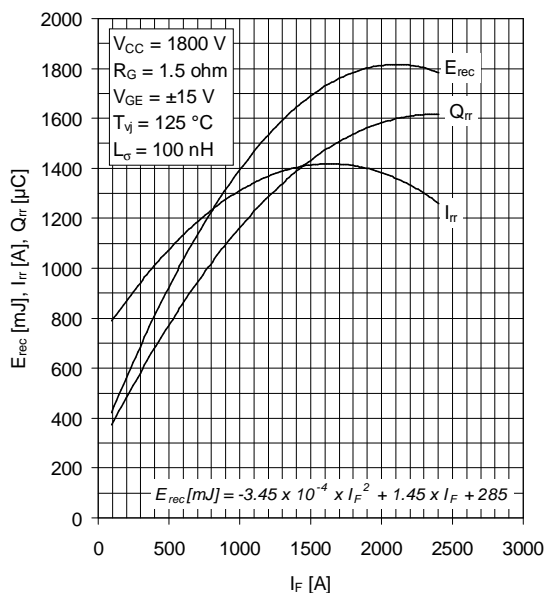

The curves show typical values of turn-off parameters for the diode as a function of the forward current at the specified conditions using the circuit of Fig. 6.

Fig. 19 Typical reverse recovery characteristics vs forward current

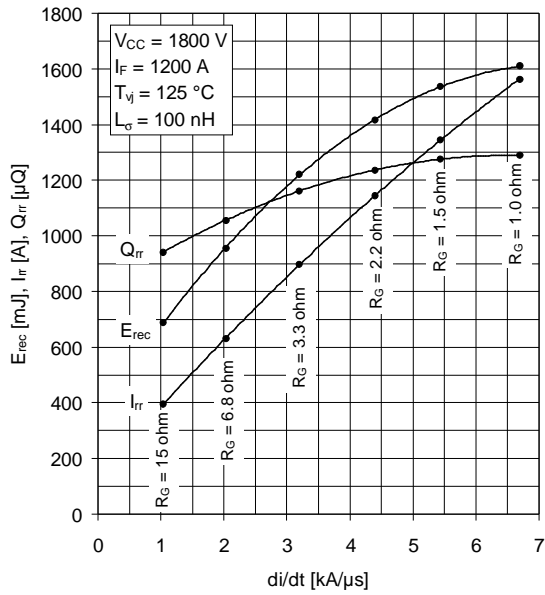

The curves show typical values of turn-off parameters for the diode as a function of the rate of decline of the forward current at the specified conditions using the circuit of Fig. 6. The resistance values indicate the gate resistance for the auxiliary devices giving the corresponding di/dt at the specified conditions.

Fig. 20 Typical reverse recovery characteristics vs di/dt

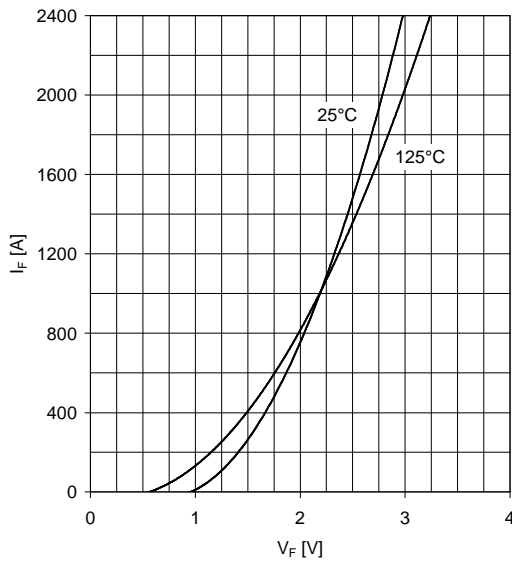

The typical on-state voltage for the Diode is given as a function of the forward current for junction temperatures 25 and 125 °C. Note that the values are shown at chip level which includes the voltage drop in the bond wires but not that in the terminals. The values are typical..

Fig. 21 Typical diode forward characteristic, chip level

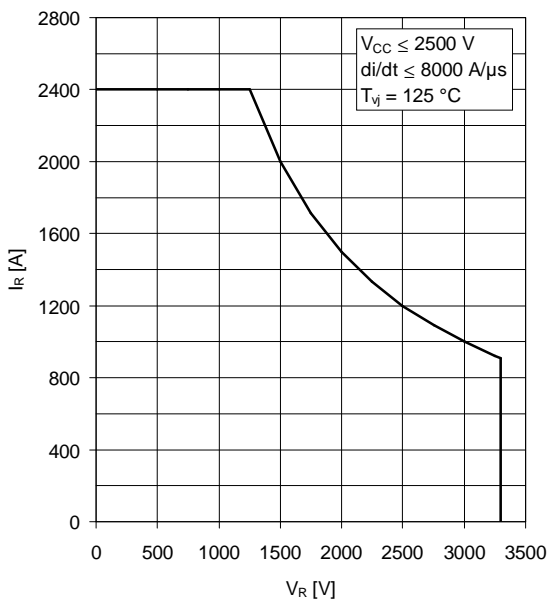

This curve shows the safe operating area (SOA) of the diode at the specified conditions.

Fig. 22 Safe operating area diode (SOA)

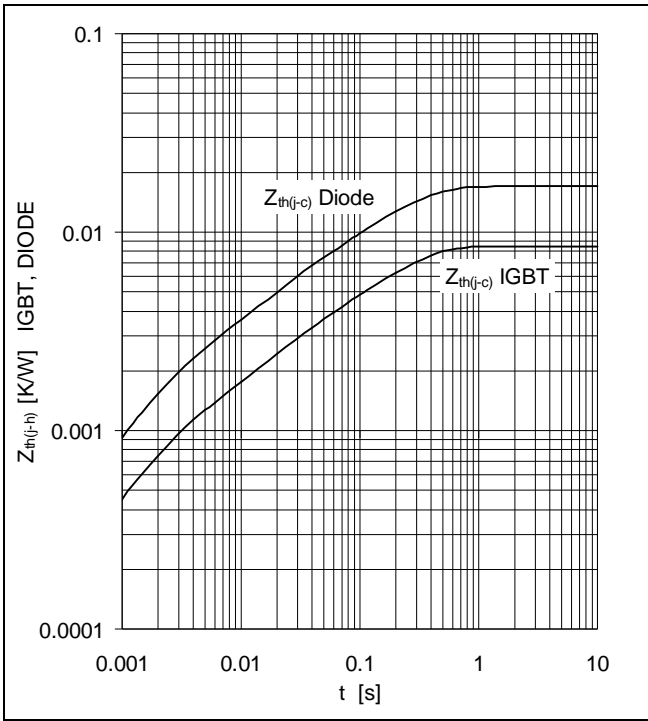

Fig. 23 Thermal impedance vs time

The transient thermal impedance emulates the rise of junction temperature versus time when a constant power is dissipated in the junction. This function can either be specified as a curve or as an analytic function with the superposition of four exponential terms. The analytic expression is particularly useful for computer calculations.

For detailed information please refer to:

- 5SYA 2042-02 Failure rates of HiPak modules due to cosmic rays
- 5SYA 2043-01 Load – cycle capability of HiPaks
- 5SZK 9120-00 Specification of environmental class for HiPak (available upon request)

Fig 24 References.

At the end of the data sheet, a list of applicable documents is included. See Paragraph 4.1 for information on how to obtain these documents

**Analytical function for transient thermal impedance:**

$$Z_{th(j-c)}(t) = \sum_{i=1}^n R_i (1 - e^{-t/\tau_i})$$

	i	1	2	3	4	
IGBT	R <sub>i</sub> (K/kW)	5.854	1.375	0.641	0.632	
	τ <sub>i</sub> (ms)	207.4	30.1	7.55	1.57	
DIODE	R <sub>i</sub> (K/kW)	11.54	2.887	1.229	1.295	
	τ <sub>i</sub> (ms)	203.6	30.1	7.53	1.57	

### 3 Power loss and thermal calculations for the IGBT

To assist customers in calculating power losses and junction temperature for ABB IGBTs under various operating conditions, ABB has developed an Excel-based program which is available at [www.abb.com/semiconductors](http://www.abb.com/semiconductors). This section describes the calculation methods used in this program as well as guidelines for its use.

#### 3.1 Calculation methods

The simulation-tool offers a relatively exact and fast method of loss calculation. The data for the IGBT modules are derived from their corresponding data sheets. The calculations are performed with a linear approximation of the devices' forward characteristics and with a polynomial function for the IGBT and diode switching energies. Additionally, static and switching characteristics are temperature dependent.

The power-dissipation calculation for the IGBTs and diodes is executed by an average computation of the conduction and switching losses over one period  $T_0$  of the output frequency [1]. This approach yields accurate results for two-level voltage source inverters with naturally sampled PWM and sinusoidal output currents.

##### 3.1.1 IGBT loss calculation:

Since the IGBT of one switch conducts only over one half period, the conduction losses are given by the integration of forward losses ( $V_{CE0}$ ,  $r_{CE}$  including  $R_{CC}+R_{EE}$ ) up to  $T_0/2$ :

$$P_{condIGBT} = \frac{1}{T_0} \int_0^{T_0/2} (V_{CE0} \cdot \hat{i} \sin(\omega t) + r_{CE} \cdot (\hat{i} \sin(\omega t))^2) \cdot \tau(t) dt \quad E^{qn} 6$$

with  $\tau(t)$  being a function of the pulse pattern (IGBT turned-on:  $\tau=1$  and IGBT turned-off:  $\tau=0$ ).  $\tau(t)$  can be substituted by a function of modulation ( $m$ ) and phase angle ( $\phi$ ).

With an infinite switching frequency we deduce the duty cycle variation over time (PWM pattern).

$$\tau(t) = \frac{1}{2} (1 + m \sin(\omega t + \phi)) \quad E^{qn} 7$$

Inserting  $\tau(t)$  into the formula and solving the integral we obtain the conduction losses:

$$P_{cond} = \frac{1}{2} (V_{CE0} \cdot \frac{\hat{i}}{p} + r_{CE} \cdot \frac{\hat{i}^2}{4}) + m \cdot \cos \phi \cdot (V_{CE0} \cdot \frac{\hat{i}}{8} + \frac{1}{3p} \cdot r_{CE} \cdot \hat{i}^2) \quad E^{qn} 8$$

The simulation-tool restricts the modulation index to  $m \leq 1$ , which is the linear mode of the PWM.

The switching losses are the sum of all turn-on and turn-off energies.

The measured turn-on and turn-off energies given in the data sheet can be described as a polynomial function ( $E_{sw}=f(I)$ ) (see Fig. 12):

$$E_{sw} = E_{on} + E_{off} = (a + b \cdot I + c \cdot I^2) \quad E^{qn} 9$$

Since the DC-link voltage can vary in different applications, the dependence of the switching energy on the DC-voltage needs to be considered. Within certain limits, this dependence can be assumed to be linear:

[1] D.Srajber, W.Lukasch, "The calculation of the power dissipation for the IGBT and the inverse diode in circuits with sinusoidal output voltage", electronica'92, Proc. pp. 51-58

$$E_{sw} = (a + b \cdot \hat{i} + c \cdot \hat{i}^2) \cdot \frac{V_{DC}}{V_{nom}} \quad E^{qn} 10$$

To calculate the switching losses, the switching energies are summed:

$$P_{sw} = \frac{1}{T_0} \cdot \sum_n E_{sw}(\hat{i}) \quad E^{qn} 11$$

where n depends on the switching frequency.

Therefore we calculate the switching losses as a function of phase-current and switching frequency:

$$P_{sw} = f_{sw} \cdot \left( \frac{a}{2} + \frac{b \cdot \hat{i}}{p} + \frac{c \cdot \hat{i}^2}{4} \right) \cdot \frac{V_{DC}}{V_{nom}} \quad E^{qn} 12$$

The total IGBT losses are the sum of the conduction and switching losses:

$$P_{IGBT} = P_{cond} + P_{sw} \quad E^{qn} 13$$

### 3.1.2 Diode loss calculation:

The diode losses are calculated in almost the same way as those of the IGBT. Since the freewheeling diode conducts when the IGBT is turned-off, the function of the pulse pattern has to be negated:

$$P_{cond} = \frac{1}{2} \left( V_{F0} \cdot \frac{\hat{i}}{p} + r_T \cdot \frac{\hat{i}^2}{4} \right) - m \cdot \cos f \cdot \left( V_{T0} \cdot \frac{\hat{i}}{8} + \frac{1}{3p} \cdot r_T \cdot \hat{i}^2 \right) \quad E^{qn} 14$$

In the case of the diode, the turn-on energy can be disregarded and only the recovery energy counts. The recovery energy given in the data sheet diagram can be described as a polynomial function:

$$E_{rec} = (a + b \cdot I + c \cdot I^2) \quad E^{qn} 15$$

The recovery losses as a function of phase-current and switching frequency and  $V_{DC}$  can be written as:

$$P_{rec} = f_{sw} \cdot \left( \frac{a}{2} + \frac{b \cdot \hat{i}}{p} + \frac{c \cdot \hat{i}^2}{4} \right) \cdot \frac{V_{DC}}{V_{nom}} \quad E^{qn} 16$$

The total diode losses are the sum of the conduction and switching losses:

$$P_{Diode} = P_{cond} + P_{sw} \quad E^{qn} 17$$

### 3.1.3 Thermal Calculation:

The loss calculation yields average losses over one output cycle. In fact the losses per switch only occur during one half-period and during the alternate half period, it is the complementary switch which produces losses.

Fig. 25 shows, in the upper graph, a PWM chopped current as it appears in the case of a two level VSI. In addition, the resulting junction temperature is shown (as calculated by convolution of instantaneous power loss and thermal impedance). It is obvious that the junction temperature oscillates with the frequency of the output current. In the lower graph the corresponding losses  $P_{smoothed}$  are shown. As a comparison, the calculated average losses ( $P_{av}$ ) from the simulation-tool are shown (dashed line).

If the junction temperature is calculated with  $T_j = P_{smoothed} \cdot R_{th}$ ; evidently the peak value of junction temperature exceeds the result of  $T_j$  calculated with the average losses  $P_{av}$ . Therefore the calculation of  $T_j$  with average losses yields an optimistic value.

In order to minimise this inaccuracy, the simulation-tool calculates with  $P_{mod}$  which is twice the average losses ( $P_{av}$ ) dissipated during one half period of the phase current. The resulting junction temperature  $T_{jmod}$  is shown in the lower graph of Fig. 25 and matches well in terms of the peak and bottom values with the real value of  $T_j$ . Nevertheless, at output frequencies below 5 Hz the results of the simplification start to diverge significantly from reality.

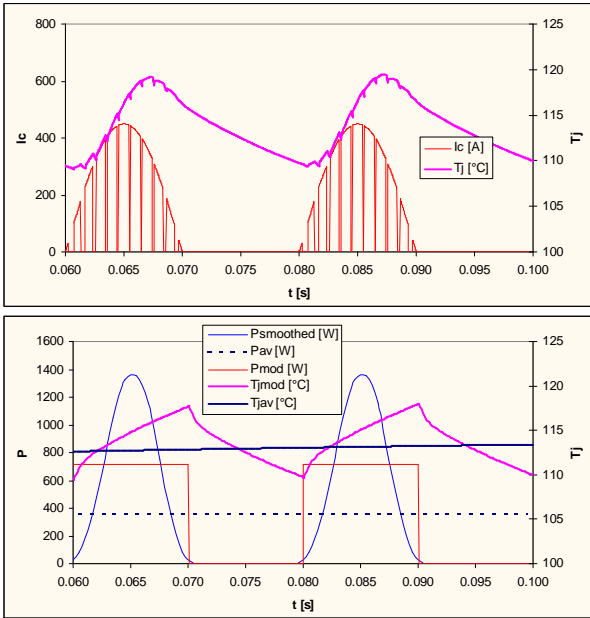

Fig. 25: Junction temperature as a function of  $f_o$

The maximum junction temperature  $T_{vj \max}$ , as a function of the phase output-current frequency  $f_o$ , can be calculated if the transient thermal resistance is known:

$$T_{vj \max} = 2 \cdot P_{AV} \cdot \sum_{i=1}^n R_i \frac{1 - e^{-\frac{1}{2 \cdot f_o \cdot t_i}}}{1 - e^{-\frac{1}{f_o \cdot t_i}}} + T_{ref} \quad E^{qn} 18$$

with  $T_{ref}$  as the reference heat sink temperature,  $T_h$  for base-less modules or case temperature  $T_c$  for based modules.

### 3.1.4 Calculations with a Heat sink:

The simulation-tool uses a simplified approach to calculate temperature rises and cross-talk effects. This has the advantage that the calculations can be performed using module and heat sink data sheet values.

More accurate methods based on finite element calculations require specific knowledge about module and cooler construction and need much more time for parameter extraction as well as for the calculations. On the other hand, the simplified method of the simulation-tool allows quick and accurate simulation without detailed knowledge of cooler and module construction.



The simplification in the simulation-tool lies in the assumption of a common reference temperature point, where the temperature is assumed to be homogenous over the full area. This reference is the heat sink temperature (Fig. 26):

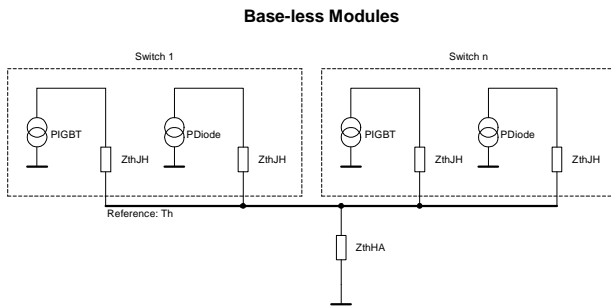

Fig. 26 Thermal equivalent block diagram for baseless devices.

The static calculation of the temperature rise in the heat sink can be calculated with the thermal resistance of the cooler and the number of dissipating heat sources mounted on it:

$$T_H = T_A + (P_{IGBT} + P_{Diode}) \cdot n_S \cdot R_{thHA} \quad E^{qn} 19$$

with  $n_S$  as the number of switches mounted on the cooler.

For devices with a base-plate, the reference is also the case temperature. The thermal characteristic of a device with a base-plate is normally specified with  $Z_{thJC}$  (thermal impedance junction – case) for the IGBT and diode parts. Additionally, the interface resistance case to heat sink ( $R_{thCS}$ ) is given separately for each IGBT and diode. Fig. 27 shows the thermal equivalent block diagram for modules with a base-plate:

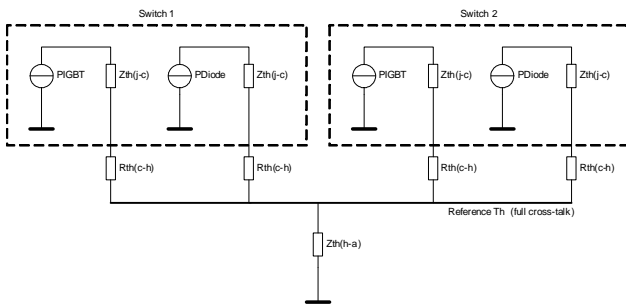

Fig. 27 Thermal equivalent block diagram for devices with baseplate.

As in the case of baseless modules, the static calculation of the temperature rise in the heat sink can be calculated with the thermal resistance of the cooler and the number of dissipating heat sources mounted on it:

$$T_H = T_A + (P_{IGBT} + P_{Diode}) \cdot n_S \cdot R_{thHA} \quad E^{qn} 20$$

Additionally the temperature rise in the interface  $\Delta T_{CH}$  needs to be calculated. Since more than one module may be mounted on the heat sink and the heat sources may be distributed in several modules (e.g. in a three-phase inverter built with three halve-bridge modules mounted on a single cooler) it becomes necessary to scale the interface resistance accordingly:

$$\Delta T_{CH} = P_{IGBT / Diode} \cdot R_{thCH} \quad E^{qn} 21$$

In order to calculate the temperature-dependent semiconductor losses, the simulation-tool adjusts the junction temperature and the corresponding losses in several iterations. Depending on the module type and the calculation (with/without heat sink), the calculation starts with the initial conditions  $T_{vj} = T_A$ ,  $T_{vj} = T_H$  or  $T_{vj} = T_C$ .

### 3.1.5 Transient Overload Calculation:

The simulation-tool offers the possibility to additionally calculate the transient thermal behaviour of the IGBT module and the heat sink.

The transient temperature rise can be calculated with the thermal impedance.

$$Z_{th}(t) = \sum_{i=1}^n R_i \cdot (1 - e^{-t/t_i}) \quad E^{qn} 22$$

The temperature rise  $\Delta T(t)$  is a function of  $Z_{th}(t)$  and the temperature-dependent power dissipation in the semiconductor  $P(T)$ .

$$\Delta T(t) = -\frac{\Delta T_{start}}{R_{th}} \cdot Z_{th}(t) + P(T) \cdot Z_{th}(t) \quad E^{qn} 23$$

In order to include the starting conditions for  $\Delta T$ , the first term is introduced.  $\Delta T_{start} / R_{th}$  describes the initial constant power that resulted in  $\Delta T_{start}$ . This deposited power influences the thermal behaviour until  $Z_{th}(t) = R_{th}(t)$ .

The second term describes the heating with the temperature-dependant power  $P(T)$ . Since  $T$  is as well a function of the dissipated power and the thermal impedance, iterations are necessary to obtain an accurate result.

For the transient heat sink temperature we can write:

$$T_H(t) = T_A - \frac{T_{Hstart} - T_A}{R_{thHA}} \cdot Z_{thHA}(t) + P(T) \cdot Z_{thHA}(t) \quad E^{qn} 24$$

where  $P(T)$  depends on the number of switches mounted on the heat sink.

$$P(T) = (P_{IGBT}(T) + P_{Diode}(T)) \cdot n_s \quad E^{qn} 25$$

For the transient average junction temperature we can write:

$$T_{vjav}(t) = T_H(t) - \frac{T_{vjstart} - T_{Hstart}}{R_{thJH}} \cdot Z_{thJH}(t) + P(T) \cdot Z_{thJH}(t) \quad E^{qn} 26$$

In the case of modules with a base plate,  $T_H$  has to be replaced with  $T_C$  and  $R_{thJH}$  and  $Z_{thJH}$  have to be replaced with  $R_{thJC}$  and  $Z_{thJC}$  respectively. In addition, the temperature drop across the interface  $\Delta T_{CH}$  has to be calculated. Since the interface has no heat capacity, this can be done in a similar manner to the static calculations ( $E^{qn} 21$ ).

Thus we are able to calculate the transient average junction temperature. As already mentioned, the average junction temperature yields overly optimistic values. The temperature ripple as a function of the output current needs to be considered.

To avoid too high a complexity, the simulation-tool uses a simplified approach that is valid in most application cases.

The approach is to calculate the "overshoot temperature" ( $T_{ov}$ ) due to the output frequency ripple at the end of the overload pulse and add it to the calculated average temperature:

$$T_{vjmax}(t) = T_{vjav}(t) + T_{ov} \quad E^{qn} 27$$

$$T_{ov} = \left( 2 \cdot P(T) \cdot \sum_{i=1}^n R_i \frac{1 - e^{-\frac{1}{2f_o t_i}}}{1 - e^{-\frac{1}{f_o t_i}}} + T_{ref} \right) - P(T) \cdot R_{th} \quad E^{qn} 28$$

This is valid as long as the  $Z_{th}(t)$  of the module is close to its  $R_{th}$  value. For most modules, this is the case between 0.5 and 1s. Below this time span, the values for  $T_{vj\ max}(t)$  are slightly optimistic. Thus the simulation-tool does not allow transient calculations for durations shorter than 1s.

### 3.2 Using the ABB simulation tool

The simulation-tool calculates losses and temperatures for turn-off devices (e.g. IGBTs) and free-wheeling diodes in a PWM 2-level voltage-source inverter (Fig. 1). The results are calculated for one switch. As pointed out in the previous section, the calculation is based on a sinusoidal output current. For other topologies such as 3-level and other control methods, as for instance vector control, direct control etc. the results may no longer be representative. In these cases, it is the user's sole responsibility to verify whether deviations from the assumptions are still allowable.

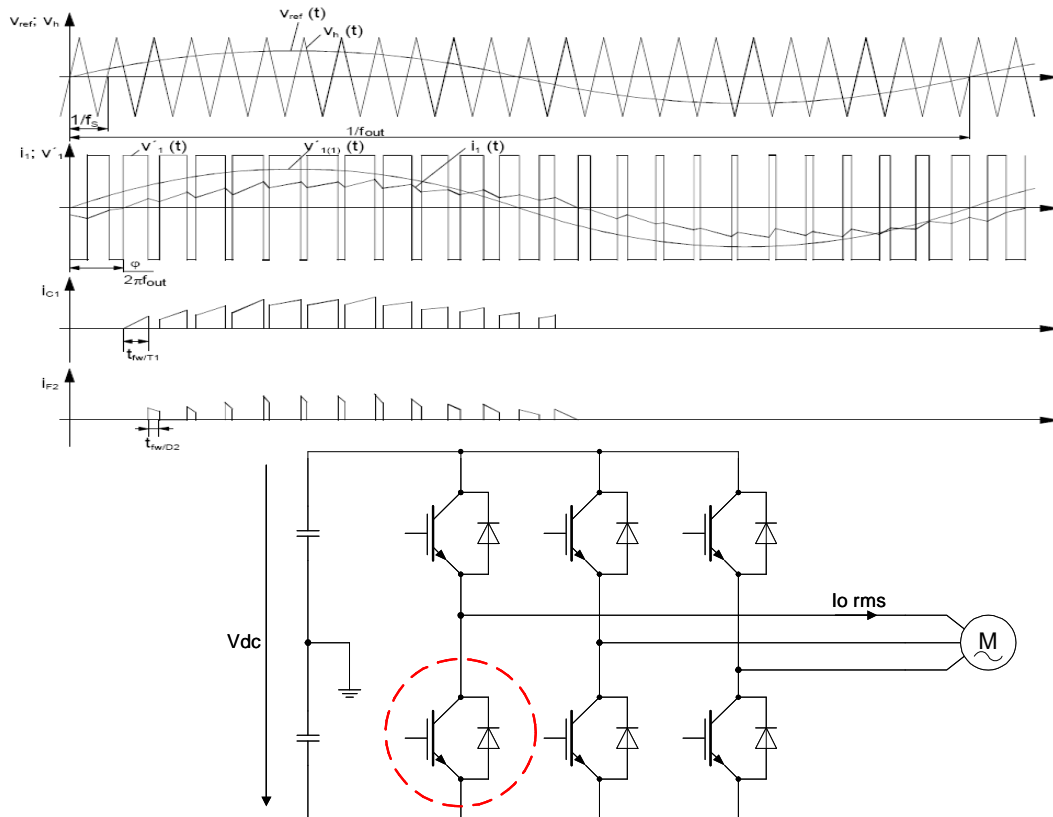

Fig. 28 Definitions, topology and modulation used in the ABB simulation tool.

#### 3.2.1 Program parts

The simulation tool has actually four program parts:

- Output  
simple calculation with fixed case-temperature.
- Heat sink & Transient  
Calculation including heat-sink parameters and simulation of transient temperature rises.  
Calculating heat-flow from main contacts to the bus-bar.
- Performance Chart  
Computes the output-current versus switching frequency that can be achieved for a certain module type at given conditions.
- Load Profile  
Transient simulation of temperatures and losses for a given load profile.

#### Output:

The output program part can compute the junction temperature for given conditions and a fixed case/heat-sink temperature. With the button "Solve", the output current for a given junction temperature  $T_{vj}$  can also be calculated (Fig. 30).

The device model can be selected with the drop-down menu in the upper center of the sheet. The required input parameters include: Output Current, DC- Link Voltage, Output Frequency, Switching Frequency, Modulation Index and Load Power Factor. The parameters have to be entered into the yellow shaded fields and are confirmed in the cyan coloured fields provided they are within the necessary boundaries; this is common to all parts of the program. Inverter developers might be troubled by the absence of output voltage as an input parameter for the loss calculations. This is because it is the Modulation Index which determines the output voltage (and losses). Nevertheless the output voltage can be calculated for PWM (Fig. 29).

### Modulation Index

**n** Phase to phase voltage  
(H-bridge, 3-phase inverter)

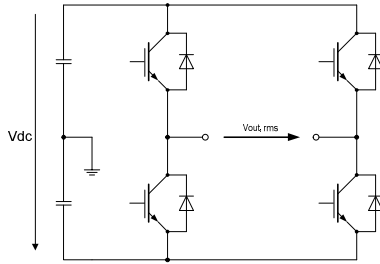

$$V_{out,rms} = \frac{V_{DC}}{\sqrt{2}} \cdot m$$

$$m = \frac{V_{out,rms} \cdot \sqrt{2}}{V_{DC}}$$

**n** Phase to ground

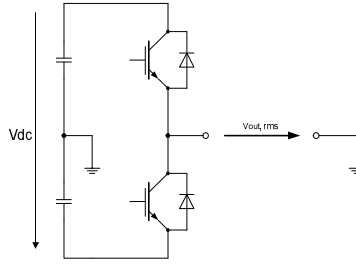

$$V_{out,rms} = \frac{V_{DC}}{2 \cdot \sqrt{2}} \cdot m$$

$$m = \frac{2 \cdot V_{out,rms} \cdot \sqrt{2}}{V_{DC}}$$

Fig. 29: Calculation of the output voltage at different connections.

The calculated results for one switch are shown in the section “Calculated Results”. Additionally the program offers two diagrams for the losses and temperatures as a function of output current for one switch (Fig. 31).

### Output

Define load of the inverter,  
DC voltage and modulation

Confirmed values  
within boundaries

Solver

Simulation Tool for ABB IGBTs			V 6.00, Oct. 2005
Select Device:		5SNA 1200E330100	HiPak 140°190mm, SPT, 1200A, 3300V
<b>Enter application parameters:</b>			
	<i>input</i>	<i>limits</i>	<i>used values</i>
Output current Io rms [A]:	1000	$I_o < 2 \times I_{cn}/\sqrt{2} = 1697A$	1000
DC link voltage Vdc [V]:	1800	$1080V < V_{dc} < 2520V$	1800
Output frequency f0 [Hz]:	50	$1Hz < f_0 < 1000Hz$	50
Switching frequency fsw [Hz]:	1000	$5 \times f_0 < f_{sw} < 30000Hz$	1000
Modulation index m:	1.00	$0 < m < 1$	1.00
Load power factor cosφ:	0.85	$-1 < \cos\phi < 1$	0.85
Tc [°C]:	90	$5^\circ C < T_c < 125$	90
Junction temperature Tvj [°C]: (only for diagrams and solver)	125	$5^\circ C < T_{vj} < 150^\circ C$	125
		Gate resistor RG [Ohm]:	1.5
<b>Solve for Io max</b>			
<b>Calculated results</b>			
<b>io max [A]:</b>		<b>1158.3</b>	
Losses per IGBT & Diode [W]:		4411.9	
IGBT total losses [W]:		3545.7	
Tvj max IGBT [°C]:		125	
Diode total losses [W]:		866.2	
Tvj max Diode [°C]:		107	
<b>Calculated Results:</b>			
<b>Total switch losses(IGBT&amp;Diode) [W]:</b>		<b>3606.9</b>	
<b>Tvj max [°C]:</b>		<b>118</b>	
<b>IGBT:</b>		<b>Diode:</b>	
IGBT total losses [W]:	2882.9	Diode total losses [W]:	723.9
IGBT conduction losses [W]:	1422.9	Diode conduction losses [W]:	159.4
IGBT switching losses [W]:	1460.0	Diode switching losses [W]:	564.5
Tvj max [°C]:	118	Tvj max [°C]:	104
Ripple ΔTvj [°C]:	7.9	Ripple ΔTvj [°C]:	4.0

Calculated Results

Fig. 30 The output sheet.

## Output Diagrams

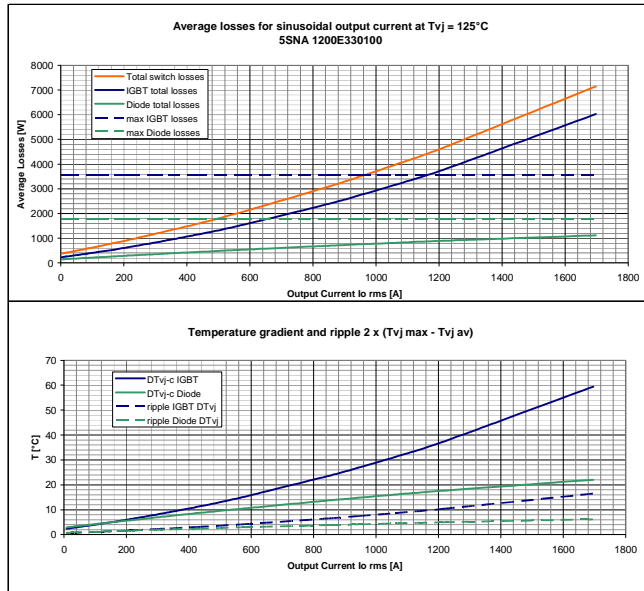

Fig. 31: Curves of losses and temperatures vs. output current

### Heat sink & Transient:

This part of the program requires identical parameters and works similarly to the Output part (Fig. 32). The main difference is that the heat-sink thermal impedance is included in the calculation. Therefore, a heat sink needs to be selected. If necessary the heat-sink thermal impedance can be adjusted with a multiplier. This might be useful in cases where the area for which R<sub>th</sub> is defined does not correspond to the module footprint. It is equally important that the number of operational switches mounted on the same heat sink be entered. For example, in the case of a dual module, n = 2.

In addition the heat-flow from the main terminals to the bus-bar ( $P_{(T-B)}$ ) can be calculated and a warning message appears if the current in the main terminals leads to an overheating of the internal contacts (e.g. rms current in main terminals higher than recommended).

The heat-flow from the terminals to the bus-bar depends on the temperature of the external terminal contact. By default this temperature is set to 105 °C (usual temperature limit of bus-bars). Certainly this temperature strongly depends on the bus-bar design parameters such as cross-section (self-heating), bus-bar cooling and ambient temperature.

It is thus strongly recommended to verify this assumption with measurements.

In order to enable the tool to calculate the heat-flow and identify too high terminal current, detailed models of the electrical and thermal terminal properties need to be available. This data are stored in the tool library for all HiPak modules.

# Heatsink & Transient

Simulation Tool for ABB IGBTs V 6.24, Jan. 2009

**Heatsink and Transient Calculations**

Select Heatsink: 9.5K/KW, water-cooled, HiPak2 Rth-Multiplier: 1.0 water cooled, for HiPak2

Selected Device: 5SNA 1500E330300 SPT+ HiPak 140\*190mm, SPT+, 1500A, 3300V

Enter application parameters:				Heatsink Characteristics	
	input	limits	used values	Rth [K/W]	ath [s]
Output current I <sub>o rms</sub> [A]:	1000	$I_o < 2 \times I_{cn}/\sqrt{2} = 2121A$	1000	9.50E-03	4.50E+01
DC link voltage V <sub>dc</sub> [V]:	1800	1080V < V <sub>dc</sub> < 2520V	1800		1.00E+00
Output frequency f <sub>0</sub> [Hz]:	50	1Hz < f <sub>0</sub> < 1000Hz	50		1.00E+00
Switching frequency f <sub>sw</sub> [Hz]:	1000	$5 \times f_0 < f_{sw} < 30000Hz$	1000		1.00E+00
Modulation index m:	1.00	0 < m < 1	1.00		1.00E+00
Load power factor cosφ	0.85	-1 < cosφ < 1	0.85		
<b>Enter ambient temperature and configuration of devices</b>				<b>RthHA [KW] 0.010</b>	
TA [°C]	40	0°C < TA < 100°C	40		
Number of switches on heatsink	1	1 < ns	1		
Temperature of main terminals [°C]	105	40°C < T <sub>TH</sub> < 150°C	105		

Calculated Results: (losses per switch)	
<b>Total switch losses (IGBT&amp;Diode) [W]:</b>	<b>3209.0</b> / <b>Tvj max [°C]: 116</b>
<b>Heatflow terminals to bus-bar P<sub>TR-AB</sub> [W]:</b>	<b>10.0</b>

IGBT:		Diode:	
IGBT total losses [W]:	2476.4	Diode total losses [W]:	772.6
IGBT conduction losses [W]:	1100.2	Diode conduction losses [W]:	135.6
IGBT switching losses [W]:	1436.3	Diode switching losses [W]:	637.0
Tvj max [°C]:	116	Tvj max [°C]:	100
Ripple / Tvj [°C]:	6.7	Ripple / Tvj [°C]:	4.3
Th [°C]	70.5		
Tc [°C]	92.4	Tc [°C]	84.4

important

Fig. 32 View of the heat sink & transient calculations sheet.

For transient overload studies, the temperatures prior to overload and the overload duration need to be specified (Fig. 33).

## Heatsink & Transient / Overload\*

n Additional Inputs for the overload calculation:

- n Temperatures prior to overload
- n Overload duration

Transient Overload Calculations			
<b>Enter overload conditions:</b>			
Output current I <sub>o rms</sub> [A]:	1200	$I_o < 2 \times I_{cn}/\sqrt{2} = 1697A$	1200
DC link voltage V <sub>dc</sub> [V]:	1800	1080V < V <sub>dc</sub> < 2520V	1800
Output frequency f <sub>0</sub> [Hz]:	25	1Hz < f <sub>0</sub> < 1000Hz	25
Switching frequency f <sub>sw</sub> [Hz]:	1000	$5 \times f_0 < f_{sw} < 30000Hz$	1000
Modulation index m:	0.50	0 < m < 1	0.50
Load power factor cosφ:	0.50	-1 < cosφ < 1	0.50
Tj start IGBT [°C]*	50	50 < Tj start IGBT [°C]* < 150	50
Tj start Diode [°C]*	50	50 < Tj start Diode [°C]* < 150	50
Th start*	50	40 < Tc [°C] < 50	50
Overload duration [s]	30	1 < t [s] < 1000	30
* as default values select results from heatsink calculation results			
<b>Calculated Results after overload t =30 s</b>			TA [°C] 40
<b>Total switch losses(IGBT&amp;Diode) [W]:</b>		<b>4270.7</b>	<b>Tvj max [°C]: 125</b>
<b>IGBT:</b>		<b>Diode:</b>	
IGBT total losses [W]:	3101.2	Diode total losses [W]:	1169.5
IGBT conduction losses [W]:	1352.0	Diode conduction losses [W]:	552.9
IGBT switching losses [W]:	1749.3	Diode switching losses [W]:	616.6
Tvj max [°C]:	125	Tvj max [°C]:	110
Th [°C]	64.9		
Tc [°C]	92.8	Tc [°C]	85.9

\*Load relaxation can be computed as well

Fig. 33 The input fields for the overload calculation.

## Heatsink & Transient / Overload Diagram

- n The various temperatures during the overload are shown in the diagram.

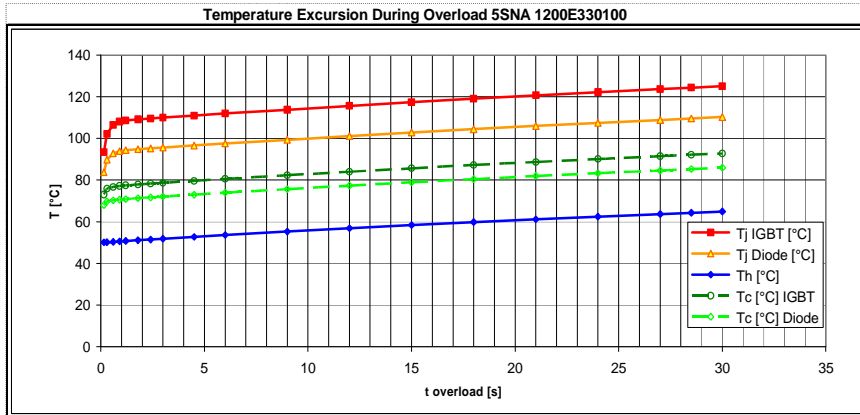

Fig. 34 Output curves showing temperature excursion during the defined overload.

### Performance chart:

This part of the program computes the inverter output current as a function of the switching frequency (Figs. 35 and 36).

The switching frequency range of interest can be specified. For easy comparison, up to three modules can be displayed in one chart. The results can be copied into the corresponding columns by pressing the button “Copy Results”:

## Performance chart

Simulation Tool for ABB IGBTs V6.1, Jan. 2007

Select Heatsink: 9.5K/8W, water-cooled, HIPak2 Performance Chart Rth-Multiplier 1.0 water cooled, for 1 HIPak2

Selected Device: 5SNA 1200E330100 HIPak 140\*190mm, SPT, 1200A, 3300V

Enter application parameters:

	input	limits	used values
DC link voltage Vdc [V]: <sup>1</sup>	1800	1080V < Vdc < 2520V	1800
Output frequency f [Hz]	50	1Hz < f < 1000Hz	50
Min. Switching frequency fsw [Hz]	250	5 x f < fsw < 30000Hz	250
Max. Switching frequency fsw [Hz]	2000	5 x f < fsw < 30000Hz	2000
Modulation index m <sup>2</sup>	1.00	0 < m < 1	1.00
Load power factor cosφ	0.85	-1 < cosφ < 1	0.85

Heatsink Characteristics

Rth [K/W]	αth [s]
9.50E-03	4.50E+01
0.00E+00	1.00E+00
0.00E+00	1.00E+00
0.00E+00	1.00E+00
<b>RthHA [K/W]</b>	<b>0.010</b>

Enter ambient temperature and configuration of devices

TA [°C]	0°C < TA < 100°C
40	40
Number of switches on heatsink	1
maximum junction temperature Tj [°C]	125

Solve

f [Hz]	results 5SNA 1200E330100	copy results 5SNA 1200G330100	copy results 5SNA 1500E330300
250.0	1363.7	1354.2	1655.2
304.7	1318.5	1319.7	1606.7
414.1	1251.3	1254.0	1514.5
523.4	1188.3	1192.3	1428.4
742.2	1073.5	1079.6	1274.3
960.9	972.2		1141.3
1398.4	803.6	810.2	928.8
2000.0	628.1	630.2	700.1

Start calculation (points to Solve button)

Calculated Results (points to results table)

copy results (points to copy buttons)

Fig. 35 The calculation sheet for the performance chart.

## Performance chart

- If comparing the modules with “copy results” make sure the conditions remain identical!

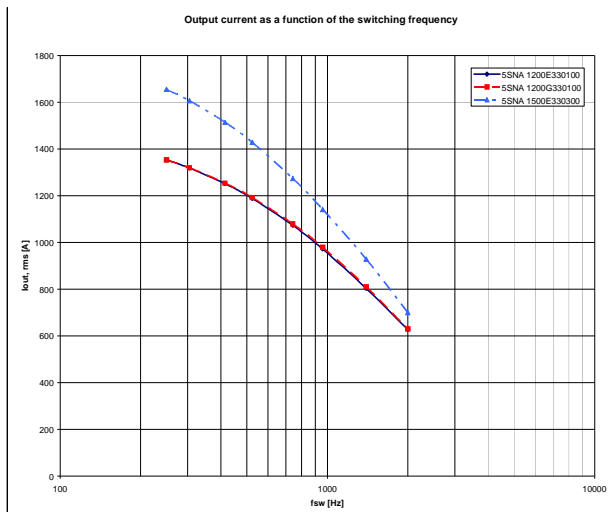

Fig. 36 Performance chart (results)

### Load profile:

This program simulates the transient temperatures and losses of a load profile (Fig. 37). Device model and heat sink have to be selected in the heat sink & transient part of the program. The load profile can contain up to 10 operation points. For the duration of one operation point, the electrical load remains constant. A smooth change in the electrical load can be achieved by splitting it up into several operation points. The result of the simulation is shown in the diagrams of Fig. 10 and can be also extracted as numbers in the output load profile sheet. The data can be used, for example, to calculate life expectancy.

## Load Profile

Simulation Tool for ABB IGBTs

V 6.1, Jan. 2007

Transient Calculations for a specific load profile

Select Heatsink:

water cooled, for 1 HiPak2

Selected Device:

SSNA 1200E330100

HiPak 140\*190mm, SPT, 1200A, 3300V

1 switch(es) per heatsink

Start Temperatures

TA [°C]	TH [°C]	Tj IGBT [°C]	Tj Diode [°C]
40	50	55	55

TA [°C]	TH [°C]	Tj IGBT [°C]	Tj Diode [°C]
40	50	55	55

INPUT

CONFIRMATION

OP*	output current [A]	DC link voltage [V]	output frequency [Hz]	switching frequency [Hz]	modulation index	load power factor cos φ	pulse duration [s]
1	1350	1800	10	800	0.20	0.70	10
2	1200	1800	22	800	0.44	0.80	10
3	1100	1800	35	800	0.70	0.85	20
4	1000	1800	50	800	1.00	0.85	30
5	700	1800	60	800	1.00	0.90	120
6	1000	1800	50	800	1.00	-0.85	20
7	1100	1800	35	800	0.70	-0.85	15
8	1200	1800	22	800	0.44	-0.80	10
9	1250	1800	10	800	0.20	-0.60	10
10	1	1800	5	800	0.10	0.50	40

output current [A]	DC link voltage [V]	output frequency [Hz]	switching frequency [Hz]	modulation index	load power factor cos φ
1350	1800	10	800	0.2	0.7
1200	1800	22	800	0.44	0.8
1100	1800	35	800	0.7	0.85
1000	1800	50	800	1	0.85
700	1800	60	800	1	0.9
1000	1800	50	800	1	-0.85
1100	1800	35	800	0.7	-0.85
1200	1800	22	800	0.44	-0.8
1250	1800	10	800	0.2	-0.6
0.5	1800	5	800	0.1	0.5

\* Numbers have to be 1, 2, 3... 10

End Temperatures

TH [°C]	Tj IGBT [°C]	Tj Diode [°C]
53	56	56

Statistics: Tj IGBT [°C] Tj Diode [°C] Tc IGBT [°C] Tc Diode [°C] Th [°C]

min	55.2	55.4	54.0	54.0	50.0
max	118.4	122.5	90.0	91.8	67.6
average	96.4	94.4	79.5	78.5	61.4
delta	63.2	67.1	36.1	37.8	17.6

Operation points are only considered if in subsequent order (acc. rows). To omit calculation of an operation point leave the number empty.

Fig. 37 Input fields for the load profile calculation.



## Load Profile

n Results are shown in two diagrams

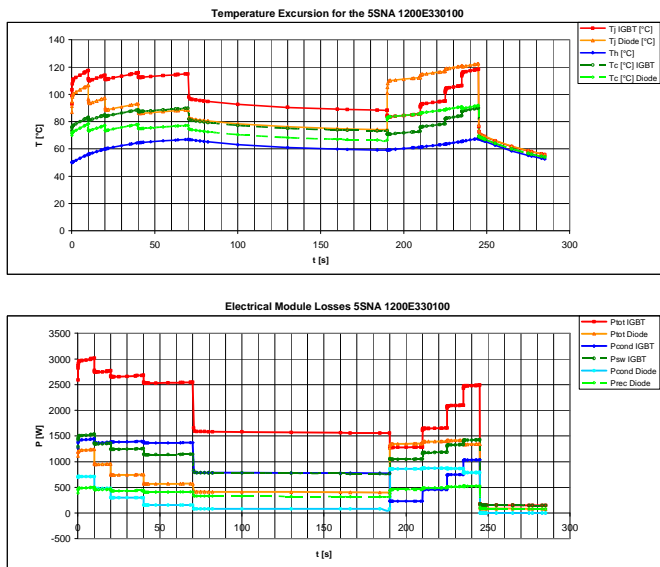

Fig. 38 Load profile calculation results in form of a temperature diagram.

### 3.2.2 Creating models

The simulation tool comes complete with an extensive library for most available ABB HiPak modules. The library is regularly updated with new products as they become available. Nevertheless, it may be desirable to create one's own device models. For this reason the simulation tool allows up to three custom models.

The necessary parameters are:

- Conduction losses at 25 & Tvj(op) – usually 125 °C
- Switching losses 25 & Tvj(op) – usually 125 °C
- Thermal impedance (junction-case)
- Thermal interface resistance (case to heat-sink)

New device models can be specified in the section input.

The following Figs. 39 to 44 describe how a model can be generated:

### General

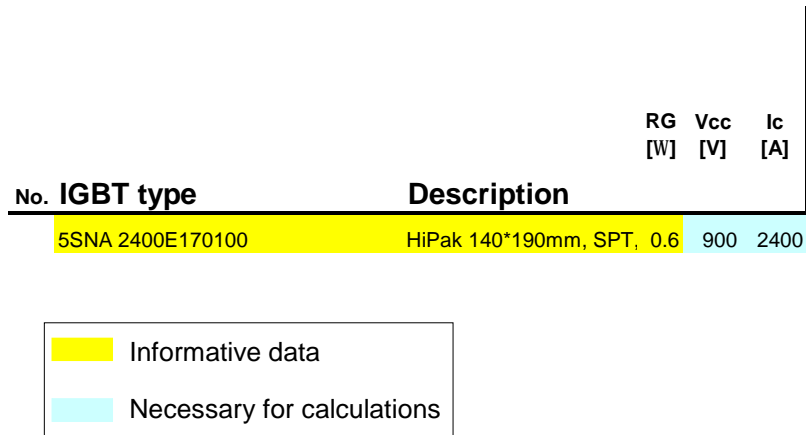

Fig. 39 Input fields for the general description of the module.

### IGBT losses

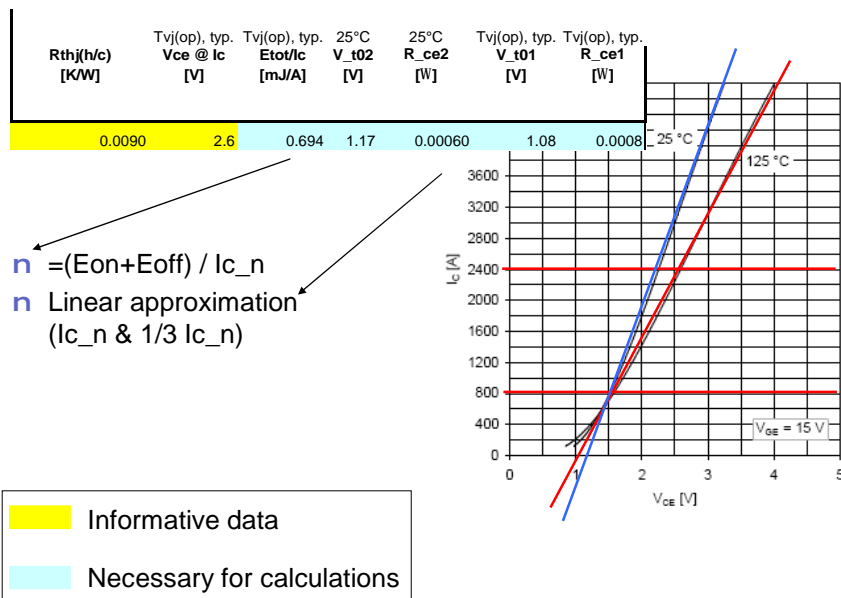

Fig. 40 Input fields for the IGBT loss characteristics.

### Diode losses

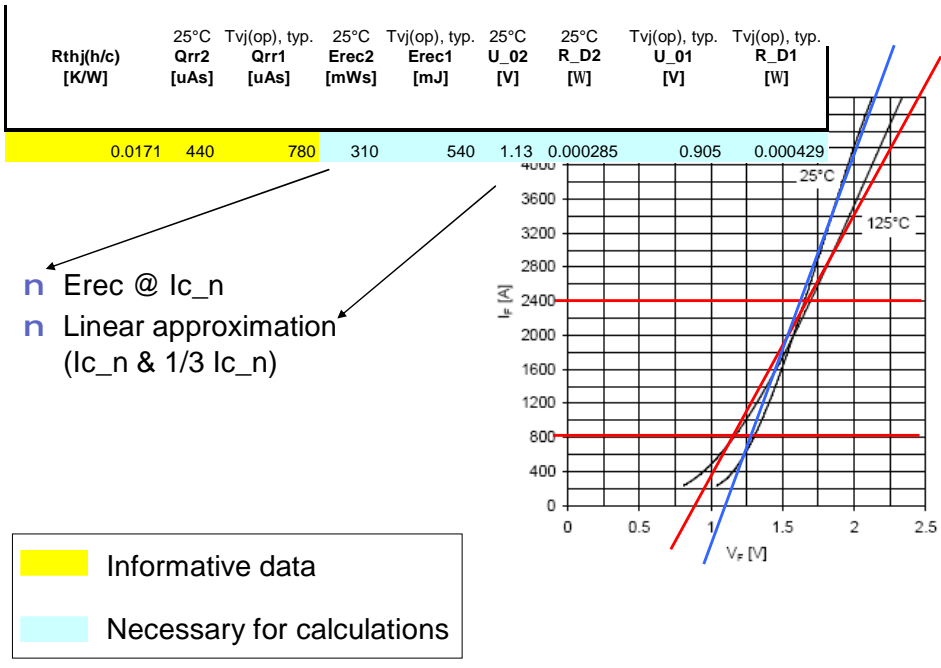
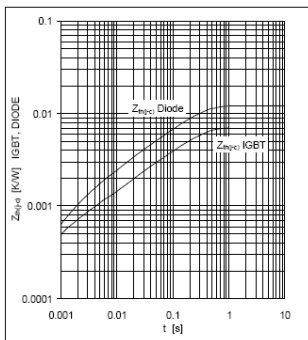

Fig. 41 Input fields for the diode loss characteristics

### .. more

25°C R_CC'+EE' [mΩ]	comments	25°C, typ. Etot/Ic [mJ/A]	IGBT ZthJC	R1 [K/W]	tau1 [s]	R2 [K/W]	tau2 [s]	R3 [K/W]	tau3 [s]
0.06	2004-08-04	0.560		0.00506	0.20290	0.00120	0.02030	0.00050	0.00201

- n Internal connection resistance (wire bonds usually included in VCEsat for ABB Modules)
- n  $= (E_{on} + E_{off}) / I_{c\_n}$  - IGBT switching losses @ 25 °C
- n Thermal impedance of the IGBT & Diode



Analytical function for transient thermal impedance:

$$Z_{th(j-c)}(t) = \sum_{i=1}^n R_i (1 - e^{-t/\tau_i})$$

	i	1	2	3	4
IGBT	R <sub>i</sub> (K/KW)	5.059	1.201	0.495	0.246
	τ <sub>i</sub> (ms)	202.9	20.3	2.01	0.52
DIODE	R <sub>i</sub> (K/KW)	8.432	1.928	0.866	0.839
	τ <sub>i</sub> (ms)	210	29.6	7.01	1.49

Fig. 42 Input fields for the internal resistance and the thermal impedance.

## Polynomial approximation of switching losses

IGBT			Diode		
$E_{sw}=a+b \cdot I_c \cdot I_c^2$ [mJ]			$E_{rec}=a+b \cdot I_c \cdot I_c^2$ [mJ]		
a	b	c	a	b	c
2.330E+02	2.800E-01	1.380E-04	7.600E+01	3.820E-01	-4.530E-05

n Either from a good data sheet

n If graph not available the value for  $E_{sw}/I_c \cdot n$  resp.  $E_{rec}/I_c \cdot n$  is taken for the factor "b"

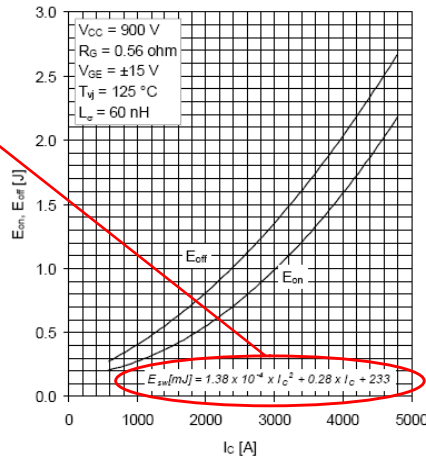

Fig. 43 Input fields for the polynomial approximation of the switching losses.

## Base plate or not

	IGBT	diode	
	Rth CH	Rth CH	Tvj(op)
reference	[K/W]	[K/W]	[°C]
Tc [°C]	0.009	0.018	125



n Tc [°C] indicates a module with base plate

n For base-less modules "Th [°C]" has to be specified as reference

n Interface resistance values are specified individual per IGBT / Diode

n Tvj(op) specifies the temperature at which the switching and conduction losses are specified for elevated temperatures

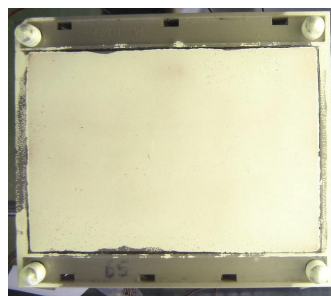

Fig. 44 Input fields for the thermal resistance case to heat-sink and a description how to deal with devices without base plate.

---

## 4 Additional notes

### 4.1 References

- 1) IEC 60146 "Semiconductor convertors"
- 2) IEC 60664-1 (1992) "Insulation Co-ordination Within Low-Voltage Systems"
- 3) IEC 60747 "Semiconductor Devices"
- 4) 5SYA2039 "Mounting instructions for HiPak Modules"
- 5) 5SYA2042 "Failure rates of HiPak modules due to cosmic ray"
- 6) 5SYA2043 "Load cycling capability of HiPaks"
- 7) 5SYA2045 "Thermal runaway during blocking"
- 8) 5SYA2051 "Voltage ratings of high power semiconductors"
- 9) 5SYA2057 "IGBT Diode SOA"
- 10) 5SYA2058 "Surge currents for IGBT Diodes"
- 11) 5SZK9120 "Specification of environmental class for HiPak, Operation (Traction)"

The application notes, references 4 - 10, are available at [www.abb.com/semiconductors](http://www.abb.com/semiconductors). The environmental specification, reference 11, is available upon request.

### 4.2 Application support

For further information please contact:

Customer Support:

Raffael Schnell

Phone +41 58 5861 366, fax +41 58 5861 306

e-mail [raffael.schnell@ch.abb.com](mailto:raffael.schnell@ch.abb.com)

Address:

**ABB Switzerland Ltd**

**Semiconductors**

Fabrikstrasse 3

CH-5600 Lenzburg

Switzerland

E-Mail [abbsem@ch.abb.com](mailto:abbsem@ch.abb.com)

Internet [www.abb.com/semiconductors](http://www.abb.com/semiconductors)

Data sheets for the devices, the simulation tool and your nearest sales office can be found at the ABB Switzerland Ltd, Semiconductors internet website:

[http:// www.abb.com/semiconductors](http://www.abb.com/semiconductors)