

- O RINGS ■
- GASKETS ■
- BOILER MAINTENANCE ■
- ◀ **MECHANICAL SEALS** ■
- PUMP PACKING'S ■
- ROTARY SHAFT SEALS ■
- PRESSURE GAUGES ■
- INDUSTRIAL STRENGTH ADHESIVES ■
- CIRCLIPS & BONDED WASHERS ■
- PNEUMATIC CYLINDER SEALS ■
- HYDRAULIC CYLINDER SEALS ■
- EXTRUSIONS ■
- SHEETING ■

# ABBHEY SEALS ELASTOMERIC BELLOWS TYPE SEALS



## INTRODUCTION

Abbey Seals offer an extensive range of technically efficient and highly versatile, elastomeric bellows seals, suitable for practically any application dimensions, via our comprehensive standard range, or through special manufacture to individual requirements.

## APPLICATIONS

The Abbey Seals bellows seals designs are highly recommended for duties with media containing solids and for hygienic applications, due to their non-dogging, self adjusting and robust design. These very reliable seals are also customisable, as they can be specially produced to any working length and seat housing configuration. Suitable for pumps, mixers, agitators, compressors and other rotary shaft equipment.

## STANDARD ABBEY SEALS BELLOWS TYPES

### Type 14DIN Series

Universal compact DIN seals to suit three standard DIN working lengths.

### Type 19 Series

Robust bellows seal with non-DIN cross-section, available in three standard DIN working lengths and with stationaries to suit all common European housing sizes.

### Types 1511/1511J

Compact DIN profile, ANSI-compliant, bellows seals to suit the most common, American standard working lengths, with a choice of boot or 'O'-Ring stationaries to suit American housing sizes.

### Type 1520

DIN profiled bellows seal to suit common European working length and housing sizes. Seal has same working length and seat as the Abbey Seals Type 20 and Type A2 seals.

### Type 1724 Series

Metal encased, rubber bellows seals to full DIN24960 (EN12756) LTK compatibility. The Abbey Seals seal face is retained to avoid damage during seal installation, a common problem with competitor seal designs.

## STANDARD COMPONENTS.

(All Types except Type 1724)

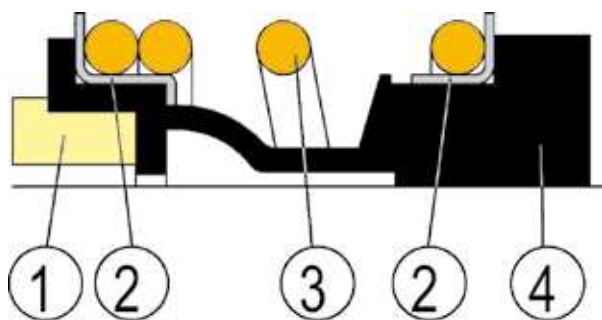

No	Description	No	Description
1	Face	3	Coil
2	Retaining Plates	4	Bellows

## STICTION

The use of two identical Silicon Carbide face materials in certain applications can result in the faces ringing together. Such action is rare, but such face Stiction can potentially be a problem, where the rotary faces are not positively driven, which applies to all styles in this section except for Type 1724. As a most effective way to prevent two SIC faces ringing together, Abbey Seals recommend a Sintered Silicon Carbide (matt lapped) rotary supplied with a Reaction Bonded Silicon Carbide (shiny lapped) stationary, providing both a differential material along with differential lapping.

## ABBEE SEALS DESIGN ADVANTAGES

### Range

Comprehensive range of Bellows Seals, with more working lengths and seat choices and our compact DIN profile designs, than any other mechanical seal manufacturer.

### Material Quality

Wide range of high quality elastomers and seal face materials readily available.

### Design

An ingenious robust, non-fretting and non-dogging bellows design, capable of accommodating seal face wear, shaft misalignment and tolerances, due to Abbey Seals' attention to detail during the design process. The rotary face is resiliently mounted with no bonded joints and therefore will not sustain wear nor damage when in contact with a hard face material. The bellows have no moulded joints and are not subjected to torsional stresses.

These design features and our proven design face width and loading standards, provide increased seal performance, capability and life.

### Retained Components

One sole unit, with no loose parts. The result is an easy fitting, bi-directional seal which is less prone to damage.

### Designed for O.E.M.'s

The Type 14/15/17 Series have been designed as Abbey Seals' O.E.M. range of seals and offer;

- Better performance, capability and life compared to standard Parallel Spring Seals.
- Suitable for a wide variety of applications and media.
- Customisable to any working length, seat housing dimensions, elastomer colours and name etc. Allowing a unique seal to be marketed by O.E.M.'s, as their own design, which won't be sold elsewhere.
- Very cost competitive to produce, especially in larger sizes and hard faces.

### Reliability

These are proven very effective designs, highly utilised in many applications. They give extremely reliable performance based upon the bellows' design, high strength and flexibility. Abbey Seals' thorough Quality Control Systems ensure correct and reliable supply.

## ABBEE SEALS BELLOWS TYPE SEALS PV CHART

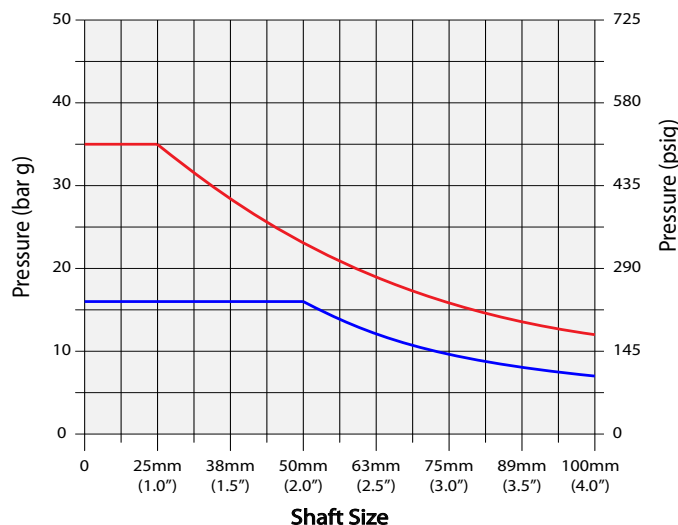

CHART BASED UPON: CARBON VS REACTION BONDED SILICON CARBIDE SEAL FACES

1724

14DIN /15 / 19 SERIES

# TYPES 14DIN / 142DIN / 143DIN\*



Photo illustrates Type 14DIN

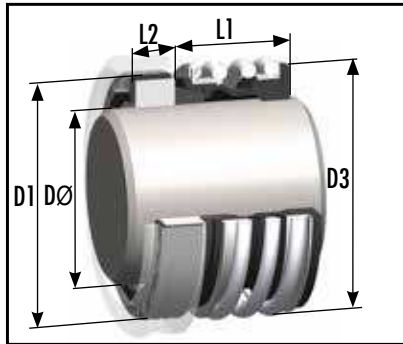

Universal compact DIN seal and stationary with a choice of DIN working lengths. The robust, heavy duty bellows design provides excellent flexibility and durability.

Type 14DIN series is supplied as standard with Type 19B boot-mounted stationaries, to give full DIN24960 (EN12756) dimension compatibility. For the most commonly specified 'O'-Ring mounted stationary alternative, please see the Type 14DINS series opposite.

## ABBEY SEALS STANDARD SIZES

Metric Shaft Size DØ	Size Code	D1	D3	TYPE 14DIN L1	TYPE 142DIN L1	TYPE 143DIN L1	L2	TYPE 142DIN L1K	TYPE 143DIN L1N
10	0100	21.00	20.00	13.40	25.90	33.40	6.60	32.50	40.00
12	0120	23.00	22.00	14.40	25.90	33.40	6.60	32.50	40.00
14	0140	25.00	24.00	14.40	28.40	33.40	6.60	35.00	40.00
15	0150	27.00	25.00	14.40	28.40	33.40	6.60	35.00	40.00
16	0160	27.00	26.00	14.40	28.40	33.40	6.60	35.00	40.00
18	0180	33.00	32.00	18.50	30.00	37.50	7.50	37.50	45.00
20	0200	35.00	34.00	18.50	30.00	37.50	7.50	37.50	45.00
22	0220	37.00	36.00	18.50	30.00	37.50	7.50	37.50	45.00
24	0240	39.00	38.00	18.50	32.50	42.50	7.50	40.00	50.00
25	0250	40.00	39.00	18.50	32.50	42.50	7.50	40.00	50.00
28	0280	43.00	42.00	24.50	35.00	42.50	7.50	42.50	50.00
30	0300	45.00	44.00	25.50	35.00	42.50	7.50	42.50	50.00
32	0320	48.00	46.00	25.50	35.00	47.50	7.50	42.50	55.00
33	0330	48.00	47.00	25.50	35.00	47.50	7.50	42.50	55.00
35	0350	50.00	49.00	26.50	35.00	47.50	7.50	42.50	55.00
38	0380	56.00	54.00	29.00	36.00	46.00	9.00	45.00	55.00
40	0400	58.00	56.00	29.00	36.00	46.00	9.00	45.00	55.00
43	0430	61.00	59.00	29.00	36.00	51.00	9.00	45.00	60.00
45	0450	63.00	61.00	29.00	36.00	51.00	9.00	45.00	60.00
48	0480	66.00	64.00	31.00	36.00	51.00	9.00	45.00	60.00
50	0500	70.00	66.00	30.50	38.00	50.50	9.50	47.50	60.00
53	0530	73.00	69.00	29.00	36.50	59.00	11.00	47.50	70.00
55	0550	75.00	71.00	29.00	36.50	59.00	11.00	47.50	70.00
58*	0580	78.00	78.00	32.00	41.50	59.00	11.00	52.50	70.00
60	0600	80.00	80.00	34.00	41.50	59.00	11.00	52.50	70.00
65	0650	85.00	85.00	34.00	41.50	69.00	11.00	52.50	80.00
70*	0700	92.00	90.00	33.70	48.70	68.70	11.30	60.00	80.00
75*	0750	97.00	99.00	40.70	48.70	68.70	11.30	60.00	80.00
80*	0800	105.00	104.00	40.50	48.00	78.00	12.00	60.00	90.00
85*	0850	110.00	109.00	38.50	46.00	76.00	14.00	60.00	90.00
90*	0900	115.00	114.00	38.50	51.00	76.00	14.00	65.00	90.00
95*	0950	120.00	119.00	38.50	51.00	76.00	14.00	65.00	90.00
100*	1000	125.00	124.00	38.50	51.00	76.00	14.00	65.00	90.00

Please note: Type 142DIN is guaranteed ex-stock in every size to 100mm and material shown, except Tungsten Carbide. Type 14DIN is guaranteed ex-stock in every size and material shown, unless the size and / or material is asterisked\*. Type 143DIN, although not part of the Abbey Seals guaranteed stock range, is ex-stock in most sizes and materials. Most asterisked sizes of T142 / 143 DIN are stocked in some, but not all, materials. And the asterisked materials in many sizes.

GUARANTEED STOCK MATERIALS AND FACE MATERIAL CODE					
Seal And Seat Assembly		Rotary Face		Stationary Face	
Face Reference Term	Code	Material	Code	Material	Code
SOFT	C	M106K Carbon	C	99% Ceramic	A
SOFT VS HARD	D	M106K Carbon	C	VES2 RB SiC	S
HARD VS SOFT	X	Non-Standard: Please use alternative shown here or enquire			
HARD	SS	WNV2 SINSIC Carbide	R	VES2 RB SiC	S
HARD 1st ALT	H	Tungsten Carbide*	H	Tungsten Carbide*	H
Guaranteed Stock Elastomers: Viton®, E.P. and Nitrile			Guaranteed Stock Metallurgy: 304SS		

## Suggested Operating Limits

Maximum Operating Pressure Limits primarily depend upon Face Materials, Shaft Size, Speed and Media. Please refer to the Seal Type Specific PV Chart, found at the front of this Brochure Section, in combination with the Vulcan Multiplying Factors found in Technical and Material Standards Section 2.

# TYPES 14DINS / 142DINS / 143DINS\*

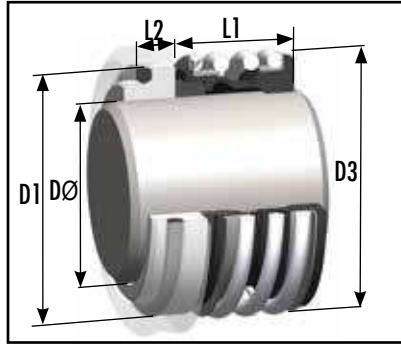

Universal compact DIN seal and stationary with a choice of DIN working lengths. The robust, heavy duty bellows design provides excellent flexibility and durability.

Type 14DINS series is supplied as standard with Type 8 DIN SHORT 'O'-Ring-mounted stationaries, to give full DIN24960 (EN12756) dimension compatibility. For the most commonly specified boot-mounted stationary alternative, please see the Type 14DIN series opposite.

Photo illustrates Type 14DINS

## ABBEY SEALS STANDARD SIZES

Metric Shaft Size DØ	Size Code	D1	D3	TYPE 14DINS L1	TYPE 142DINS L1	TYPE 143DINS L1	L2	142DINS SEAL + SEAT L1K	143DINS SEAL + SEAT L1N
10	0100	21.00	20.00	13.40	25.90	33.40	6.60	32.50	40.00
12	0120	23.00	22.00	14.40	25.90	33.40	6.60	32.50	40.00
14	0140	25.00	24.00	14.40	28.40	33.40	6.60	35.00	40.00
15	0150	27.00	25.00	14.40	28.40	33.40	6.60	35.00	40.00
16	0160	27.00	26.00	14.40	28.40	33.40	6.60	35.00	40.00
18	0180	33.00	32.00	18.50	30.00	37.50	7.50	37.50	45.00
20	0200	35.00	34.00	18.50	30.00	37.50	7.50	37.50	45.00
22	0220	37.00	36.00	18.50	30.00	37.50	7.50	37.50	45.00
24	0240	39.00	38.00	18.50	32.50	42.50	7.50	40.00	50.00
25	0250	40.00	39.00	18.50	32.50	42.50	7.50	40.00	50.00
28	0280	43.00	42.00	24.50	35.00	42.50	7.50	42.50	50.00
30	0300	45.00	44.00	25.50	35.00	42.50	7.50	42.50	50.00
32	0320	48.00	46.00	25.50	35.00	47.50	7.50	42.50	55.00
33	0330	48.00	47.00	25.50	35.00	47.50	7.50	42.50	55.00
35	0350	50.00	49.00	26.50	35.00	47.50	7.50	42.50	55.00
38	0380	56.00	54.00	29.00	36.00	46.00	9.00	45.00	55.00
40	0400	58.00	56.00	29.00	36.00	46.00	9.00	45.00	55.00
43	0430	61.00	59.00	29.00	36.00	51.00	9.00	45.00	60.00
45	0450	63.00	61.00	29.00	36.00	51.00	9.00	45.00	60.00
48	0480	66.00	64.00	31.00	36.00	51.00	9.00	45.00	60.00
50	0500	70.00	66.00	30.50	38.00	50.50	9.50	47.50	60.00
53	0530	73.00	69.00	29.00	36.50	59.00	11.00	47.50	70.00
55	0550	75.00	71.00	29.00	36.50	59.00	11.00	47.50	70.00
58*	0580	78.00	78.00	32.00	41.50	59.00	11.00	52.50	70.00
60	0600	80.00	80.00	34.00	41.50	59.00	11.00	52.50	70.00
65	0650	85.00	85.00	34.00	41.50	69.00	11.00	52.50	80.00
70*	0700	92.00	90.00	33.70	48.70	68.70	11.30	60.00	80.00
75*	0750	97.00	99.00	40.70	48.70	68.70	11.30	60.00	80.00
80*	0800	105.00	104.00	40.50	48.00	78.00	12.00	60.00	90.00
85*	0850	110.00	109.00	38.50	46.00	76.00	14.00	60.00	90.00
90*	0900	115.00	114.00	38.50	51.00	76.00	14.00	65.00	90.00
95*	0950	120.00	119.00	38.50	51.00	76.00	14.00	65.00	90.00
100*	1000	125.00	124.00	38.50	51.00	76.00	14.00	65.00	90.00

Please note: Type 142DINS is guaranteed ex-stock in every size to 100mm and material shown, except Tungsten Carbide. Type 14DINS is guaranteed ex-stock in every size and material shown, unless the size and / or material is asterisked\*. Type 143DINS, although not part of the Abbey Seals guaranteed stock range, is ex-stock in most sizes and materials. Most asterisked sizes of T14 / 143 DIN are stocked in some, but not all, materials. And the asterisked materials in many sizes.

## Suggested Operating Limits

Maximum Operating Pressure Limits primarily depend upon Face Materials, Shaft Size, Speed and Media. Please refer to the Seal Type Specific PV Chart, found at the front of this Brochure Section, in combination with the Vulcan Multiplying Factors found in Technical and Material Standards Section 2.

GUARANTEED STOCK MATERIALS AND FACE MATERIAL CODE					
Seal And Seat Assembly		Rotary Face		Stationary Face	
Face Reference Term	Code	Material	Code	Material	Code
SOFT	C	M106K Carbon	C	99% Ceramic	A
SOFT VS HARD	D	M106K Carbon	C	VES2 RB SiC	S
HARD VS SOFT	X	Non-Standard: Please use alternative shown here or enquire			
HARD	SS	WNV2 SiNSiC Carbide	R	VES2 RB SiC	S
HARD 1st ALT	H	Tungsten Carbide*	H	Tungsten Carbide*	H
Guaranteed Stock Elastomers: Viton®, E.P. and Nitrile			Guaranteed Stock Metallurgy: 304SS		

Please refer to the Technical and Material Standards Section for advice and information on our full range of materials, guaranteed stock policies and more advice on operating limits.

# TYPES 1511 / 1511J

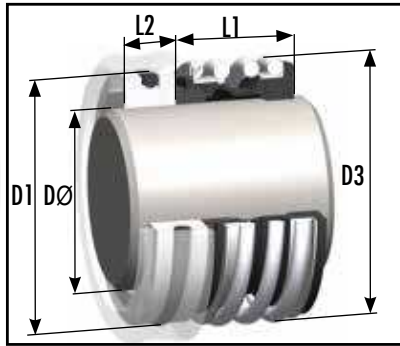

Photo illustrates type 1511J

Rubber bellows seal with narrow DIN profile of Type 14DIN series, that is also compliant to American ANSI seal chamber dimensions. The robust, heavy duty bellows design provides excellent flexibility and durability.

Available as standard with a boot-mounted Type 11 stationary, or as Type 1511J with an 'O'-Ring mounted stationary, commonly preferred in the North American market. Both types have the same installation dimensions.

## ABBEY SEALS STANDARD SIZES

Imperial Shaft Size DØ	Metric Shaft Size DØ	Size Code	D1		D3		L1		L2	
			Imperial	Metric	Imperial	Metric	Imperial	Metric	Imperial	Metric
0.500	12	0120	1.000	25.40	0.866	22.00	0.812	20.62	0.312	7.93
		0127	1.000	25.40	0.866	22.00	0.812	20.62	0.312	7.93
0.625		0158	1.250	31.75	1.024	26.00	0.875	22.23	0.405	10.28
	16	0160	1.250	31.75	1.024	26.00	0.875	22.23	0.405	10.28
	18	0180	1.375	34.93	1.260	32.00	0.875	22.23	0.405	10.28
0.750		0191	1.375	34.93	1.260	32.00	0.875	22.23	0.405	10.28
	20	0200	1.500	38.10	1.339	34.00	0.937	23.80	0.405	10.28
	22	0220	1.500	38.10	1.417	36.00	0.937	23.80	0.405	10.28
0.875		0222	1.500	38.10	1.417	36.00	0.937	23.80	0.405	10.28
	24	0240	1.625	41.28	1.496	38.00	1.000	25.40	0.437	11.10
	25	0250	1.625	41.28	1.535	39.00	1.000	25.40	0.437	11.10
1.000		0254	1.625	41.28	1.535	39.00	1.000	25.40	0.437	11.10
	28	0280	1.750	44.44	1.654	42.00	1.062	26.97	0.437	11.10
1.125		0286	1.750	44.44	1.654	42.00	1.062	26.97	0.437	11.10
	30	0300	1.875	47.63	1.732	44.00	1.062	26.97	0.437	11.10
1.250		0317	1.875	47.63	1.811	46.00	1.062	26.97	0.437	11.10
	32	0320	1.875	47.63	1.811	46.00	1.062	26.97	0.437	11.10
	33	0330	2.000	50.80	1.850	47.00	1.125	28.58	0.437	11.10
1.375		0349	2.000	50.80	1.929	49.00	1.125	28.58	0.437	11.10
	35	0350	2.000	50.80	1.929	49.00	1.125	28.58	0.437	11.10
	38	0380	2.125	53.98	2.126	54.00	1.125	28.58	0.437	11.10
1.500		0381	2.125	53.98	2.126	54.00	1.125	28.58	0.437	11.10
	40	0400	2.375	60.33	2.205	56.00	1.375	34.93	0.500	12.70
1.625		0412	2.375	60.33	2.205	56.00	1.375	34.93	0.500	12.70
	43	0430	2.500	63.50	2.323	59.00	1.375	34.93	0.500	12.70
	44	0440	2.500	63.50	2.402	61.00	1.375	34.93	0.500	12.70
1.750		0444	2.500	63.50	2.402	61.00	1.375	34.93	0.500	12.70
	45	0450	2.625	66.68	2.402	61.00	1.500	38.10	0.500	12.70
1.875		0476	2.625	66.68	2.520	64.00	1.500	38.10	0.500	12.70
	48	0480	2.750	69.85	2.520	64.00	1.500	38.10	0.500	12.70
	50	0500	2.750	69.85	2.625	66.70	1.500	38.10	0.500	12.70
2.000		0508	2.750	69.85	2.625	66.70	1.500	38.10	0.500	12.70
	53	0530	3.000	76.20	2.717	69.00	1.688	42.88	0.562	14.28
2.125		0539	3.000	76.20	2.717	69.00	1.688	42.88	0.562	14.28
	55	0550	3.125	79.38	2.815	71.50	1.688	42.88	0.562	14.28
2.250		0571	3.125	79.38	3.071	78.00	1.688	42.88	0.562	14.28
	60	0600	3.250	82.55	3.150	80.00	1.812	46.02	0.562	14.28
2.375		0603	3.250	82.55	3.150	80.00	1.812	46.02	0.562	14.28
2.500		0635	3.375	85.73	3.268	83.00	1.812	46.02	0.562	14.28
	65	0650	3.375	85.73	3.346	85.00	1.937	49.20	0.562	14.28
2.625		0666	3.375	85.73	3.346	85.00	1.937	49.20	0.562	14.28
2.750		0698	3.500	88.90	3.543	90.00	1.937	49.20	0.626	15.88
	70	0700	3.500	88.90	3.543	90.00	1.937	49.20	0.626	15.88
2.875*		0730	3.750	95.25	3.780	96.00	2.062	52.37	0.626	15.88
	75	0750	3.875	98.43	3.898	99.00	2.062	52.37	0.626	15.88
3.000		0762	3.875	98.43	3.898	99.00	2.062	52.37	0.626	15.88

All types, sizes and materials shown are part of Abbey Seals' Guaranteed Ex-Stock Range, unless marked with an asterisk\*. However, the asterisked seal and / or seat face materials are stocked in many, but not all, sizes.

1511					
GUARANTEED STOCK MATERIALS AND FACE MATERIAL CODE					
Seal And Seat Assembly		Rotary Face		Stationary Face	
Face Reference Term	Code	Material	Code	Material	Code
SOFT	C	M106K Carbon	C	99% Ceramic	A
SOFT VS HARD	D	M106K Carbon	C	VES2 RB SiC	S
SOFT VS METAL	X	Non-Standard: Please use alternative shown here or enquire			
HARD VS SOFT	X	Non-Standard: Please use alternative shown here or enquire			
HARD	SS	WNV2 SINSIC Carbide	R	VES2 RB SiC	S
HARD 1st ALT	H	Tungsten Carbide*	H	Tungsten Carbide*	H
Guaranteed Stock Elastomers: Viton®, E.P. and Nitrile			Guaranteed Stock Metallurgy: 304SS		

1511J					
GUARANTEED STOCK MATERIALS AND FACE MATERIAL CODE					
Seal And Seat Assembly		Rotary Face		Stationary Face	
Face Reference Term	Code	Material	Code	Material	Code
SOFT	C	M106K Carbon	C	99% Ceramic*	A
SOFT VS HARD	D	M106K Carbon	C	VES2 RB SiC	S
SOFT VS METAL	Q	M106K Carbon	C	304 Stainless Steel*	Q
SOFT VS METAL	F	M106K Carbon	C	Ni-Resist	F
HARD	SS	WNV2 SINSIC Carbide	R	VES2 RB SiC	S
HARD 1st ALT	H	Tungsten Carbide*	H	Tungsten Carbide*	H
Guaranteed Stock Elastomers: Viton®, E.P. and Nitrile			Guaranteed Stock Metallurgy: 304SS		

Please refer to the Technical and Material Standards Section for advice and information on our full range of materials, guaranteed stock policies and more advice on operating limits.

# TYPE 1520

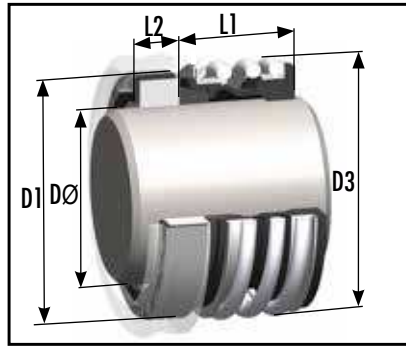

Rubber bellows seal with narrow DIN profile of Type 14DIN series, with installation dimensions to suit common originally UK metric and imperial seal chambers.

The robust, heavy duty bellows design provides excellent flexibility and durability. The Type 1520 is interchangeable with the popular Type 20 parallel-spring diaphragm seals, to provide a bellows seal alternative. The Type 1520 is supplied as standard with a Type 20 boot-mounted stationary.

## ABBEY SEALS STANDARD SIZES

Imperial Shaft Size DØ	Metric Shaft Size DØ	Size Code	D1	D3	L1	L2
	12	0120	27.79	22.00	25.40	8.74
0.500		0127	27.79	22.00	25.40	8.74
	13	0130	27.79	22.00	25.40	8.74
	14	0140	30.95	24.00	25.40	10.32
	15	0150	30.95	25.00	25.40	10.32
0.625		0158	30.95	26.00	25.40	10.32
	16	0160	30.95	26.00	25.40	10.32
	18	0180	34.15	32.00	25.40	10.32
0.750		0191	34.15	32.00	25.40	10.32
	20	0200	35.70	34.00	25.40	10.32
	22	0220	37.30	36.00	25.40	10.32
0.875		0222	37.30	36.00	25.40	10.32
	24	0240	40.50	38.00	25.40	10.32
	25	0250	40.50	39.00	25.40	10.32
1.000		0254	40.50	39.00	25.40	10.32
	28	0280	47.63	42.00	33.34	11.99
1.125		0286	47.63	42.00	33.34	11.99
	30	0300	50.80	44.00	33.34	11.99
1.250		0317	50.80	46.00	33.34	11.99
	32	0320	50.80	46.00	33.34	11.99
	33	0330	53.98	47.00	33.34	11.99
1.375		0349	53.98	49.00	33.34	11.99
	35	0350	53.98	49.00	33.34	11.99
	38	0380	57.15	54.00	33.34	11.99
1.500		0381	57.15	54.00	33.34	11.99
	40	0400	60.33	56.00	33.34	11.99
1.625		0412	60.33	56.00	33.34	11.99
	43	0430	63.50	59.00	40.48	11.99
	44	0440	63.50	61.00	40.48	11.99
1.750		0444	63.50	61.00	40.48	11.99
	45	0450	63.50	61.00	40.48	11.99
1.875		0476	66.68	64.00	40.48	11.99
	48	0480	66.68	64.00	40.48	11.99
	50	0500	69.85	66.70	40.48	13.50
2.000		0508	69.85	66.70	40.48	13.50
	53	0530	73.03	69.00	40.48	13.50
2.125		0539	73.03	69.00	40.48	13.50
	55	0550	76.20	71.50	40.48	13.50
2.250		0571	76.20	78.00	40.48	13.50
	58	0580	79.38	78.00	40.48	13.50
	60	0600	79.38	80.00	40.48	13.50
2.375		0603	79.38	80.00	40.48	13.50
2.500		0635	82.55	83.00	40.48	13.50
	65	0650	92.08	85.00	49.21	13.50
2.625		0666	92.08	85.00	49.21	15.88
2.750		0698	95.25	90.00	49.21	15.88
	70	0700	95.25	90.00	49.21	15.88
2.875*		0730	98.43	96.00	49.21	15.88
	75	0750	101.60	99.00	49.21	15.88
3.000		0762	101.60	99.00	49.21	15.88

All types, sizes and materials shown are part of Abbey Seals' Guaranteed Ex-Stock Range, unless marked with an asterisk\*. However, most asterisked sizes are stocked in some, but not all, materials. And the asterisked materials in many sizes.

## Suggested Operating Limits

Maximum Operating Pressure Limits primarily depend upon Face Materials, Shaft Size, Speed and Media. Please refer to the Seal Type Specific PV Chart, found at the front of this Brochure Section, in combination with the Vulcan Multiplying Factors found in Technical and Material Standards Section 2.

GUARANTEED STOCK MATERIALS AND FACE MATERIAL CODE					
Seal And Seat Assembly		Rotary Face		Stationary Face	
Face Reference Term	Code	Material	Code	Material	Code
SOFT	C	M106K Carbon	C	99% Ceramic	A
SOFT VS HARD	D	M106K Carbon	C	VES2 RB SiC	S
HARD VS SOFT	X	Non-Standard: Please use alternative shown here or enquire			
HARD	SS	WNV2 SiNSiC Carbide	R	VES2 RB SiC	S
HARD 1st ALT	H	Tungsten Carbide*	H	Tungsten Carbide*	H
Guaranteed Stock Elastomers: Viton®, E.P. and Nitrile			Guaranteed Stock Metallurgy: 304SS		

Please refer to the Technical and Material Standards Section for advice and information on our full range of materials, guaranteed stock policies and more advice on operating limits.

# TYPES 19 / 192 / 193

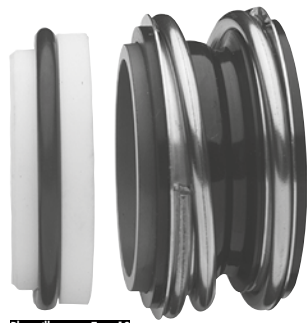
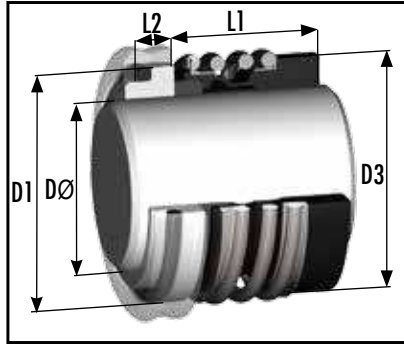

Photo illustrates Type 19



A robust rubber bellows seal, with a wide, larger than DIN, cross section, for optimum flexibility and durability. Type 19 series seals are supplied as standard with a Type 8 STD 'O'-Ring mounted stationary to suit common, originally European, housing dimensions.

Also available as a "Z"-suffix on our stock codes, with bezel-profile Type 8 BEZ stationary, to same installation dimensions, to suit pumps with seat retention plates.

## ABBEY SEALS STANDARD SIZES

Metric Shaft Size DØ	Size Code	D1	D3	TYPE 19 L1	TYPE 192 L1	TYPE 193 L1	L2
10	0100	19.20	20.00	14.50	25.90	33.40	6.60
12	0120	21.60	24.30	15.00	25.90	33.40	5.60
14	0140	24.60	28.50	17.00	28.40	33.40	5.60
15	0150	24.60	28.50	17.00	28.40	33.40	6.60
16	0160	28.00	28.50	17.00	28.40	33.40	7.50
18	0180	30.00	31.00	19.50	30.00	37.50	8.00
20	0200	35.00	36.50	21.50	30.00	37.50	7.50
22	0220	35.00	36.50	21.50	30.00	37.50	7.50
24	0240	38.00	41.10	22.50	32.50	42.50	7.50
25	0250	38.00	41.10	23.00	32.50	42.50	7.50
28	0280	42.00	47.60	26.50	35.00	42.50	9.00
30	0300	45.00	47.60	26.50	35.00	42.50	10.50
32	0320	48.00	51.00	27.50	35.00	47.50	10.50
33	0330	50.00	51.00	27.50	35.00	47.50	11.00
35	0350	52.00	54.50	28.50	35.00	47.50	11.00
38	0380	55.00	57.90	30.00	36.00	46.00	10.30
40	0400	58.00	60.00	30.00	36.00	46.00	10.80
43	0430	62.00	63.80	30.00	36.00	51.00	12.00
45	0450	64.00	65.70	30.00	36.00	51.00	11.60
48	0480	68.40	69.30	30.50	36.00	51.00	11.60
50	0500	69.30	71.80	30.50	38.00	50.50	11.60
53	0530	72.30	76.00	33.00	36.50	59.00	12.30
55	0550	75.40	78.30	35.00	36.50	59.00	13.30
58	0580	78.40	82.50	37.00	41.50	59.00	13.30
60	0600	80.40	85.50	38.00	41.50	59.00	13.30
65*	0650	85.40	90.30	40.00	41.50	69.00	13.00
68*	0680	91.50	94.00	40.00	41.20	68.70	13.70
70*	0700	92.00	97.00	40.00	48.70	68.70	13.00
75*	0750	99.00	102.00	40.00	48.70	68.70	14.00
80*	0800	104.00	109.50	40.00	48.00	78.00	15.00
85*	0850	109.00	116.70	41.00	46.00	76.00	14.80
90*	0900	114.00	122.30	45.00	51.00	76.00	14.80
95*	0950	120.30	127.60	46.00	51.00	76.00	15.80
100*	1000	123.30	132.00	47.00	51.00	76.00	15.80

Please note: Types 19 & 192 are guaranteed ex-stock in all sizes to 100mm and material shown, except Tungsten Carbide.

Type 193 is guaranteed ex-stock in all sizes and materials shown, unless the size and / or material is asterisked\*. However, most asterisked T193 sizes are stocked in some, but not all, materials. And the asterisked T.C. material in many sizes.

GUARANTEED STOCK MATERIALS AND FACE MATERIAL CODE					
Seal And Seat Assembly		Rotary Face		Stationary Face	
Face Reference Term	Code	Material	Code	Material	Code
SOFT	C	M106K Carbon	C	99% Ceramic	A
SOFT VS HARD	D	M106K Carbon	C	VES2 RB SiC	S
HARD VS SOFT	X	Non-Standard: Please use alternative shown here or enquire			
HARD	SS	WNV2 SINSiC Carbide	R	VES2 RB SiC	S
HARD 1st ALT	H	Tungsten Carbide*	H	Tungsten Carbide*	H
Guaranteed Stock Elastomers: Viton®, E.P. and Nitrile			Guaranteed Stock Metallurgy: 304SS		

## Suggested Operating Limits

Maximum Operating Pressure Limits primarily depend upon Face Materials, Shaft Size, Speed and Media. Please refer to the Seal Type Specific PV Chart, found at the front of this Brochure Section, in combination with the Vulcan Multiplying Factors found in Technical and Material Standards Section 2.



# TYPES 19S / 192S / 193S

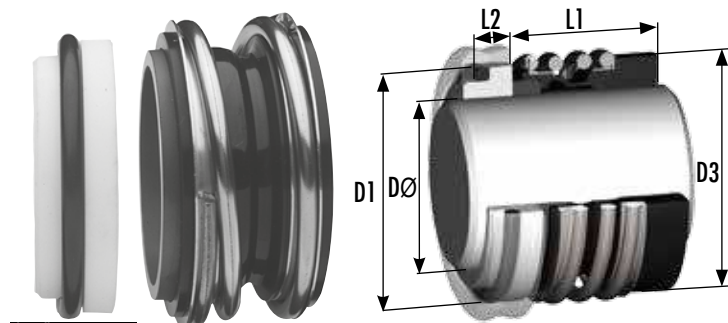

Photo illustrates Type 19S

A robust rubber bellows seal, with a wide, larger than DIN, cross section, for optimum flexibility and durability. Type 19S series seals are supplied as standard with Type 8 DIN SHORT 'O'-Ring mounted stationaries to suit DIN 24960 (EN12756) housing dimensions.

Type 192S complete seal and seat assemblies have working lengths to DIN L1K and Type 193S provides working lengths to DIN L1N.

## ABBEY SEALS STANDARD SIZES

Metric Shaft Size DØ	Size Code	D1	D3	TYPE 19S L1	TYPE 192S L1	TYPE 193S L1	L2	192S SEAL + SEAT L1K	193S SEAL + SEAT L1N
10	0100	21.00	20.00	14.50	25.90	33.40	6.60	32.50	40.00
12	0120	23.00	24.30	15.00	25.90	33.40	6.60	32.50	40.00
14	0140	25.00	28.50	17.00	28.40	33.40	6.60	35.00	40.00
15	0150	27.00	28.50	17.00	28.40	33.40	6.60	35.00	40.00
16	0160	27.00	28.50	17.00	28.40	33.40	6.60	35.00	40.00
18	0180	33.00	31.00	19.50	30.00	37.50	7.50	37.50	45.00
20	0200	35.00	36.50	21.50	30.00	37.50	7.50	37.50	45.00
22	0220	37.00	36.50	21.50	30.00	37.50	7.50	37.50	45.00
24	0240	39.00	41.10	22.50	32.50	42.50	7.50	40.00	50.00
25	0250	40.00	41.10	23.00	32.50	42.50	7.50	40.00	50.00
28	0280	43.00	47.60	26.50	35.00	42.50	7.50	42.50	50.00
30	0300	45.00	47.60	26.50	35.00	42.50	7.50	42.50	50.00
32	0320	48.00	51.00	27.50	35.00	47.50	7.50	42.50	55.00
33	0330	48.00	51.00	27.50	35.00	47.50	7.50	42.50	55.00
35	0350	50.00	54.50	28.50	35.00	47.50	7.50	42.50	55.00
38	0380	56.00	57.90	30.00	36.00	46.00	9.00	45.00	55.00
40	0400	58.00	60.00	30.00	36.00	46.00	9.00	45.00	55.00
43	0430	61.00	63.80	30.00	36.00	51.00	9.00	45.00	60.00
45	0450	63.00	65.70	30.00	36.00	51.00	9.00	45.00	60.00
48	0480	66.00	69.30	30.50	36.00	51.00	9.00	45.00	60.00
50	0500	70.00	71.80	30.50	38.00	50.50	9.50	47.50	60.00
53	0530	73.00	76.00	33.00	36.50	59.00	11.00	47.50	70.00
55	0550	75.00	78.30	35.00	36.50	59.00	11.00	47.50	70.00
58	0580	78.00	82.50	37.00	41.50	59.00	11.00	52.50	70.00
60	0600	80.00	85.50	38.00	41.50	59.00	11.00	52.50	70.00
65*	0650	85.00	90.30	40.00	41.50	69.00	11.00	52.50	80.00
68*	0680	90.00	94.00	40.00	41.20	68.70	11.30	52.50	80.00
70*	0700	92.00	97.00	40.00	48.70	68.70	11.30	60.00	80.00
75*	0750	97.00	102.00	40.00	48.70	68.70	11.30	60.00	80.00
80*	0800	105.00	109.50	40.00	48.00	78.00	12.00	60.00	90.00
85*	0850	110.00	116.70	41.00	46.00	76.00	14.00	60.00	90.00
90*	0900	115.00	122.30	45.00	51.00	76.00	14.00	65.00	90.00
95*	0950	120.00	127.60	46.00	51.00	76.00	14.00	65.00	90.00
100*	1000	125.00	132.00	47.00	51.00	76.00	14.00	65.00	90.00

Please note: Types 19S & 192S are guaranteed ex-stock in all sizes to 100mm and material shown, except Tungsten Carbide. Type 193S is guaranteed ex-stock in all sizes and materials shown, unless the size and / or material is asterisked\*. However, most asterisked T193S sizes are stocked in some, but not all, materials. And the asterisked T.C. material in many sizes.

## Suggested Operating Limits

Maximum Operating Pressure Limits primarily depend upon Face Materials, Shaft Size, Speed and Media. Please refer to the Seal Type Specific PV Chart, found at the front of this Brochure Section, in combination with the Vulcan Multiplying Factors found in Technical and Material Standards Section 2.

GUARANTEED STOCK MATERIALS AND FACE MATERIAL CODE					
Seal And Seat Assembly		Rotary Face		Stationary Face	
Face Reference Term	Code	Material	Code	Material	Code
SOFT	C	M106K Carbon	C	99% Ceramic	A
SOFT VS HARD	D	M106K Carbon	C	VES2 RB SiC	S
HARD VS SOFT	X	Non-Standard: Please use alternative shown here or enquire			
HARD	SS	WNV2 SINSIC Carbide	R	VES2 RB SiC	S
HARD 1st ALT	H	Tungsten Carbide*	H	Tungsten Carbide*	H
Guaranteed Stock Elastomers: Viton®, E.P. and Nitrile			Guaranteed Stock Metallurgy: 304SS		

Please refer to the Technical and Material Standards Section for advice and information on our full range of materials, guaranteed stock policies and more advice on operating limits.

# TYPE 19L

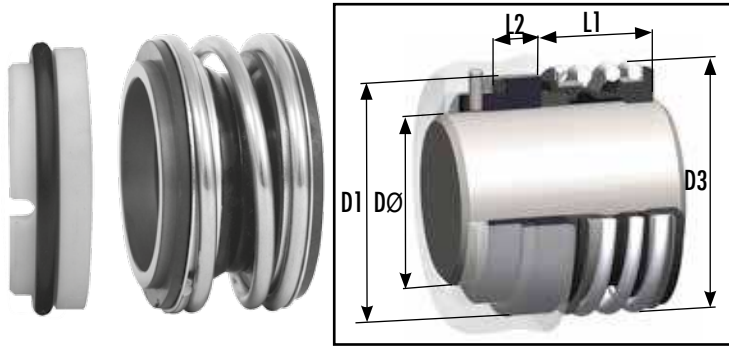

A robust rubber bellows seal, with a wide, larger than DIN, cross section, for optimum flexibility and durability. Type 19L is supplied as standard, with a Type 8 DIN LONG 'O'-Ring mounted stationary with an anti-rotation provision, to suit DIN housing dimensions.

The robust heavy duty bellows design Type 19L is a highly proficient design commonly utilised in heavy duty applications, such as abrasive applications, including waste-water.

## ABBEY SEALS STANDARD SIZES

Metric Shaft Size DØ	Size Code	D1	D3	L1	L2	SEAT SLOT WIDTH	SEAT SLOT DEPTH
10	0100	21.00	20.00	14.50	10.00	4.00	5.00
12	0120	23.00	24.30	15.00	10.00	4.00	5.00
14	0140	25.00	28.50	17.00	10.00	4.00	5.00
15	0150	27.00	28.50	17.00	10.00	4.00	5.00
16	0160	27.00	28.50	17.00	10.00	4.00	5.00
18	0180	33.00	31.00	19.50	11.50	4.00	5.50
20	0200	35.00	36.50	21.50	11.50	4.00	5.50
22	0220	37.00	36.50	21.50	11.50	4.00	5.50
24	0240	39.00	41.10	22.50	11.50	4.00	5.50
25	0250	40.00	41.10	23.00	11.50	4.00	5.50
28	0280	43.00	47.60	26.50	11.50	4.00	5.50
30	0300	45.00	47.60	26.50	11.50	4.00	5.50
32	0320	48.00	51.00	27.50	11.50	4.00	5.50
33	0330	48.00	51.00	27.50	11.50	4.00	5.50
35	0350	50.00	54.50	28.50	11.50	4.00	5.50
38	0380	56.00	57.90	30.00	14.00	5.00	5.50
40	0400	58.00	60.00	30.00	14.00	5.00	5.50
43	0430	61.00	63.80	30.00	14.00	5.00	5.50
45	0450	63.00	65.70	30.00	14.00	5.00	5.50
48	0480	66.00	69.30	30.50	14.00	5.00	5.50
50	0500	70.00	71.80	30.50	15.00	5.00	5.50
53	0530	73.00	76.00	33.00	15.00	5.00	5.50
55	0550	75.00	78.30	35.00	15.00	5.00	5.50
58	0580	78.00	82.50	37.00	15.00	5.00	5.50
60	0600	80.00	85.50	38.00	15.00	5.00	5.50
65	0650	85.00	90.30	40.00	15.00	5.00	5.50
68	0680	90.00	94.00	40.00	18.00	5.00	5.50
70	0700	92.00	97.00	40.00	18.00	5.00	5.50
75	0750	97.00	102.00	40.00	18.00	5.00	5.50
80	0800	105.00	109.50	40.00	18.20	5.00	5.50
85	0850	110.00	116.70	41.00	18.20	5.00	5.50
90	0900	115.00	122.30	45.00	18.20	5.00	5.50
95	0950	120.00	127.60	46.00	17.20	5.00	5.50
100	1000	125.00	132.00	47.00	17.20	5.00	5.50

All types, sizes and materials shown are part of Abbey Seals' Guaranteed Ex-Stock Range, unless marked with an asterisk\*. However, the asterisked seal and / or seat face materials are stocked in many, but not all, sizes.

GUARANTEED STOCK MATERIALS AND FACE MATERIAL CODE					
Seal And Seat Assembly		Rotary Face		Stationary Face	
Face Reference Term	Code	Material	Code	Material	Code
SOFT	C	M106K Carbon	C	99% Ceramic	A
SOFT VS HARD	D	M106K Carbon	C	VES2 RB SiC	S
HARD VS SOFT	X	Non-Standard: Please use alternative shown here or enquire			
HARD	SS	WNV2 SiSiC Carbide	R	VES2 RB SiC	S
HARD 1st ALT	H	Tungsten Carbide*	H	Tungsten Carbide*	H
Guaranteed Stock Elastomers: Viton®, E.P. and Nitrile			Guaranteed Stock Metallurgy: 304SS		

## Suggested Operating Limits

Maximum Operating Pressure Limits primarily depend upon Face Materials, Shaft Size, Speed and Media. Please refer to the Seal Type Specific PV Chart, found at the front of this Brochure Section, in combination with the Vulcan Multiplying Factors found in Technical and Material Standards Section 2.

# TYPES TY 170 / 172 / 173

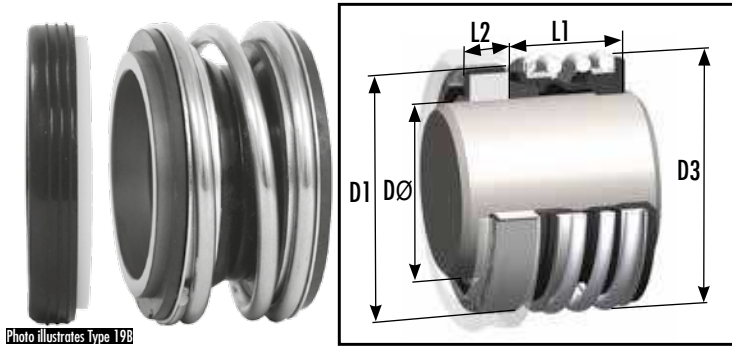

A robust rubber bellows seal, with a wide, larger than DIN, cross section, for optimum flexibility and durability. Type 19B series seals are supplied as standard with Type 19B boot mounted stationaries to suit DIN 24960 (EN12756) housing dimensions.

Type 192B complete seal and seat assemblies have working lengths to meet DIN L1K and Type 193B provides working lengths to DIN L1N.

## ABBEY SEALS STANDARD SIZES

Metric Shaft Size DØ	Size Code	D1	D3	TYPE 19B L1	TYPE 192B L1	TYPE 193B L1	L2	192B SEAL + SEAT L1K	193B SEAL + SEAT L1N
10	0100	21.00	20.00	14.50	25.90	33.40	6.60	32.50	40.00
12	0120	23.00	24.30	15.00	25.90	33.40	6.60	32.50	40.00
14	0140	25.00	28.50	17.00	28.40	33.40	6.60	35.00	40.00
15	0150	27.00	28.50	17.00	28.40	33.40	6.60	35.00	40.00
16	0160	27.00	28.50	17.00	28.40	33.40	6.60	35.00	40.00
18	0180	33.00	31.00	19.50	30.00	37.50	7.50	37.50	45.00
20	0200	35.00	36.50	21.50	30.00	37.50	7.50	37.50	45.00
22	0220	37.00	36.50	21.50	30.00	37.50	7.50	37.50	45.00
24	0240	39.00	41.10	22.50	32.50	42.50	7.50	40.00	50.00
25	0250	40.00	41.10	23.00	32.50	42.50	7.50	40.00	50.00
28	0280	43.00	47.60	26.50	35.00	42.50	7.50	42.50	50.00
30	0300	45.00	47.60	26.50	35.00	42.50	7.50	42.50	50.00
32	0320	48.00	51.00	27.50	35.00	47.50	7.50	42.50	55.00
33	0330	48.00	51.00	27.50	35.00	47.50	7.50	42.50	55.00
35	0350	50.00	54.50	28.50	35.00	47.50	7.50	42.50	55.00
38	0380	56.00	57.90	30.00	36.00	46.00	9.00	45.00	55.00
40	0400	58.00	60.00	30.00	36.00	46.00	9.00	45.00	55.00
43	0430	61.00	63.80	30.00	36.00	51.00	9.00	45.00	60.00
45	0450	63.00	65.70	30.00	36.00	51.00	9.00	45.00	60.00
48	0480	66.00	69.30	30.50	36.00	51.00	9.00	45.00	60.00
50	0500	70.00	71.80	30.50	38.00	50.50	9.50	47.50	60.00
53	0530	73.00	76.00	33.00	36.50	59.00	11.00	47.50	70.00
55	0550	75.00	78.30	35.00	36.50	59.00	11.00	47.50	70.00
58	0580	78.00	82.50	37.00	41.50	59.00	11.00	52.50	70.00
60	0600	80.00	85.50	38.00	41.50	59.00	11.00	52.50	70.00
65*	0650	85.00	90.30	40.00	41.50	69.00	11.00	52.50	80.00
68*	0680	90.00	94.00	40.00	41.20	68.70	11.30	52.50	80.00
70*	0700	92.00	97.00	40.00	48.70	68.70	11.30	60.00	80.00
75*	0750	97.00	102.00	40.00	48.70	68.70	11.30	60.00	80.00
80*	0800	105.00	109.50	40.00	48.00	78.00	12.00	60.00	90.00
85*	0850	110.00	116.70	41.00	46.00	76.00	14.00	60.00	90.00
90*	0900	115.00	122.30	45.00	51.00	76.00	14.00	65.00	90.00
95*	0950	120.00	127.60	46.00	51.00	76.00	14.00	65.00	90.00
100*	1000	125.00	132.00	47.00	51.00	76.00	14.00	65.00	90.00

Please note: Types 19B & 192B are guaranteed ex-stock in all sizes to 100mm and material shown, except Tungsten Carbide. Type 193B is guaranteed ex-stock in all sizes and materials shown, unless the size and / or material is asterisked\*. However, most asterisked T193B sizes are stocked in some, but not all, materials. And the asterisked T.C. material in many sizes.

## Suggested Operating Limits

Maximum Operating Pressure Limits primarily depend upon Face Materials, Shaft Size, Speed and Media. Please refer to the Seal Type Specific PV Chart, found at the front of this Brochure Section, in combination with the Vulcan Multiplying Factors found in Technical and Material Standards Section 2.

GUARANTEED STOCK MATERIALS AND FACE MATERIAL CODE					
Seal And Seat Assembly		Rotary Face		Stationary Face	
Face Reference Term	Code	Material	Code	Material	Code
SOFT	C	M106K Carbon	C	99% Ceramic	A
SOFT VS HARD	D	M106K Carbon	C	VES2 RB SiC	S
HARD VS SOFT	X	Non-Standard: Please use alternative shown here or enquire			
HARD	SS	WNV2 SINSiC Carbide	R	VES2 RB SiC	S
HARD 1st ALT	H	Tungsten Carbide*	H	Tungsten Carbide*	H
Guaranteed Stock Elastomers: Viton®, E.P. and Nitrile			Guaranteed Stock Metallurgy: 304SS		

Please refer to the Technical and Material Standards Section for advice and information on our full range of materials, guaranteed stock policies and more advice on operating limits.

# TYPE 1724

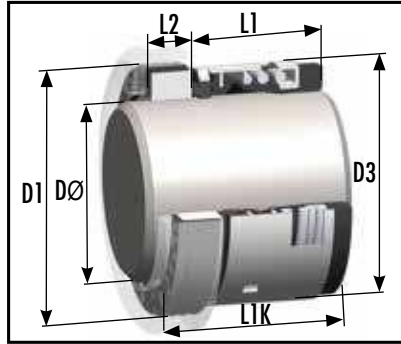

High performance, heavy duty, full convolution rubber bellows seal inside a stainless steel casing. Type 1724 features a retained, positively driven, face, with a non-clogging spring and self-alignment capability, and is fully compliant to DIN24960 (EN12756) dimensions.

Type 1724 is supplied as standard with a Type 24 boot mounted stationary. Please refer to the page opposite, for standard 'O'-Ring mounted seat alternatives.

## ABBEY SEALS STANDARD SIZES

Metric Shaft Size DØ	Size Code	D1	D3	L1	L2	SEAL + SEAT L1K
14	0140	25.00	24.00	26.40	8.60	35.00
16	0160	27.00	26.00	26.40	8.60	35.00
18	0180	33.00	32.00	27.50	10.00	37.50
20	0200	35.00	34.00	27.50	10.00	37.50
22	0220	37.00	36.00	27.50	10.00	37.50
24	0240	39.00	38.00	30.00	10.00	40.00
25	0250	40.00	39.00	30.00	10.00	40.00
28	0280	43.00	42.00	32.50	10.00	42.50
30	0300	45.00	44.00	32.50	10.00	42.50
32	0320	48.00	46.00	32.50	10.00	42.50
33	0330	48.00	47.00	32.50	10.00	42.50
35	0350	50.00	49.00	32.50	10.00	42.50
38	0380	56.00	54.00	34.00	11.00	45.00
40	0400	58.00	56.00	34.00	11.00	45.00
43	0430	61.00	59.00	34.00	11.00	45.00
45	0450	63.00	61.00	34.00	11.00	45.00
48	0480	66.00	64.00	34.00	11.00	45.00
50	0500	70.00	66.00	34.50	13.00	47.50
53	0530	73.00	69.00	34.50	13.00	47.50
55	0550	75.00	71.00	34.50	13.00	47.50
60	0600	80.00	80.00	39.50	13.00	52.50
65	0650	85.00	85.00	39.50	13.00	52.50
68	0680	90.00	88.00	37.20	15.30	52.50
70	0700	92.00	89.00	44.70	15.30	60.00
75	0750	97.00	96.00	44.70	15.30	60.00
80	0800	105.00	104.00	44.30	15.70	60.00
85	0850	110.00	108.00	44.30	15.70	60.00
90	0900	115.00	114.00	49.30	15.70	65.00
95	0950	120.00	118.00	49.30	15.70	65.00
100	1000	125.00	124.00	49.30	15.70	65.00

All types, sizes and materials shown are part of Abbey Seals' Guaranteed Ex-Stock Range, unless marked with an asterisk\*. However, the asterisked seal and / or seat face materials are stocked in many, but not all, sizes.

GUARANTEED STOCK MATERIALS AND FACE MATERIAL CODE					
Seal And Seat Assembly		Rotary Face		Stationary Face	
Face Reference Term	Code	Material	Code	Material	Code
SOFT	C	M106K Carbon	C	99% Ceramic	A
SOFT VS HARD	D	M106K Carbon	C	VES2 RB SiC	S
HARD VS SOFT	G	VES2 RB SiC	S	99% Ceramic	A
HARD	S	VES2 RB SiC	S	VES2 RB SiC	S
HARD 1st ALT	H	Tungsten Carbide*	H	Tungsten Carbide*	H
Guaranteed Stock Elastomers: Viton®, E.P. and Nitrile			Guaranteed Stock Metallurgy: 304SS		

## Suggested Operating Limits

Maximum Operating Pressure Limits primarily depend upon Face Materials, Shaft Size, Speed and Media. Please refer to the Seal Type Specific PV Chart, found at the front of this Brochure Section, in combination with the Vulcan Multiplying Factors found in Technical and Material Standards Section 2.

# TYPES 1724L / 1724S

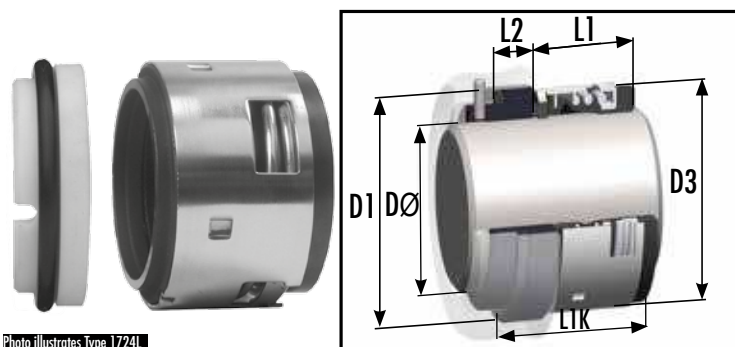

Photo illustrates Type 1724L

High performance, rubber bellows seal inside a stainless steel casing. Type 1724 features a retained, positively driven, face with a non-clogging spring and self-alignment capability, and is fully compliant to DIN24960 (EN12756) dimensions.

Type 1724L is supplied as standard with a Type 24 DIN LONG 'O'-Ring mounted stationary with anti-rotation provision. Type 1724S is supplied with a Type 24 DIN SHORT 'O'-Ring mounted stationary.

## ABBEY SEALS STANDARD SIZES

Metric Shaft Size DØ	Size Code	D1	D3	L1	L2	SEAL + SEAT L1K	SEAT SLOT WIDTH 1724L	SEAT SLOT DEPTH 1724L
14	0140	25.00	24.00	26.40	8.60	35.00	4.00	5.00
16	0160	27.00	26.00	26.40	8.60	35.00	4.00	5.00
18	0180	33.00	32.00	27.50	10.00	37.50	4.00	5.50
20	0200	35.00	34.00	27.50	10.00	37.50	4.00	5.50
22	0220	37.00	36.00	27.50	10.00	37.50	4.00	5.50
24	0240	39.00	38.00	30.00	10.00	40.00	4.00	5.50
25	0250	40.00	39.00	30.00	10.00	40.00	4.00	5.50
28	0280	43.00	42.00	32.50	10.00	42.50	4.00	5.50
30	0300	45.00	44.00	32.50	10.00	42.50	4.00	5.50
32	0320	48.00	46.00	32.50	10.00	42.50	4.00	5.50
33	0330	48.00	47.00	32.50	10.00	42.50	4.00	5.50
35	0350	50.00	49.00	32.50	10.00	42.50	4.00	5.50
38	0380	56.00	54.00	34.00	11.00	45.00	5.00	5.50
40	0400	58.00	56.00	34.00	11.00	45.00	5.00	5.50
43	0430	61.00	59.00	34.00	11.00	45.00	5.00	5.50
45	0450	63.00	61.00	34.00	11.00	45.00	5.00	5.50
48	0480	66.00	64.00	34.00	11.00	45.00	5.00	5.50
50	0500	70.00	66.00	34.50	13.00	47.50	5.00	5.50
53	0530	73.00	69.00	34.50	13.00	47.50	5.00	5.50
55	0550	75.00	71.00	34.50	13.00	47.50	5.00	5.50
60	0600	80.00	80.00	39.50	13.00	52.50	5.00	5.50
63	0630	83.00	83.00	39.50	13.00	52.50	5.00	5.50
65	0650	85.00	85.00	39.50	13.00	52.50	5.00	5.50
68	0680	90.00	88.00	37.20	15.30	52.50	5.00	5.50
70	0700	92.00	89.00	44.70	15.30	60.00	5.00	5.50
75	0750	97.00	96.00	44.70	15.30	60.00	5.00	5.50
80	0800	105.00	104.00	44.30	15.70	60.00	5.00	5.50
85	0850	110.00	108.00	44.30	15.70	60.00	5.00	5.50
90	0900	115.00	114.00	49.30	15.70	65.00	5.00	5.50
95	0950	120.00	118.00	49.30	15.70	65.00	5.00	5.50
100	1000	125.00	124.00	49.30	15.70	65.00	5.00	5.50

All types, sizes and materials shown are part of Abbey Seals' Guaranteed Ex-Stock Range, unless marked with an asterisk\*. However, the asterisked seal and / or seat face materials are stocked in many, but not all, sizes.

## Suggested Operating Limits

Maximum Operating Pressure Limits primarily depend upon Face Materials, Shaft Size, Speed and Media. Please refer to the Seal Type Specific PV Chart, found at the front of this Brochure Section, in combination with the Vulcan Multiplying Factors found in Technical and Material Standards Section 2.

GUARANTEED STOCK MATERIALS AND FACE MATERIAL CODE					
Seal And Seat Assembly		Rotary Face		Stationary Face	
Face Reference Term	Code	Material	Code	Material	Code
SOFT	C	M106K Carbon	C	99% Ceramic	A
SOFT VS HARD	D	M106K Carbon	C	VES2 RB SiC	S
HARD VS SOFT	G	VES2 RB SiC	S	99% Ceramic	A
HARD	S	VES2 RB SiC	S	VES2 RB SiC	S
HARD 1st ALT	H	Tungsten Carbide*	H	Tungsten Carbide*	H
Guaranteed Stock Elastomers: Viton®, E.P. and Nitrile			Guaranteed Stock Metallurgy: 304SS		

Please refer to the Technical and Material Standards Section for advice and information on our full range of materials, guaranteed stock policies and more advice on operating limits.



■ **DUBLIN**

John F. Kennedy Rd  
John F. Kennedy Ind Est  
Dublin 12  
Ireland

**T:** +353 (0)1 427 7900  
**F:** +353 (0)1 450 8181  
**E:** [dublin@abbeyseals.ie](mailto:dublin@abbeyseals.ie)  
**W:** [www.abbeyseals.ie](http://www.abbeyseals.ie)

■ **CORK**

31b Euro Business Park  
Little Island  
Cork  
Ireland

**T:** +353 (0)21 500 3555  
**F:** +353 (0)21 500 3554  
**E:** [cork@abbeyseals.ie](mailto:cork@abbeyseals.ie)  
**W:** [www.abbeyseals.ie](http://www.abbeyseals.ie)

**WWW.ABBEYSEALS.IE**

■ **GASKET CUTTERS** ■ **SEAL DISTRIBUTORS** ■