



**PICOTURN®**  
**Data Sheet**

## **PT2G Series**

**Smart Sensor System for  
Turbocharger Speed Detection, 2<sup>nd</sup> Generation**

September 30, 2014

Document-No: DB\_PT2G\_en V1.5

**Published by acam-messelectronic gmbh**

©acam-messelectronic gmbh 2014

**Legal note**

The information provided by this data sheet is believed to be accurate and reliable. However, acam cannot be held liable for any of its contents, neither for accuracy, nor for completeness. The compiled information is believed correct, though some errors and omissions are likely. We welcome any notification, which will be integrated in succeeding releases.

The acam recommendations are believed useful, the firmware proposals and the schematics operable, nevertheless it is the customer's sole responsibility to modify, test and validate them before setting up any production process.

acam products are not designed for use in medical, nuclear, military, aircraft, spacecraft or life support devices. Nor are they suitable for applications where failure may provoke injury to people or heavy material damage. acam declines any liability with respect to such non-intended use, which remains under the customer's sole responsibility and risk.

Military, space and nuclear use is subject to German export regulations.

acam does not warrant, and it is not implied that the information and/or practice presented here is free from patent, copyright or similar protection. All registered names and trademarks are mentioned for reference only and remain the property of their respective owners. The acam logo and the PICOTURN logo are registered trademarks of acam-messelectronic gmbh, Germany.

**Support / Contact**

For a complete listing of Direct Sales, Distributor and Sales Representative contacts, visit the acam Web site at:

<http://www.acam.de/sales/distributors/>

For technical support you can contact the acam support team or distributors. The contact details of acam are:

support@acam.de

or by phone

+49 7244 7419-0.

## Important Safety Information

### Product Use

PICOTURN products are designed for industrial use. The intended use of the product is the measurement of speed of a turbocharger in a test bench environment or in driving tests. For proper installation and usage please follow the mounting instructions in this document. During operation of the test bench (including the motor and turbocharger), no persons must be present in the test room. For use in driving tests, in which persons may be present, use the product in such a way that in case of malfunctions or error, personnel and equipment are not endangered. Any use other than the one described above is considered as non-intended use and acam declines any liability with respect to such non-intended use.

### Installation

The speed sensor should be installed by a qualified automotive technician. Please carefully read and follow the instructions given in this manual for proper installation and use of the product. Furthermore, please pay attention to any installation instructions given by the turbocharger manufacturer, especially for the mounting of the sensor at the turbocharger and its safe operation. If you have any question or doubts regarding the installation or operation please contact the distributor from whom you purchased the sensor or alternatively contact acam directly.

### Signal words and symbols used

The following symbols and signal words are used in this data sheet.



CAUTION indicates a hazardous situation which, if not avoided, could result in minor or moderate injury



NOTICE is used to address practices not related to physical injury

### Safety messages

The following list provides an overview of potential damages that can occur if the turbocharger sensor system is not operated as outlined in this manual.



Connect an adequate power supply (meeting the specifications for supply voltage and current) in accordance with safety regulations for electrical equipment. Otherwise there is risk of injury and/or damage to or destruction of the sensor and controller box.



Mount the sensor according to the installation instruction in this data sheet and/or the installation instructions of the turbocharger

manufacturer. If the sensor is mounted incorrectly, the sensor itself; the turbocharger housing; or the turbo charger wheel (blades) can be damaged. Particularly in the case where the sensor goes too far into the turbocharger cavity, the wheel blades may be touched and thus the turbo wheel damaged. As a consequence, single blades of the turbo wheel could be detached and go into the motor and cause further damage there.

### **Warranty**

acam warrants to the original purchaser of its PICOTURN products the fitness and merchantability. In case of approved warranty claims acam will repair or replace any products or parts thereof that prove to be defective in workmanship or material, or credit the original purchaser with an amount equal to the original purchase price for a period of one (1) year after purchase. This is the purchaser's sole and exclusive remedy and constitutes the complete financial responsibility of acam for a warranty claim.

If the original purchaser was not the end customer, but a wholesaler (distributor), different warranty regulations and warranty periods may apply. Please direct any request in this case to the distributor first. In either case, for reimbursement or replacement of an alleged defective product, a warranty claim to (a) the distributor or (b) acam directly must be submitted within thirty (30) days and a Return Material Authorization Form completed (available from the distributor or at [support@acam.de](mailto:support@acam.de)).

### **Limitations on warranty**

acam shall not be liable to the end user under any circumstances for any special, incidental or consequential damage, including without limitation, damage to or loss of property other than for the PICOTURN products themselves; damage incurred during installation, repair or replacement; lost profits, revenue or opportunity; losses resulting from or related to downtime of PICOTURN products; loss of use; the cost of replacement transportation, power, or compression; the cost of substitute products; or claims of third parties for such damage, howsoever caused, and whether based on warranty, contract, and/or tort (including negligence, strict liability or otherwise).

acam disclaims all other warranties, expressed or implied.

## Content

1	PT2G Series – Product List .....	6
2	System Description .....	8
3	System Components .....	9
3.1	The Sensor Element.....	9
3.2	Signal Conditioning Box for Power and Various Interfaces .....	10
3.3	Standard Cables, Pin Assignment .....	11
4	Connecting Options .....	12
4.1	Standard Wiring .....	12
4.2	Other Connection Possibilities .....	13
4.3	Vendor Dependent Connecting Options .....	14
5	Sensor Application .....	16
6	Technical Data .....	16
6.1	Vane number.....	19
6.2	Diagnostics .....	19
6.3	Sensors, Mechanical Dimension .....	20
6.4	Technical Data for Specialists .....	21
7	Calibration .....	22
7.1	PICOTURN-CT (“PTCT”) .....	22
7.2	Technical Data .....	22
7.3	Setup .....	23
7.4	Calibration process .....	23
7.5	Verification .....	24
8	Miscellaneous .....	27
8.1	Last Changes .....	27

# 1 PT2G Series – Product List

Part No.	Product	Description			
<b>Intelligent sensors with integrated signal processing and TTL output</b>					
		Sensor length/ thread length	Diameter	Cable length	Temperature range sensor head
1537	PT2G-SM5.3	60 mm/54 mm	M5 x 0.8	0.95 m	-40 °C to +230 °C
1591	PT2G-SM5.5	46 mm/40 mm	M5 x 0.8	0.95 m	-40 °C to +230 °C
1660	PT2G-SM5.6	75 mm/69 mm	M5 x 0.8	0.95 m	-40 °C to +230 °C
1590	PT2G-SM5F.2	41 mm/25 mm	M5 x 0.5	0.95 m	-40 °C to +230 °C
1538	PT2G-SM5F.3	56 mm/40 mm	M5 x 0.5	0.95 m	-40 °C to +230 °C
1666	PT2G-SM5F.5	76 mm/60 mm	M5 x 0.5	0.95 m	-40 °C to +230 °C
<b>New In preparation: H-types for higher temperature and higher sensitivity</b>					
2185	PT2G-H-SM5.3	60 mm/54 mm	M5 x 0.8	0.95 m	-40 °C to +250 °C
t.b.d.	PT2G-H-SM5.5	46 mm/40 mm	M5 x 0.8	0.95 m	-40 °C to +250 °C
t.b.d.	PT2G-H-SM5.6	75 mm/69 mm	M5 x 0.8	0.95 m	-40 °C to +250 °C
t.b.d.	PT2G-H-SM5F.2	41 mm/25 mm	M5 x 0.5	0.95 m	-40 °C to +250 °C
2181	PT2G-H-SM5F.3	56 mm/40 mm	M5 x 0.5	0.95 m	-40 °C to +250 °C
2182	PT2G-H-SM5F.5	76 mm/60 mm	M5 x 0.5	0.95 m	-40 °C to +250 °C
<b>New</b>	H-types: 270°C peak temperature for 5 min, higher sensitivity, for use in critical applications				
<b>Signal Conditioning Boxes</b>					
1526	PT2G-BX	Power supply and signal conditioning box with RS232 interface			
1527	PT2G-BD	Power supply and signal conditioning box with display			
890	PICOTURN-CT	Calibration device for PT2G-BX/BD signal conditioners			

Part No.	Product	Description	
<b>Accessories</b>			
1771	PT2G-XS-01.5	Adapter cable, interconnecting PT2G-SM... sensor and PT2G-Bx. signal conditioning box	1.5 m long
1569	PT2G-XS-03		3 m long
1539	PT2G-XS-05		5 m long
1540	PT2G-XS-10		10 m long
1541	PT2G-C-2B	Power supply cable, 4 mm "banana" connectors, 2 m length Power supply cable, open end, 2 m long Combination cable for power supply and signals (2 x BNC, 2 x "banana" 4 mm), long 3 m / 3.6 m	
1542	PT2G-C-2U		
1659	PT2G-C-2B&2BNC		
1543	PT2G-X-CT	Cable, interconnecting PT2G-Bx box and PICOTURN-CT calibration device	
1767	PT2G-X-BNCM8	Cable, connecting PT2G-BD as a display box to a PTBM box. 1 m long	
1684	PT2G-C-CSM2M	Cable, connecting one PT2G sensor to a "CNTMM" counter minimodule from CSM GmbH, length 2m (also available in 10 m)	
1963 [*]	PT2G-C-ETAS_E441	Cable connecting two sensors PT2G to one "E441" module from ETAS GmbH, length: 2 m	
1667	PT2G-C-IPTRKLM	Cable, connecting one PT2G sensor to an IPETRONIK "SIM-CNT" or "M-FRQ" counter module	

[\*] Please request directly from ETAS, their part number is F-00K-107-568

## 2 System Description

PICOTURN® is a system for measuring the rotational speed of turbochargers. Its functional principle is one-megahertz pulse induction and eddy current discrimination, done with a solenoid sensor that is mounted in the compressor housing through a bore. The sensor detects and counts compressor vanes one by one. When compared to optical detection, this inductive method benefits from its lack of sensitivity to dirt, oil and dust. When compared to the magnetized nut method, the PICOTURN system is safer as there is no concern with nuts coming loose and destroying the charger and the engine. When compared to a competing, entirely analog inductive vane counting system, the fully digital PICOTURN device turns out to be rugged, reliable, simple to use and very cost-effective.

Since 2001 PICOTURN in its original “first” generation has proven to have advantages in prototype vehicles and on engine test benches. It has been successfully used in passenger cars and in commercial vehicles. Made up of discrete electronic components, it has been developed in a continuous improvement process up to its sixth version (“PTBM-V6”). To continue the improvement, it was necessary to achieve a higher degree of integration by creating a dedicated CMOS integrated circuit (ASIC) and, as a result of this chip, the second generation PICOTURN (“PT2G”) was developed.

In the PT2G, part of the remote electronics has now been placed close to the sensor body for under-hood operation. Consequently, cable length and placement of the box have ceased to be an issue. Passenger car engineers can now place the box in the trunk, while commercial car engineers can now use a 10-meter cable and loop it around the cabin hinge.

A further advantage of this new, second generation system is the wealth of interfaces available thus reducing the number of devices and cables needed. This is particularly useful in vehicles. When used in a bi-turbo environment, unique solutions occur that may be advantageous to many customers (i.e. directly connecting sensor elements to commercially available frequency counters providing two or more entry channels). This kind of counter solution is somewhat expensive, so most customers are likely to prefer the inexpensive, dedicated PICOTURN conditioner box offered by ACAM. The measuring chain will then comprise the sensor element, the box and two signal cables plus one supply cable. Alternatively, a combined cable may be used that integrates the supply line. A “combi connector” will then be used instead of the BNC connectors from the first generation system, which are still available. Furthermore, the customer will choose



between pulse-coded, analog voltage coded, or alphanumeric data output (for alphanumeric, opt for the "RS-232" version of the box).

As before, the sensor solenoid is housed in a M5 threaded sleeve with two different pitches and various lengths available. Unlike earlier first-generation versions (PTBM-V1 to V6), the second generation system is no longer compatible with earlier components. First and second generation components must be handled separately. Sensor placement and system operation in general, however, remain unchanged.

### 3 System Components

#### 3.1 The Sensor Element

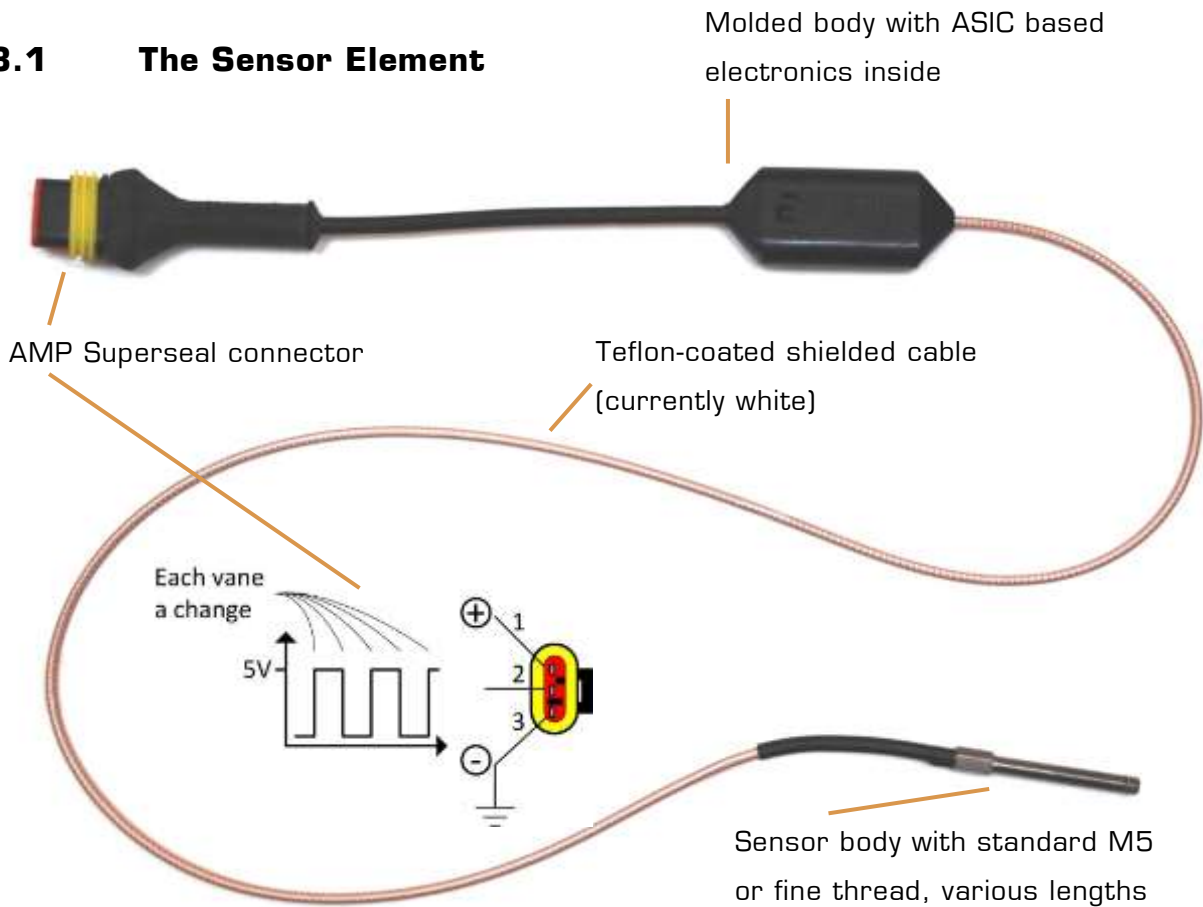

Sensor part number code:  
**Part No. PT2G-SM...**

### 3.2 Signal Conditioning Box for Power and Various Interfaces

Like in the PICOTURN first generation system, the conditioner electronics has been placed in a light gray aluminum housing having the same BNC connectors and vane number selector as before. The female supply plugs have been removed for safety reasons. Instead, there is a 5-pole combination connector integrating power supply and interfaces, wired in parallel to the BNC connectors. Last but not least, the system still has a diagnostics LED, but with re-defined signal codes. Unlike the first generation system, there is now an integrated seven-segment numeric display, which has the option of being replaced by a computer connector (9-pole D-Sub) for numeric data output.

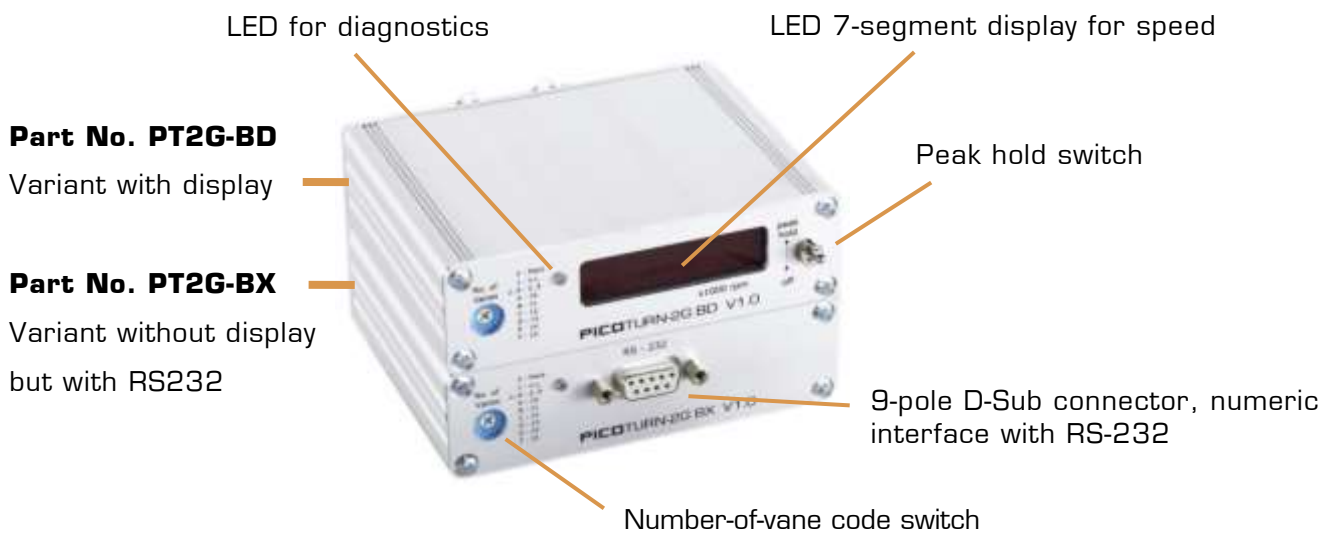

#### Backside both box variants



### 3.3 Standard Cables, Pin Assignment

Supply cable with or without 5 mm banana plugs,  
2 meters in length

Part No. PT2G-C-2B or PT2G-C-2U

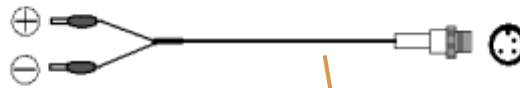
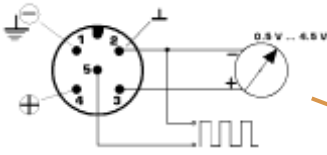

M12-thread 5-pole combination connector pin assignment. Exterior view of the box.

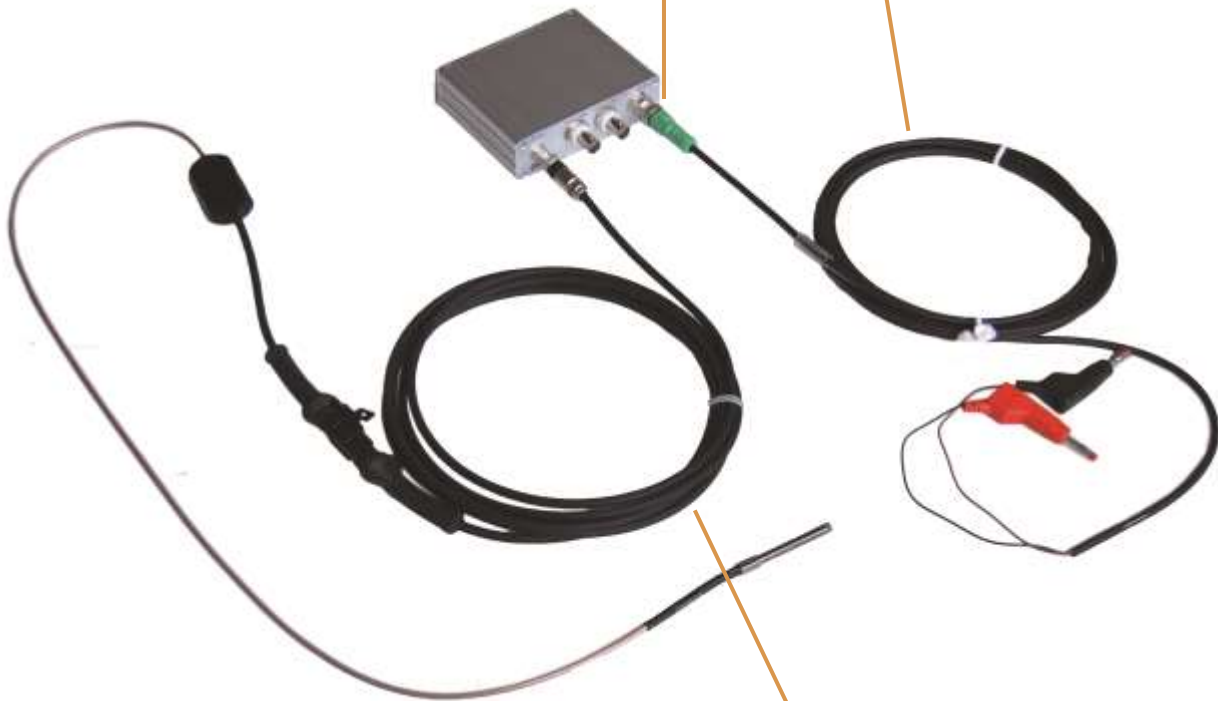

Adapter cable between sensor element and conditioner box. Length 3 meters, 10 meters etc.

**Ref. PT2G-XS-xx**

xx = length in meters (01.5, 03, 05, 10)



## 4 Connecting Options

### 4.1 Standard Wiring

This wiring corresponds to the well-known PICOTURN first generation system.

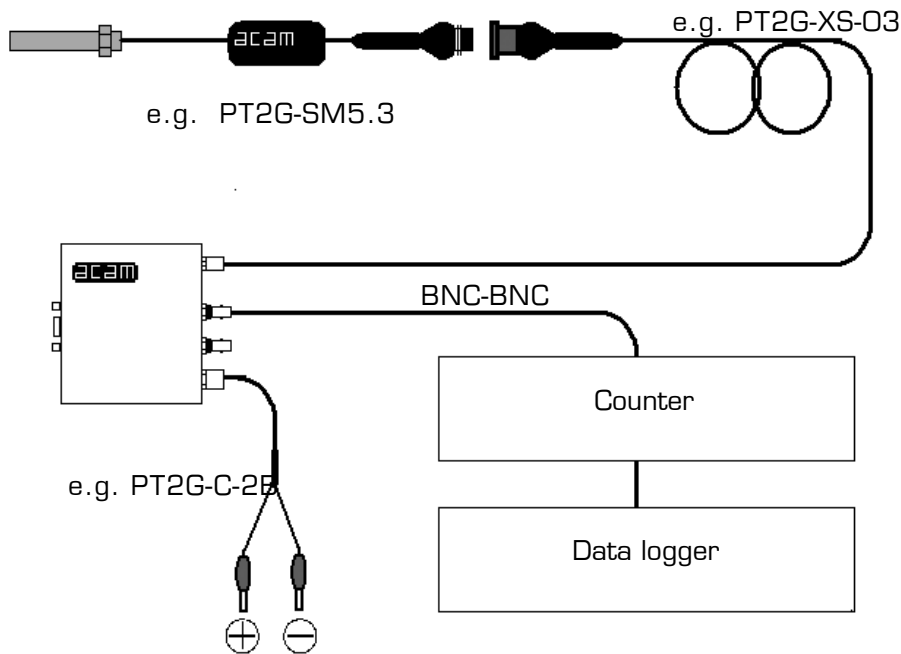
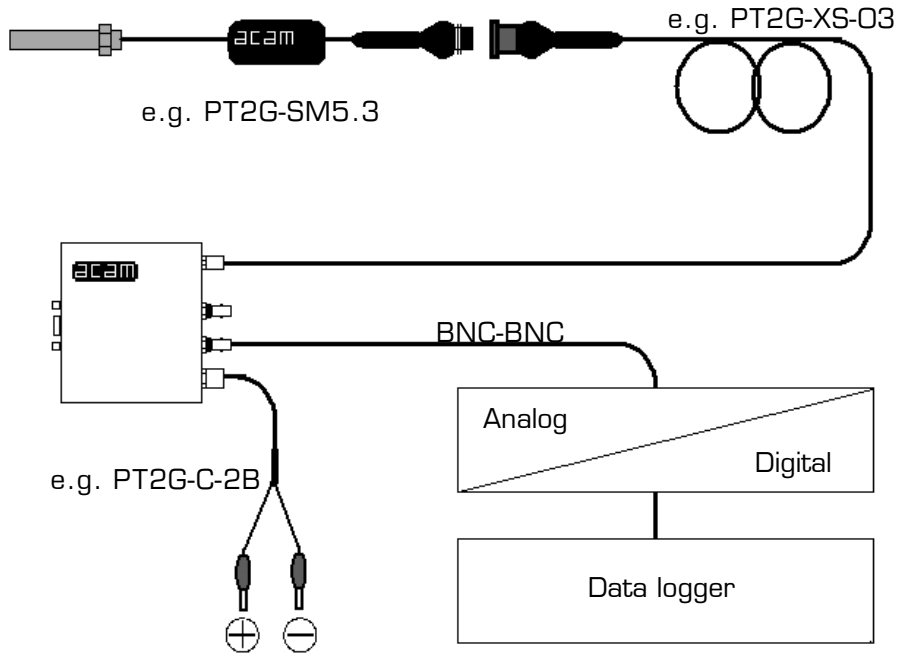

**4.2 Other Connection Possibilities**

To computer, via  
RS-232 at D-Sub, 9-pole

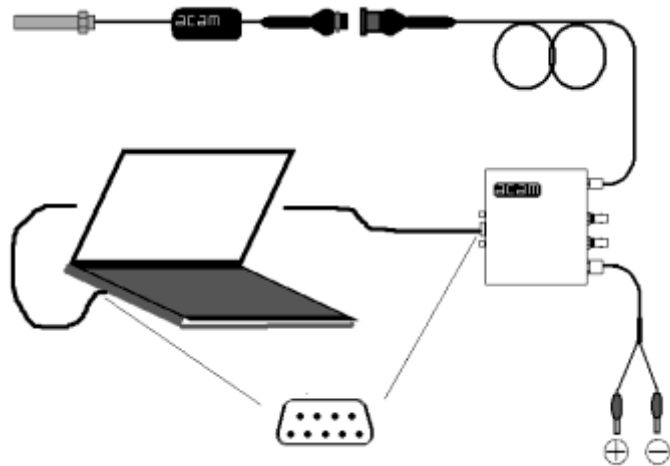

To CAN bus  
Via RS232-to-CAN converter

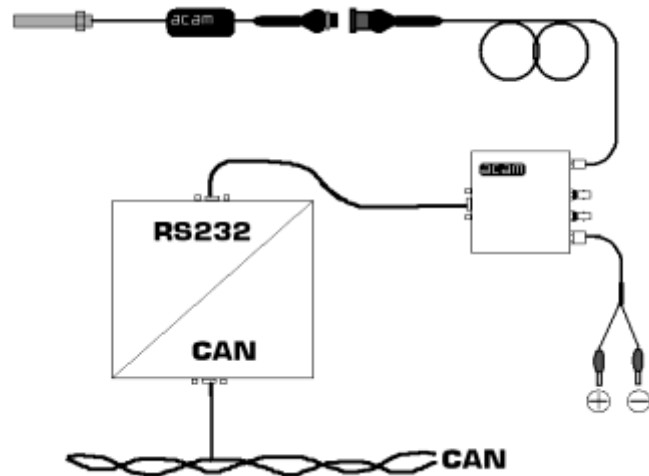

**4.3 Vendor Dependent Connecting Options**

**4.3.1 ETAS**

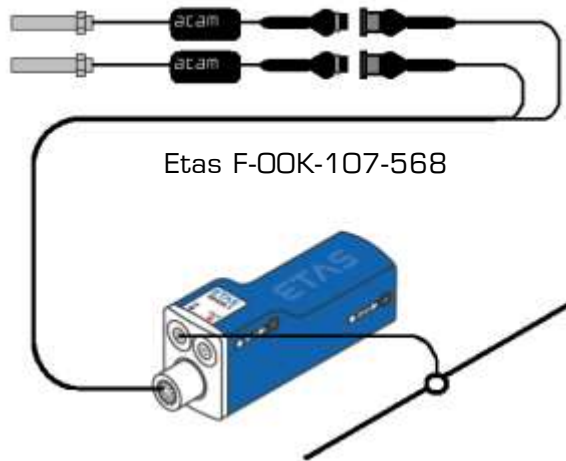

Etas F-00K-107-568

[www.ETAS.com](http://www.ETAS.com)

**4.3.2 IPETRONIK**

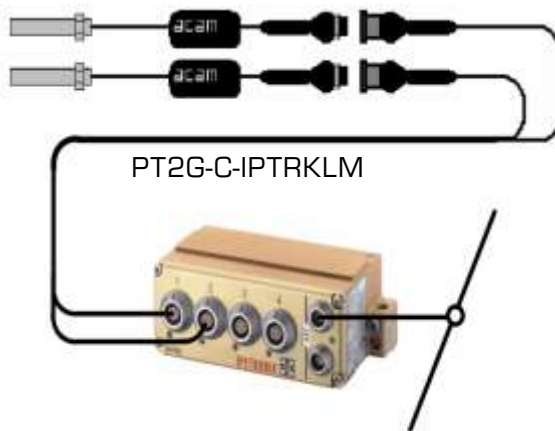

PT2G-C-IPTRKLM

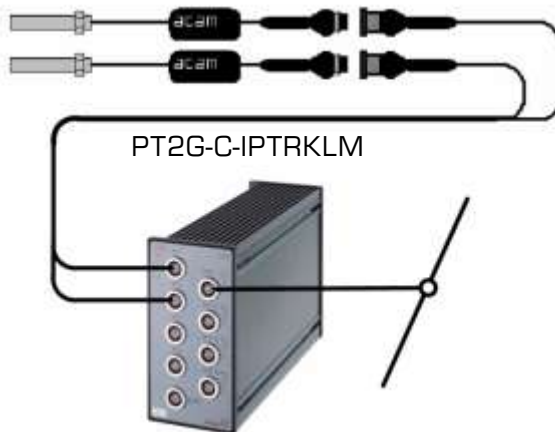

PT2G-C-IPTRKLM

[www.ipetronik.com](http://www.ipetronik.com)

**4.3.3 CSM**

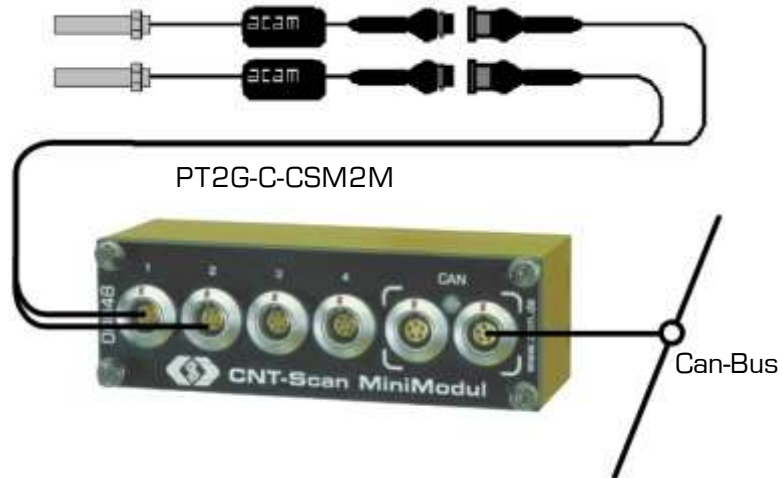

[www.csm.de](http://www.csm.de)

**4.3.4 ATI Accurate Technologies Inc.**

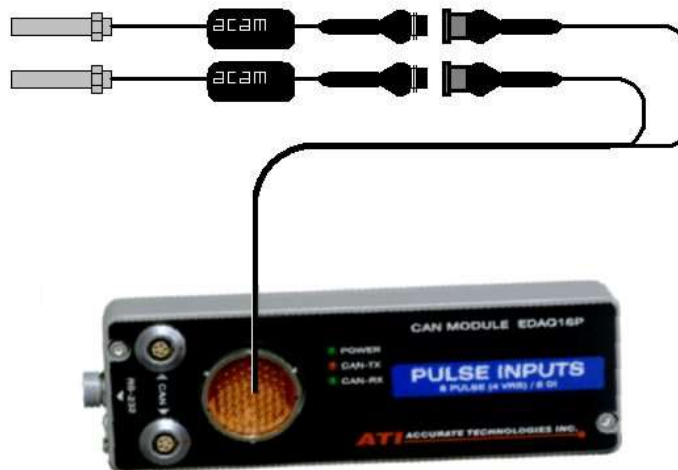

[www.accuratetechnologies.com](http://www.accuratetechnologies.com)

## 5 Sensor Application



Prior to the PICOTURN product installation, be sure that the turbocharger is cool.

The sensor body should be mounted in principle as indicated (see sketch on the right). The compressor housing needs to be removed. Drill a hole into the case and cut a thread. Select the position of the hole so that every vane, both big and small, will be sensed. Place the sensor directly in front of the small vanes (“splitter vanes”), avoiding the vicinity of their upper edge (which could induce error into the system). The system is programmed to sense alternately thicker and thinner vanes.

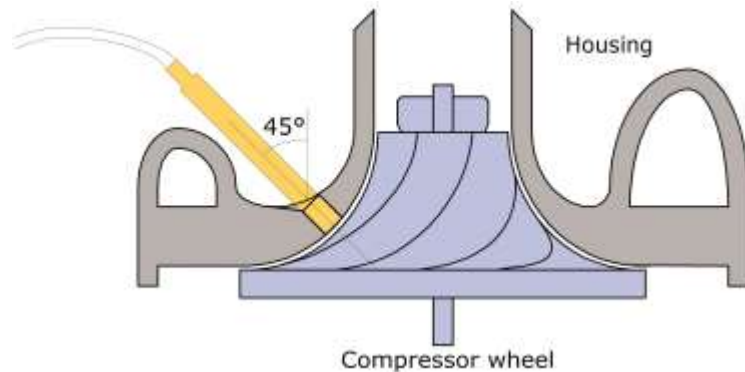

### NOTICE

The correct mounting position and method depends on the individual geometry and characteristics of the turbocharger in use. Contact the manufacturer of the turbocharger for information about details on possible positions and correct mounting instructions.

### NOTICE

**IMPORTANT:** Make sure the tip of the sensor is approximately flush with the inside contour of the housing. Otherwise, it may hit and damage the compressor wheel.

### NOTICE

**Lock torque:** The sensor body is not a 5-millimeter bolt, but merely a sleeve with some 0.3 mm thick walls. Apply only a fraction of the torque you would with a solid bolt: 0.3 Nm maximum (finger force, not fist force).

**Environment:** The sensor element with respect to its electronics and “superseal” connector has been designed for under-hood operation and is considered engine compartment tolerant.

## 6 Technical Data

Table 1: Sensor tip to compressor vane distance



Maximum distance sensor-vanes	Passenger cars	Commercial vehicles
Typical for aluminum wheels	1 to 2 mm	2 to 3 mm
The maximum distance depends strongly on the turbocharger geometry, the vane thickness at the sensor tip, the alloy of the wheel. So only an indication can be given.		

These are approximate values for aluminium compressor wheels. Exact values depend on turbocharger geometry.

Table 2: Other operating conditions

Supply voltage (box)	9 to 36 V		
Consumption (box)	-BX (RS232 option)	36 mA @24 V + 20 mA**	
	-BD (display option)	59 mA @24 V + 20 mA**	
Temperature (box)	-40 °C to +85 °C (-40 °F to +185 °F)		
Dimensions (box)	105 mm x 85 mm x 30 mm		
Temperature (sensor element)	Cable and electronics	-40 °C to +125 °C (+257 °F)	
	Sensor tip	SM types	-40 °C to +230 °C (+446 °F)
		H-SM types	-40 °C to +250 °C (+446 °F) +270°C (+518 °F) for 5 minutes
Dimensions (sensor body)	Fine thread M5 x 0.5 With various lengths 25 mm to 60 mm		
	Standard thread M5 x 0.8 With various lengths 40 mm to 60 mm		
Length of sensor element and cable	From sensor tip to ASIC	Approximately 0.75 meter	
	From ASIC to "Suprseal"	Approximately 0.12 meter	
	Total length	Approximately 1.00 meter	

\*\* Sensor

Table 3: Electrical operating conditions for the sensor elements PT2G-SM..

Supply voltage	+5 V DC ± 0.25 V, from linear voltage regulator
Consumption	20 mA

Table 4: Signal output and metrological characteristics

Interface	Specification	Remarks		
Analog-output (voltage)	Analog voltage 0.5 to 4.5 volts 0.5 volts = stand still 4.5 volts = 320,000 r.p.m. subject to correct vane number setting	The output is set parallel between the BNC connector and the M12 combi connector		
		Range	0.5 to 4.5 V	
		Slope	80,000 r.p.m./V (subject to correct vane number setting)	
		Measurement rate	Approximately 260 Hz	
		Resolution	390 r.p.m. when set to 10 vanes	
		Precision	0.25 % of full scale	
Digital- output (puls-es)	CMOS 5V / 10 mA one impulse per revolution subject to correct vane number setting	The output is set parallel between the BNC connector and the M12 combi connector		
		Minimum speed	Approximately 390 r.p.m.	
		Maximum speed	Approximately 400,000 r.p.m.	
		Precision	Approximately 390 r.p.m.	
Numeric output in ASCII over RS-232	Transfer rate 38400 baud, 8 bits, no parity, 1 stop bit („8N1“)	Unidirectional interface, for measurement result output only. May be read with any port monitor including freeware (e.g. Putty.exe). Output format:		
		<table border="1"> <tr> <td>Time stamp</td> <td>&lt;Space&gt;</td> <td>Measured value</td> <td>&lt;CR&gt;&lt;LF&gt;</td> </tr> </table> <p>Subject to correct vane number setting, the output reads revolutions per minute. The time stamp is in multiples of T = 3.84 ms. / Other: see Analog and Digital above.</p>	Time stamp	<Space>
Time stamp	<Space>	Measured value	<CR><LF>	

Charging an interface with current may cause the box to consume more than nominal value.

### 6.1 Vane number

On the front of the case there is a rotational code switch. This is to be used to set the number of vanes. Placing an inside jumper, the range is shifted from 2 to 15 to 16 to 31. To do this open the case. The place for the jumper is shown on the right.

Table 5: Number-of-vanes setting

Code switch	0	1	2	3	4	5	6	7	8	9	A	B	C	D	E	F
Without jumper	Place	n. c.	2	3	4	5	6	7	8	9	10	11	12	13	14	15
With jumper	16	17	18	19	20	21	22	23	24	25	26	27	28	29	30	31

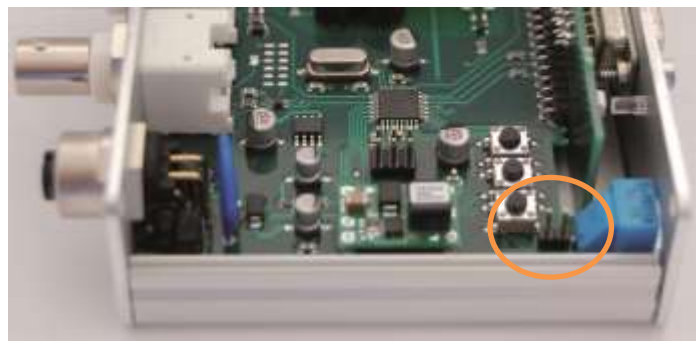

### 6.2 Diagnostics

Table 6: Diagnostics light emitting diode

Mode	LED color	Sensor element connected?	Turbocharger state	Meaning
Measurement mode	Black	No	Indifferent	Supply or box not ok
		Yes	Idle	Sensor element ok <sup>1</sup>
		Yes	Spinning <sup>2</sup>	Distance too big <sup>1</sup>
	Red <sup>3</sup>	No	Indifferent	Supply & box ok
	Red <sup>3</sup>	Yes	Indifferent	Sensor element defective
Place mode	Green	Yes	Spinning <sup>2</sup>	Whole chain ok
	Red <sup>3</sup>	Yes	Spinning <sup>2</sup>	Signal too weak / noisy
	Green	Yes	Spinning <sup>2</sup>	Distance & signal ok

<sup>1</sup> Provided, the LED turns red upon disconnecting the sensor

<sup>2</sup> To get the compressor wheel spinning, drive it with compressed air. The speed and the sense of the rotation are indifferent.

<sup>3</sup> Disrupt the supply from time to time, as the system may freeze in the "LED red" state.

**6.3 Sensors, Mechanical Dimension**

Table 7: Sensor head dimensions

PT2G-SM5.3	
PT2G-SM5.5	
PT2G-SM5.6	
PT2G-SM5F.2	
PT2G-SM5F.3	
PT2G-SM5F.5	

## 6.4 Technical Data for Specialists

Table 8: Pin assignment 3-pole "Superseal"

Pin	Pin name	Explanation
1	VCC	Supply voltage 5V DC
2	Signal	5V CMOS level, 4 mA max. The signal is square and symmetric. Every rising edge and every falling edge symbolizes one vane, leading to a half frequency pulse as compared to the vane appearance frequency
3	GND	Common ground for supply and signal

The PT2G sensors digital output toggles with each vane. In other words, the frequency is half the frequency of vanes. So please take care in case you use your own data logger and not the PT2G-Bx signal conditioning box. Please set only half the frequency or half the number of vanes to get the correct frequency.

**Note:** A good low-noise power supply is necessary for correct indication of zero speed. A more stringent specification is difficult to define and is not available at present. Generally speaking, linear voltage regulators are satisfactory, switching regulators are not.

Table 9: Pin assignment M12-thread combination connector 5-pole

Pin	Pin name	Explanation
1	GND	This is the supply ground, connected to the aluminum box.
2	Signal-GND	Signal ground, separated from supply ground.
3	Analog-Out (Voltage)	0.5 V to 4.5 V
4	VCC	Supply voltage 9 to 36 volts DC
5	Digital-Out (Pulses)	5 V CMOS,

## 7 Calibration

### 7.1 PICOTURN-CT (“PTCT”)

This device is for testing and calibrating the PT2G-BX and PT2G-BD signal conditioning boxes. It simulates the behavior of a sensor mounted to a turbocharger. A selectable vane frequency (revolution speed) is reproduced very precisely and allows the verification and calibration of the analog and digital output signals over the entire measurement range.

**PTCT front**



The number of vanes on a virtual compressor wheel and its simulated revolution speed are selected by push-button code switches

- Up to 32 vanes
  
- Revolution speeds between 0 and 360,000 rpm in steps of 40,000.

**PICOTURN-CT back + PT2G-X-CT cable**



The calibration unit itself is not measuring revolution speeds and can only be operated in conjunction with a PT2G-Bx device.

### 7.2 Technical Data

Table 10: Technical data

Supply voltage (box)	9 to 16 V	
Consumption (box)	20 mA @12 V	
Temperature (box)	-40 °C to +85°C (-40°F to +185 °F)	
Dimensions (box)	105 mm x 85 mm x 30 mm	
Length of PT2G-X-CT cable, connecting CT and PT2G-XS cable	From SMB to Superseal	Approximately 0.60 meters

### 7.3 Setup

In order to get started the following steps are necessary:

- Connect PT2G-Bx device under test to a 12 V DC power supply (battery, stationary power supply) by means of the PT2G-C-2B power supply cable. Connect the positive pole to the red connector, and the negative pole to the black connector. Connect the PTCT to the same power supply.
- Connect the PT2G-B... by means of the PT2G-X-CT cable and one of the extension cables PT2G-XS-O... to the PTCT.
- Connect the analog output to a calibrated, precision multimeter to measure the output voltage.
- Connect the digital output to a calibrated, precision frequency counter.

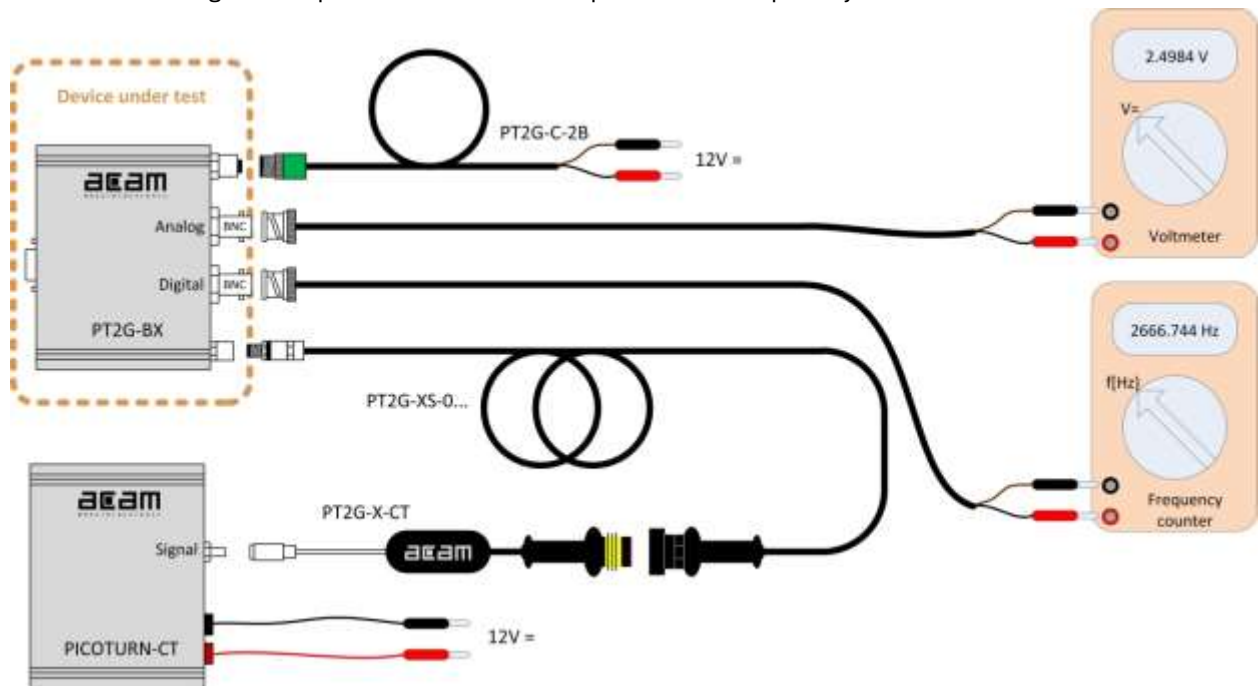

### 7.4 Calibration process

For calibration the box needs to be opened. Inside, there are 3 press buttons, labeled "+", "S", and "-".

1. Press "S" button until the LED blinks in green color (about 3 seconds).
2. Adjust the lower voltage by means of buttons "+" and "-". The analog voltage should be as close to 0.5V as possible.
3. Press "S" again to confirm the new setting. Now the LED blinks in red color.



4. Adjust the upper voltage at simulated 280,000 rpm by means of buttons “+” and “-”. The analog voltage should be as close to 4.0V as possible.
5. Press “S” again to confirm the new setting.

## 7.5 Verification

The verification is done in two steps. First, the number of vanes is set to a fixed value and only the speed setting is changed. Second, the speed is set to a fixed value and the vane number is changed.

### 7.5.1 Fixed Vane Number

The number of vanes is set to a fixed value, namely 10, on both PT2G-Bx and PTCT. On the PT2G rotational encoder “A” stands for 10.

In the following the setting for speed is increased from 0 to 8 by means of the push buttons and the values for output voltage and frequency are recorded, entered to the report and compared with the target values. The report is available as ready-made Excel sheet from acam at no charge.

The tolerable deviation is: Voltage +/- 0.5 % of full scale  
 Frequency +/- 0.009 % of full scale

Table 11: Calibration run with fixed vane number

Speed setting	Nominal speed 1/min	Voltage			Frequency			Status
		actual volts	nominal volts	error % F.S.	actual Hz	nominal Hz	error % F.S.	
0	0	0,5023	0,5000	0,05	0,000	0,000	0,000	ok
1	40000	0,9998	1,0000	0,00	666,685	666,667	0,000	ok
2	80000	1,4977	1,5000	-0,05	1333,373	1333,333	0,001	ok
3	120000	2,0003	2,0000	0,01	2000,056	2000,000	0,001	ok
4	160000	2,4984	2,5000	-0,04	2666,744	2666,667	0,001	ok
5	200000	3,0017	3,0000	0,04	3333,429	3333,333	0,002	ok
6	240000	3,4997	3,5000	-0,01	4000,106	4000,000	0,002	ok
7	280000	4,0027	4,0000	0,06	4667,572	4667,445	0,002	ok
8	320000	4,5009	4,5000	0,02	5333,408	5333,333	0,001	ok

### 7.5.2 Calibration run with fixed nominal speed

On the PTCT the number of vanes has to be set to 4 and the speed has to be set to 7. This corresponds to a pulse frequency of 18,665.42 Hz. The number of vane setting on the PT2G-B... box is variable. It is changed from 4\* to 15, and again the values for output voltage and frequency are recorded, entered to the report and compared with the target values.

Table 12: Calibration run with fixed speed



No. of vanes setting	Nominal speed 1/min	Voltage			Frequency			Sta- tus
		actual	nominal	error	actual	nominal	error	
		volts	volts	% F.S.	Hz	Hz	% F.S.	
4	279981	4,0006	4,000	0,019	4666,49	4666,355	0,001	ok
5	223985	3,3026	3,300	0,061	3733,17	3733,084	0,000	ok
6	186654	2,8354	2,833	0,049	3110,99	3110,903	0,000	ok
7	159989	2,4994	2,500	-0,011	2666,56	2666,489	0,000	ok
8	139991	2,2490	2,250	-0,019	2333,25	2333,178	0,000	ok
9	124436	2,0561	2,055	0,015	2073,98	2073,936	0,000	ok
10	111993	1,9018	1,900	0,042	1866,60	1866,542	0,000	ok
11	101811	1,7719	1,773	-0,016	1696,91	1696,856	0,000	ok
12	93327	1,6659	1,667	-0,015	1555,50	1555,452	0,000	ok
13	86148	1,5759	1,577	-0,020	1435,85	1435,802	0,000	ok
14	79995	1,4989	1,500	-0,022	1333,28	1333,244	0,000	ok
15	74662	1,4349	1,433	0,037	1244,40	1244,361	0,000	ok

\* Settings 2 and 3 will give a good frequency output but the analog out will be at 5V

**Note:** The maximum vane frequency (vanes per second) that can be simulated is 100 kHz. If this frequency is exceeded due to "speed" and "no. of vanes" setting, the calibration device automatically goes back to standstill. Choosing parameters out of range (e.g. no. of vanes < 4 or > 32) provokes standstill simulation, too.



## 8 Miscellaneous

### 8.1 Last Changes

- 07.11.2008 German original
- 03.02.2009 Complete revision
- 05.03.2009 Native speaker editing
- 05.09.2009 Re-layout
- 08.03.2010 Complete revision, release 1.1
- 16.10.2010 Small corrections in release 1.1
- 02.09.2011 Release 1.3, ATI product added
- 22.11.2011 Release 1.4; product list updated, tables 2 and 5 amended
- 03.01.2012 Section 1 (product list) corrected
- 08.08.2014 Calibration added, general revision, adding also warnings



The products **PICOTURN** comply with EMC Directive 89/336/EEC, applied standard DIN EN 61326, Equipment for Control and Laboratory (for use in electromagnetically controlled environment).

Generic immunity standard part 2 (EN 61000-4-4: 0,5KV, -4-6: 1V), In case of strong electromagnetic disturbances there might be a deviation of the output signal from the specification, but only for the duration of the disturbance.



acam®, **PICOTURN**® are registered trademarks of acam-messelectronic gmbh.

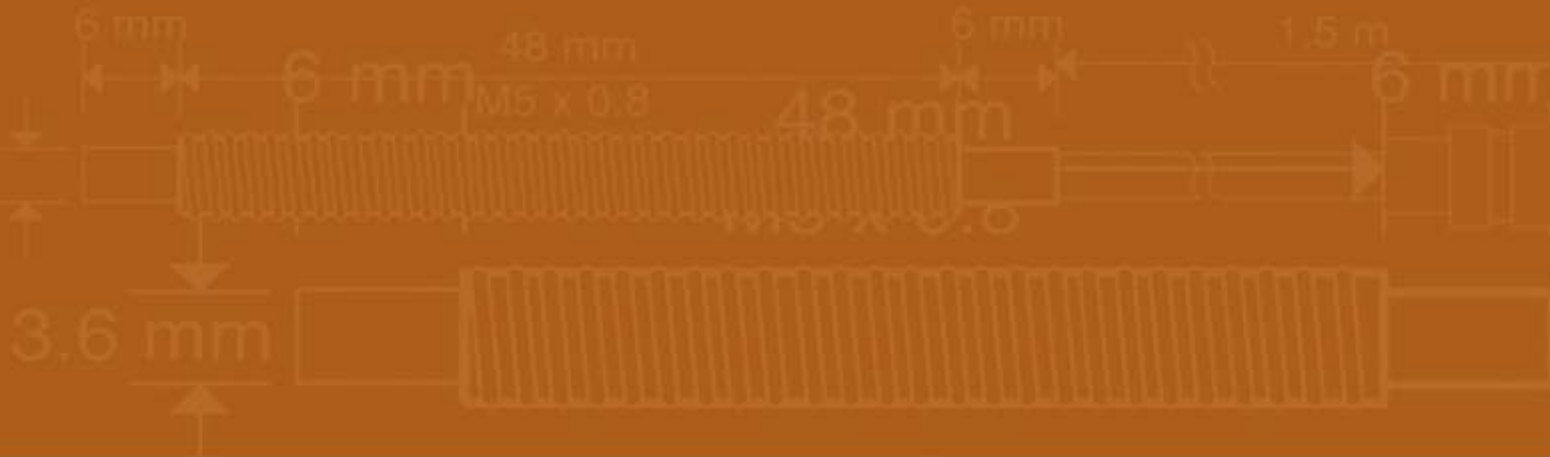

acam-messelectronic gmbh  
Friedrich-List-Straße 4  
76297 Stutensee-Blankenloch  
Germany  
Phone +49 7244 7419 - 0  
Fax +49 7244 7419 - 29  
E-Mail [support@acam.de](mailto:support@acam.de)  
[www.acam.de](http://www.acam.de)