



Sirius



Features

- Motion control system provides increased labelling accuracy coupled with absolute speed matching to cope with variable speed demands of today's packaging lines.
- Enhanced control system incorporating single touch-screen user interface provides a very high level of user diagnostics. The unique software enables quick set-up times between product changeover and is self-monitoring to provide optimum reliability. This reduces the skill level required for operation and maintenance.
- Increased cabinet space allows for greater flexibility for future upgrades.
- Fully integrated inspection systems to identify label and/or overprint presence; barcode readability is available and easily incorporated. Also available is the integration of a vision system capable of identifying label position on the product plus the correct lot/expiration data.
- Modularized transmission system utilizing the latest technology ensures that the Sirius provides the optimum level of flexibility and reliability for all current and future labelling requirements.
- These next generation of 'Harland Sirius' features are also incorporated in the Tamper Evident (TE), Twin Side Belt (TSB), Top/Bottom and Vertical Roller Stabilizer (VRS) labellers.

Sirius Self-Adhesive Labelling System

Cost-effective, versatile, user-friendly, no changepart labeling system

The incorporation of the very latest in control technology, enables 'Sirius' to handle a wide variety of product and label shapes making it the most versatile, user-friendly, efficient and highly accurate labelling system.

Packed with the latest technology for even greater production line benefits. 'Sirius' has been designed to meet the most stringent GMP requirements as well as addressing MTBF (Mean Time Between Failure) and MTTR (Mean Time To Repair) needs.

Technical Specifications

- Base Unit: Stainless steel unit, available with 1 or 2 label stations.
- Infeed Unit: Single scroll, twin scroll, infeed wheel, orientation units for aligning ovals.
- Label Head: Label head speed up to 28.5 m/min. Stepper motor driven motion controlled.
- Stabilizer: Horizontally mounted 935 mm long servo driven unit.
- Conveyor: 2438 mm long, 82.5 mm Delryn slatband.
- Finishing Units: Non-driven and driven wipedown rollers, wraparound unit, walking beam.
- Overprint Unit: Hot foil, deboss, thermal transfer, inkjet and laser coders.
- Ancillary Equipment: A wide range is available including - product and label counters, infeed/outfeed monitoring controls and pharmaceutical security systems.
- Capacities: As standard.

Production Rates	Up to 300 products per minute depending on product and label sizes.
Electrical Requirements	220V/240 V single phase AC, 50/60 Hz. Special electrical options available on request.
Air Requirements	Air required for some overprinters and security systems.
Weight	As standard 320 kg
Product Capacity	Maximum Diameter: 100 mm Maximum Height: 350 mm Minimum Height: 20 mm Maximum Width: 200 mm Minimum Width: 15 mm
Label Capacity	Maximum Web Width: 155 mm Minimum Web Width: 13 mm Maximum Label Length: 330 mm Minimum Label Length: 10 mm

**All specification and tooling requirements are subject to Accraply evaluation of all label and product samples. Specifications shown reflect standard machine capabilities. Accraply can also meet other specification requirements. Please call for details.*

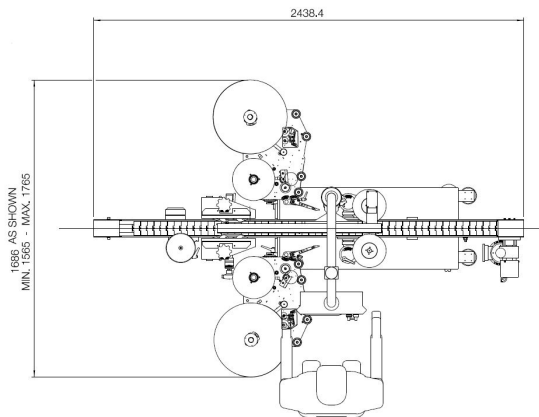

Plan View (All dimensions in mm)

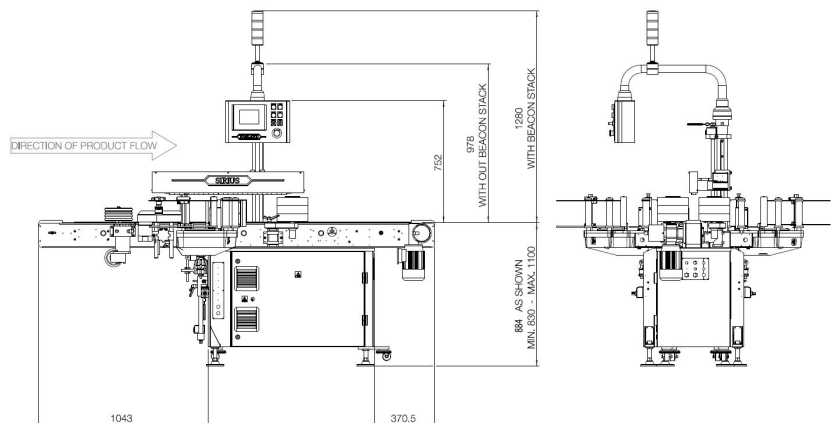

Front View (All dimensions in mm)

Accraply

Trine

Stanford

Graham | Sleeveit

Harland

Accraply

3580 Holly Lane North
Plymouth MN 55447-1269 USA

t. +1 (763) 557-1313
accraply.com

