

LIMITED WARRANTY

THIS MODEL E-01 EMERGENCY LOCATOR TRANSMITTER IS GUARANTEED BY ACK TECHNOLOGIES INC. AGAINST DEFECTS IN MATERIALS AND WORKMANSHIP FOR A PERIOD OF TWO YEARS FROM DATE OF PURCHASE OR TWO YEARS AND SIX MONTHS FROM DATE IT WAS MANUFACTURED. THIS WARRANTY IS VOID UNLESS THE ENCLOSED WARRANTY CARD HAS BEEN COMPLETED AND RETURNED TO ACK TECHNOLOGIES INC. WITHIN 15 DAYS OF ITS INSTALLATION. THIS WARRANTY IS LIMITED EXCLUSIVELY TO REPAIR OR REPLACEMENT OF THE E-01 ELT AND ASSOCIATED PARTS WHICH WERE MANUFACTURED BY ACK TECHNOLOGIES INC. THE DEFECTIVE PARTS MUST BE RETURNED FREIGHT PREPAID TO OUR MANUFACTURING FACILITY. THIS WARRANTY DOES NOT INCLUDE REPAIR OR REPLACEMENT OF ANY PART WHICH HAS BEEN IMPROPERLY USED, INSTALLED OR PHYSICALLY DAMAGED. THIS WARRANTY DOES NOT INCLUDE ANY DAMAGE CAUSED BY THE LEAKAGE OF BATTERIES. EXCEPT AS PROVIDED HEREIN ACK TECHNOLOGIES INC. MAKES NO EXPRESS WARRANTIES, AND ANY IMPLIED WARRANTY OF MERCHANTABILITY OF FITNESS FOR A PARTICULAR PURPOSE IS LIMITED IN ITS DURATION TO THE DURATION OF THE WRITTEN LIMITED WARRANTIES SET FORTH HEREIN. ACK TECHNOLOGIES INC. SHALL NOT BE LIABLE FOR ANY DIRECT, INDIRECT, SPECIAL OR CONSEQUENTIAL DAMAGES ARISING OUT OF THE USE OR MISUSE OF THIS PRODUCT. EXCEPT AS PROVIDED HEREIN NO EMPLOYEE, AGENT, DEALER OR OTHER PERSON IS AUTHORIZED TO GIVE ANY WARRANTIES OF ANY NATURE ON BEHALF OF ACK TECHNOLOGIES INC.

YOU MAY HAVE ADDITIONAL LEGAL RIGHTS WHICH VARY FROM STATE TO STATE

**ACK TECHNOLOGIES
INC.**

440 WEST JULIAN ST.
SAN JOSE, CA 95110
WWW.ACKAVIONICS.COM

PHONE (408) 287-8021

FAX (408) 971-6879

E-MAIL INFO@ACKAVIONICS.COM

**ACK TECHNOLOGIES
INC.**

MODEL E-01 ELT INSTALLATION MANUAL OPERATION MANUAL

The conditions and test required for TSO authorization of this article are minimum performance standards. It is the responsibility of those desiring to install the article either on or within a specific type or class of aircraft to determine that the aircraft installation conditions are within the TSO standards. The article may be installed only when further evaluation by the applicant documents an acceptable installation and is approved by the Administrator.

Visit our website www.ackavionics.com for the latest service bulletins and installation information before completing installation.



IMPORTANT

WHEN INSTALLING DURACELL BATTERIES WITH POWER TEST STRIPS SEE PAGE 2 PARAGRAPH 3 AND FIG. 3 THE BOTTOM BATTERIES ARE DESIGNED TO BE A TIGHT FIT IN THE CASE. APPLY A LIGHT COAT OF AUTOMOTIVE PASTE WAX TO THE CELLS TO FACILITATE INSTALLATION. PLACE ALL FOUR LOWER CELLS IN THEIR PROPER POSITION AT THE TOP OF THE CASE AND PUSH INTO POSITION ALL AT THE SAME TIME.

REV. DATE 09/04/2007

TABLE OF CONTENTS

- SECTION 1 BATTERY INSTALLATION AND REPLACEMENT
- SECTION 2 ELT INSTALLATION
- SECTION 3 ANTENNA INSTALLATION
- SECTION 4 REMOTE MONITOR INSTALLATION
- SECTION 5 FINAL INSTALLATION
- SECTION 6 HELICOPTER INSTALLATIONS
- SECTION 7 PERIODIC MAINTENANCE
- SECTION 8 OPERATION
- SECTION 9 SPECIFICATIONS

SECTION 1 TRANSMITTER BATTERY REPLACEMENT

THE ACK MODEL E-01 ELT IS DESIGNED TO USE ONLY DURACELL, MN1300, MX1300 OR PC1300 ALKALINE BATTERIES WHICH ARE DATED BY THE MANUFACTURER. NO BATTERIES ARE SUPPLIED WITH THE ELT.

THE USE OF ANY OTHER BATTERY WILL VOID ANY WARRANTIES OF THE ELT BY ACK TECHNOLOGIES, INC.

THE ELT DOES NOT MEET THE REQUIREMENTS OF TSO-91a OR FAR 91.207 IF USED WITH ANY OTHER TYPE OF BATTERY.

BATTERY REPLACEMENT IS REQUIRED UPON REACHING THE DATE MARKED UPON EACH CELL. ALL CELLS MUST BE REPLACED AT THE SAME TIME AND ALL CELLS MUST HAVE THE SAME EXPIRATION DATE.

FAR 91.207 (c)(1) REQUIRES THAT BATTERIES BE REPLACED WHEN THE TRANSMITTER HAS BEEN IN USE FOR MORE THAN ONE CUMULATIVE HOUR.

THE EXPIRATION DATE OF THE BATTERIES MUST BE INDICATED ON THE OUTSIDE OF THE ELT BATTERY CASE AND RECORDED IN THE AIRCRAFT LOGS. ADHESIVE LABELS ARE PROVIDED TO RECORD THIS INFORMATION.

BATTERY REPLACEMENT MAY BE PERFORMED BY THE OWNER OR OPERATOR PROVIDED THE ACCESSIBILITY, REMOVAL AND REINSTALLATION OF THE ELT CAN BE CONSIDERED "SIMPLE" AS PRESCRIBED IN ADVISORY CIRCULAR 91-44A, PARAGRAPH 8.a. (SEE APPENDIX B PAGE 16)

FOLLOWING ARE STEP BY STEP INSTRUCTIONS FOR REPLACING THE ELT BATTERIES (SEE SERVICE BULLETIN SB E-01.6)

1. USING THE 3/32" HEX DRIVER SUPPLIED WITH THE ELT, REMOVE THE 4 RETAINING SCREWS AND SPLIT LOCK WASHERS WHICH ATTACH THE BATTERY CASE TO THE ELT TRANSMITTER ASSEMBLY (FIGURE 1). **CAUTION DO NOT REMOVE THE FRONT SCREWS FROM THE TRANSMITTER ASSEMBLY.** IF THE ELT CONTAINS BATTERIES LOOSEN THE SCREWS EVENLY A FEW TURNS AT A TIME UNTIL THE BATTERY CONTACT SPRING PRESSURE IS RELIEVED.

2. REMOVE BATTERIES FROM THE BATTERY CASE. THE FOUR BATTERIES WHICH FIT IN THE BOTTOM OF THE BATTERY CASE ARE DESIGNED TO BE A SNUG FIT. IT MAY BE NECESSARY TO TAP THE OPEN END OF THE BATTERY CASE ON A FLAT SURFACE TO DISLodge THESE BOTTOM BATTERIES. MAKE SURE THE EXPIRED BATTERIES ARE EITHER DISCARDED OR REMOVED FROM THE WORK AREA BEFORE CONTINUING TO STEP NUMBER 3. EXAMINE THE BATTERY CONTACTS, ANY DIRT OR CORROSION SHOULD BE GENTLY REMOVED USING A ELECTRICAL CONTACT CLEANER AND A STIFF BRUSH.

DO NOT USE ABRASIVE CLEANERS OR MATERIALS TO CLEAN THE CONTACTS. THE CONTACTS ARE NICKEL AND GOLD PLATED SPRING STEEL. ABRASIVE MATERIAL WILL REMOVE THIS PLATING. IF THE CONTACTS APPEAR TO BE BADLY CORRODED THEY MUST BE REPLACED.

3. RECORD THE BATTERY REPLACEMENT DATE OF THE NEW CELLS BEING INSTALLED USING ONE OF THE ADHESIVE LABELS PROVIDED WITH THE ELT. THE BATTERY REPLACEMENT DATE IS FOUND ON EACH DURACELL® MN1300 CELL. (FIGURE 2) IT READS AS FOLLOWS: "BEST IF INSTALLED BY (DATE)". THE "(DATE)" INDICATED IS THE DATE BY WHICH THE BATTERIES MUST BE REPLACED. ALL CELLS MUST HAVE THE SAME DATE. INSTALL THE NEW BATTERIES AS INDICATED BY THE BATTERY INSTALLATION PLACARDS WHICH ARE AFFIXED TO THE INSIDE OF THE BATTERY CASE. IMPORTANT WHEN INSTALLING THE NEW STYLE DURACELL BATTERIES WHICH HAVE A BUILT IN TEST STRIP ON THE SIDE OF THE CELL, THESE TEST STRIPS MUST BE ORIENTED SO THAT THE TEST STRIP DOES NOT CONTACT THE PLASTIC CASE OR ANY OTHER CELL (SEE FIGURE 3)

4. AFTER INSTALLATION A VOLTAGE AND POLARITY CHECK MUST BE PERFORMED TO INSURE THAT THE BATTERIES HAVE BEEN INSTALLED CORRECTLY. (FIGURE 3)

5. AFTER PERFORMING THE ABOVE VOLTAGE CHECK INSTALL THE BATTERY CASE TO THE TRANSMITTER ASSEMBLY MAKING SURE THAT THE BATTERY CASE INDEX PIN HOLE IS ALIGNED WITH THE INDEX PIN OF THE TRANSMITTER ASSEMBLY AND THE O RING SEAL IS IN PLACE. (FIGURE 4)

6. PLACE THE TRANSMITTER ASSEMBLY FACE DOWN ON A BENCH WITH THE MODULAR CONNECTOR CABLE JUST PAST THE EDGE. PRESS DOWN ON THE BATTERY CASE TO COMPRESS THE BATTERY CONTACT SPRINGS REPLACE THE FOUR BATTERY RETAINING SCREWS AND LOCK WASHERS AND EVENLY TIGHTEN UNTIL THE BATTERY CASE IS PULLED FLAT AGAINST THE TRANSMITTER ASSEMBLY. IF THE O RING APPEARS TO BE PINCHED BETWEEN THE CASE AND TRANSMITTER, BACK-OFF THE SCREWS SLIGHTLY AND PUSH THE O RING BACK INTO PLACE WITH A THIN SCREWDRIVER OR PIECE OF SHEET METAL. SLIGHTLY WETTING THE O RING BEFORE ASSEMBLY GREATLY HELPS THIS ASSEMBLY.

8. REMOVE ANY EXISTING BATTERY REPLACEMENT DATE LABELS FROM THE BATTERY CASE AND INSTALL THE NEW LABEL YOU PREPARED IN STEP 3 ABOVE IN A READILY VISIBLE LOCATION ON THE ELT.

7. AFTER BATTERY REPLACEMENT A TRANSMITTER FUNCTION TEST MUST BE PERFORMED AS DESCRIBED IN SECTION 5 OF THIS MANUAL.

8. INITIAL BATTERY INSTALLATION AND REPLACEMENT PROCEDURES FOR THE REMOTE CONTROL PANEL/INDICATOR (RCPI) ARE DESCRIBED IN SECTION 4 OF THIS MANUAL.

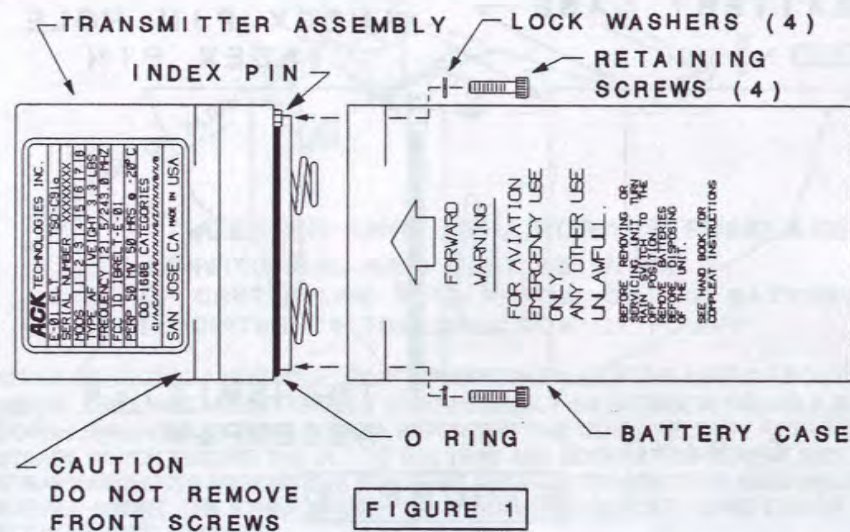

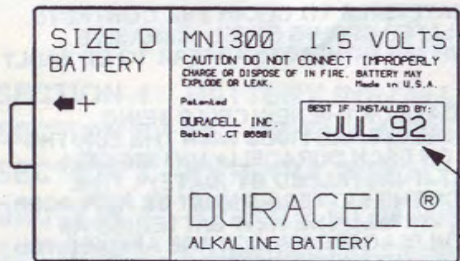

FIGURE 2

DATE

POLARITY RELATIVE TO INDEX PIN HOLE VOLTAGE MUST MEASURE ABOVE 6.0 VOLTS

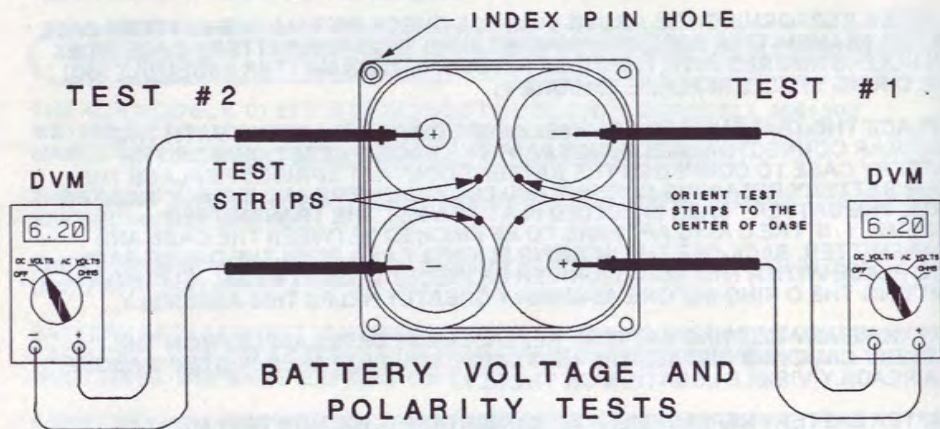

FIGURE 3

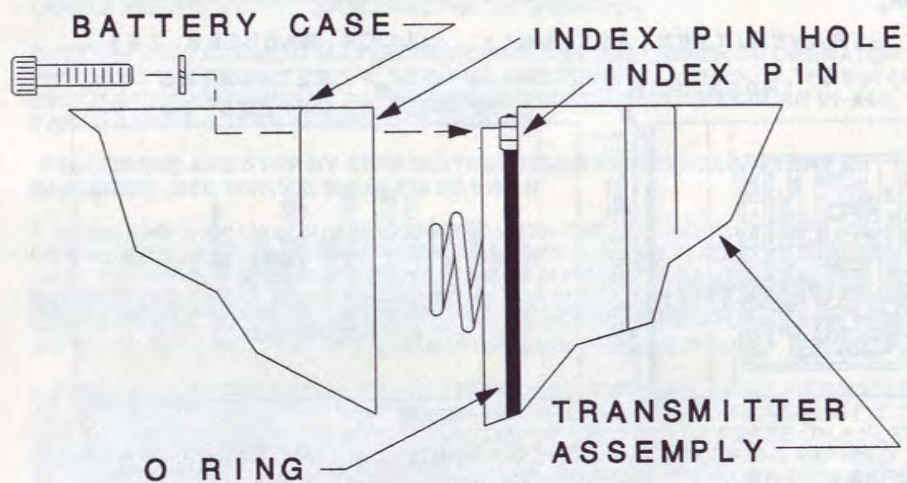

FIGURE 4

SECTION 2 ELT INSTALLATION

MANY OF THE PROBLEMS ASSOCIATED WITH FIRST GENERATION ELT'S (TSO-C91) WERE THE RESULT OF POORLY CHOSEN MOUNTING LOCATIONS. GENERALLY THE MOST SUITABLE LOCATION FOR FIXED WING AIRCRAFT IS TO POSITION THE ELT TRANSMITTER IN THE AIRCRAFT FUSELAGE AS FAR AFT AS POSSIBLE. ANTENNA LOCATION, ACCESSIBILITY FOR MAINTENANCE OR PORTABLE OPERATION, ARE FACTORS WHICH SHOULD BE TAKEN INTO CONSIDERATION WHEN CHOOSING A MOUNTING LOCATION. RTCA DOCUMENT DO-183 PARAGRAPH 3.1.8 PRESCRIBES THE MOUNTING REQUIREMENTS WHICH MUST BE MET WHEN INSTALLING THIS ELT. THESE REQUIREMENTS ARE AS FOLLOWS:

ELT MOUNTING

(DO-183 PARAGRAPH 3.1.8)

THE ELT SHALL BE MOUNTED TO PRIMARY AIRCRAFT LOAD-CARRYING STRUCTURES SUCH AS TRUSSES, BULKHEADS, LONGERONS, SPARS, OR FLOOR BEAMS (NOT AIRCRAFT SKIN). THE MOUNTS SHALL HAVE A MAXIMUM STATIC LOCAL DEFLECTION NO GREATER THAN 2.5mm (0.1 INCH) WHEN A FORCE OF 450 NEWTONS (100 LBS) IS APPLIED TO THE MOUNT IN THE MOST FLEXIBLE DIRECTION. DEFLECTION MEASUREMENTS SHALL BE MADE WITH REFERENCE TO ANOTHER PART OF THE AIRFRAME NOT LESS THAN 0.3 METER (1 FOOT) NOR MORE THAN 1.0 METER (3 FEET) FROM THE MOUNTING LOCATION.

THE ELT MUST BE MOUNTED WITH THE ARROW WHICH IS PRINTED ON THE BATTERY CASE POINTING IN THE DIRECTION OF FLIGHT. THE ELT SHOULD BE MOUNTED WITH IT'S LONGITUDINAL AXIS ALIGNED WITHIN 10° OF THE LONGITUDINAL AXIS OF THE AIRCRAFT FUSELAGE. AVOID MOUNTING THE ELT NEAR SOURCES OF STRONG EMI/RFI RADIATION. (FIGURE 5)

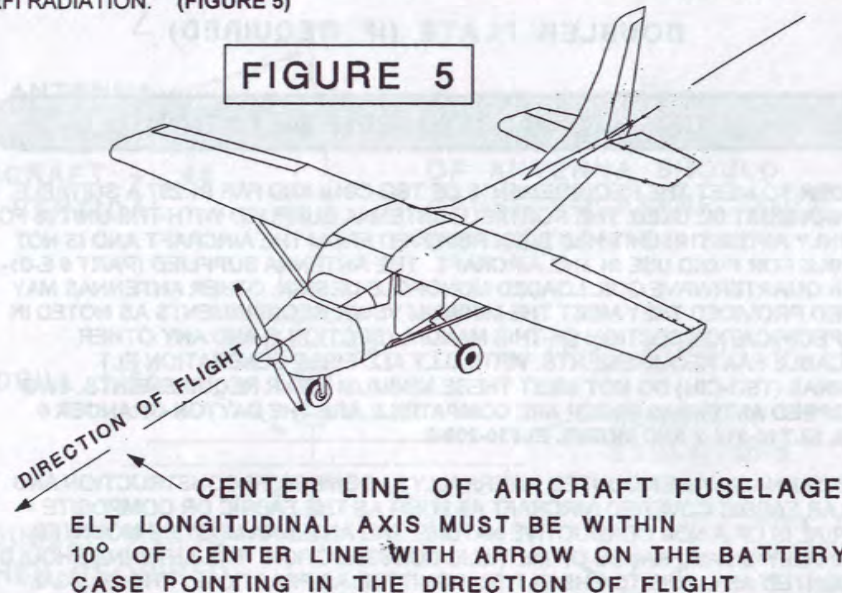
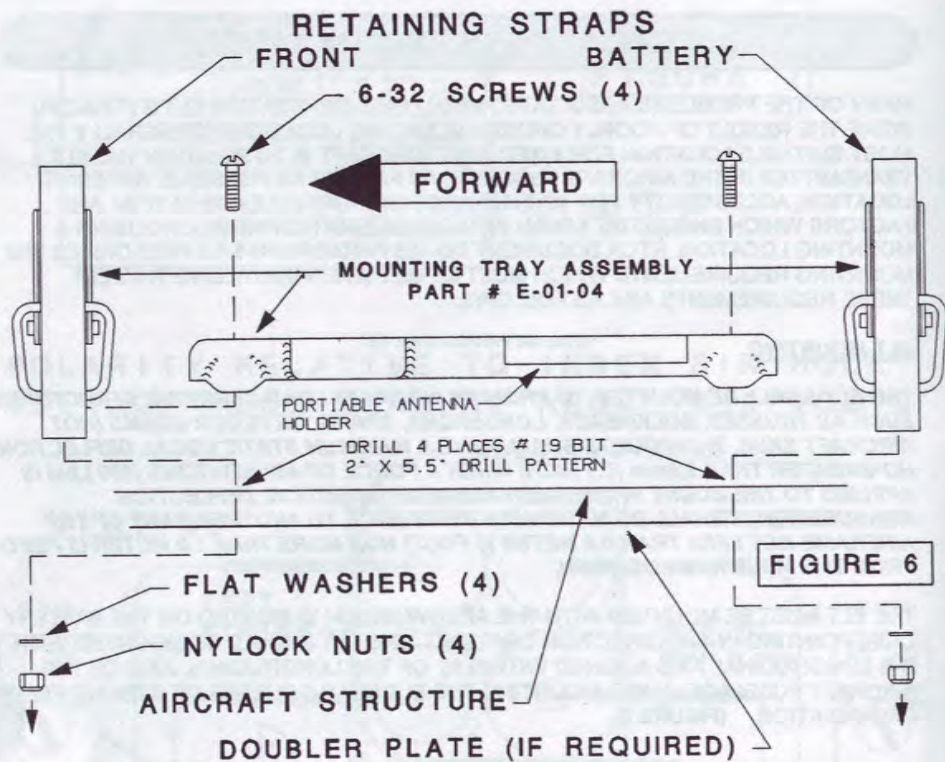

FIGURE 5

AFTER SELECTING A SUITABLE LOCATION MEETING ALL OF THE ABOVE REQUIREMENTS. DRILL AND MOUNT THE ELT TRAY ASSEMBLY AS SHOWN IN FIGURE 6. A DOUBLER PLATE MAY BE REQUIRED. IMPORTANT THE QUICK RELEASE RETAINING STRAPS WHICH SECURE THE ELT TO THE TRAY ARE SLIGHTLY DIFFERENT SIZE. THE STRAP WHICH FITS AROUND THE FRONT OF THE ELT (TRANSMITTER ASSEMBLY) IS MARKED FRONT. THE STRAP WHICH FITS AROUND THE BATTERY CASE END OF THE ELT IS MARKED BATTERY.



SECTION 3 ANTENNA INSTALLATION

IN ORDER TO MEET THE REQUIREMENTS OF TSO-C91a AND FAR 91.207 A SUITABLE ANTENNA **MUST BE USED**. THE PORTABLE ANTENNA SUPPLIED WITH THE UNIT IS FOR USE **ONLY** AFTER THE UNIT HAS BEEN REMOVED FROM THE AIRCRAFT AND IS NOT SUITABLE FOR FIXED USE IN THE AIRCRAFT. THE ANTENNA SUPPLIED (PART # E-01-15) IS A QUARTERWAVE COIL LOADED MONOPOLE DESIGN. OTHER ANTENNAS MAY BE USED PROVIDED THEY MEET THE MINIMUM VSWR REQUIREMENTS AS NOTED IN THE SPECIFICATION SECTION OF THIS MANUAL (SECTION 9) AND ANY OTHER APPLICABLE FAA REQUIREMENTS. **VIRTUALLY ALL FIRST GENERATION ELT ANTENNAS (TSO-C91) DO NOT MEET THESE MINIMUM VSWR REQUIREMENTS. TWO HIGH SPEED ANTENNAS WHICH ARE COMPATIBLE ARE THE DAYTON-GRANGER® MODEL ELT10-214-2 AND MODEL ELT10-209-2.**

THE ANTENNA MAY BE MOUNTED INTERNALLY IN COMPOSITE CONSTRUCTION AND TUBULAR FABRIC COVERED AIRCRAFT AS LONG AS THE FABRIC OR COMPOSITE MATERIAL IS OF A NON CONDUCTIVE NATURE. THE ANTENNA MUST BE MOUNTED EXTERNALLY ON AIRFRAMES OF METALLIC CONSTRUCTION. THE ANTENNA SHOULD BE MOUNTED AS CLOSE TO THE ELT TRANSMITTER AS PRACTICAL. THE COAXIAL CABLE CONNECTING THE ANTENNA TO THE ELT SHOULD NOT BE RUN IN CLOSE PROXIMITY TO COMM RADIO COAXIAL CABLES AND SHOULD AVOID CROSSING AIRCRAFT PRODUCTION BREAKS (i.e. RIVETED FUSELAGE SECTIONS). THE ANTENNA MUST BE WITHIN 45 DEGREES OF VERTICAL WHEN THE AIRCRAFT IS IN A NORMAL FLIGHT ATTITUDE. THE INSTALLED ANTENNA MUST BE ABLE TO WITHSTAND A STATIC LOAD OF 100 TIMES IT'S WEIGHT (12 Lbs) APPLIED TO THE BASE OF THE ANTENNA ALONG THE LONGITUDINAL AXIS OF THE AIRCRAFT. THE ANTENNA SHOULD BE PLACED A MINIMUM DISTANCE OF 5 FEET (1.6 METER) FROM ANY VERTICALLY

POLARIZED COMMUNICATION ANTENNAS (i.e. ANTENNAS RADIATING IN THE 118 - 137 Mhz BAND).

INSTALL THE ANTENNA AS FOLLOWS:

1. DRILL A 1/2" DIAMETER HOLE IN THE AIRCRAFT STRUCTURE AT THE ANTENNA MOUNTING LOCATION. (FIGURE 7)
2. INSTALL THE ANTENNA AND DETERMINE IF THE ANTENNA MEETS THE STATIC LOAD REQUIREMENTS. IF NOT A DOUBLER SHOULD BE FABRICATED. (FIGURE 7)
3. IF THE ANTENNA IS BEING MOUNTED ON A NON CONDUCTIVE PORTION OF THE AIRFRAME A SUPPLEMENTARY GROUND PLANE MUST BE INSTALLED. THE SUPPLEMENTAL GROUND PLANE MUST HAVE A MINIMUM DIAMETER OF 36" AND BE CENTERED ABOUT THE BASE OF THE ANTENNA. THIS MAY BE FABRICATED OUT OF COPPER OR ALUMINUM TAPE. THE TAPE SHOULD BE CUT INTO 6 ELEMENTS 18" LONG AND THE TAPE ELEMENTS SHOULD BE EVENLY SPACED RADIATING IN A CIRCULAR PATTERN FROM THE BASE MOUNTING POINT OF THE ANTENNA. MAKE SURE ALL ELEMENTS ARE ELECTRICALLY BONDED TO THE BASE OF THE ANTENNA. THE TAPE MAY FOLLOW THE CONTOUR OF THE FUSELAGE. THE METALLIC AIRFRAME OF FABRIC COVERED AIRCRAFT MAY BE USED AS THE GROUND PLANE. WHEN INSTALLING THE ANTENNA MAKE SURE THE BASE OF THE ANTENNA IS ELECTRICALLY BONDED TO THE TUBING AIRFRAME.
4. ASSEMBLE THE ANTENNA AS SHOWN IN FIGURE 7. MAKE SURE THE RUBBER WASHER WHICH FORMS A MOISTURE SEAL BETWEEN THE ANTENNA BASE AND AIRCRAFT STRUCTURE IS IN PLACE BEFORE INSTALLING THE ANTENNA. ALSO MAKE SURE THE SERRATED LOCKING WASHER IS IN PLACE.

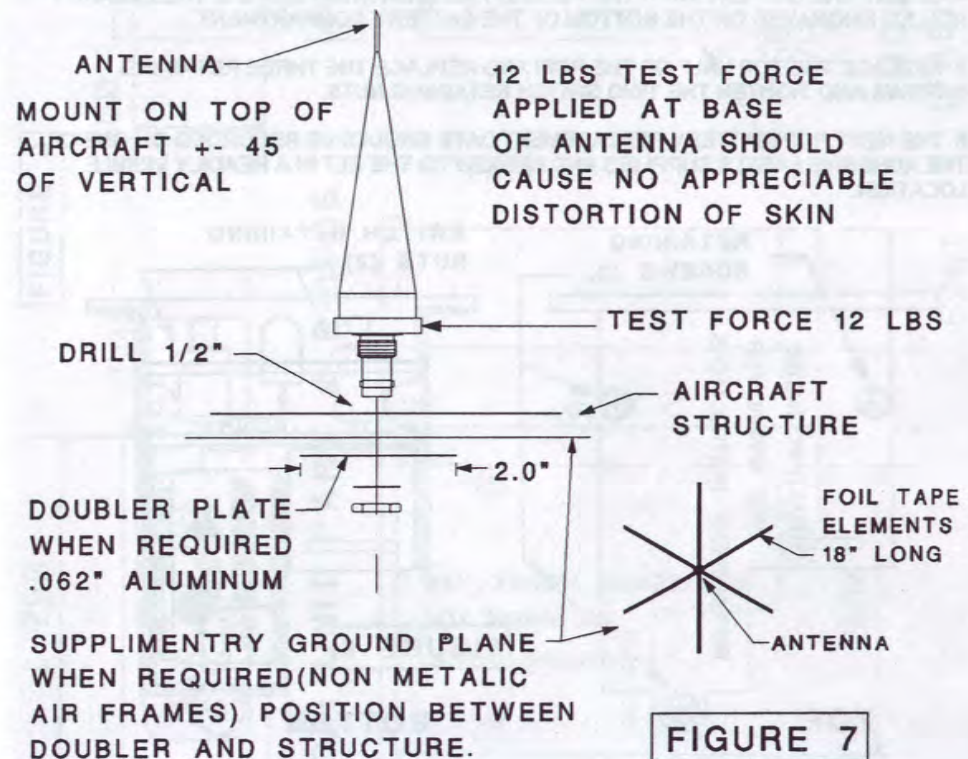

SECTION 4 REMOTE MONITOR INSTALLATION

IMPORTANT NO BATTERY IS SUPPLIED WITH RCPI UNIT

THE REMOTE CONTROL PANEL/INDICATOR (RCPI), PART NUMBER E-01-05, IS DESIGNED TO BE POWERED BY A SINGLE DURACELL®PX28L 6 VOLT LITHIUM BATTERY UNDER NORMAL OPERATING CONDITIONS THE LITHIUM BATTERY MUST BE REPLACED EVERY EIGHT YEARS. ALKALINE TYPE CELLS ARE AVAILABLE FROM VARIOUS MANUFACTURERS AND MAY BE USED IN PLACE OF THE LITHIUM CELL. UNDER NORMAL OPERATING CONDITIONS THE ALKALINE BATTERY MUST BE REPLACED EVERY FOUR YEARS. IF THE ELT IS ACTIVATED FOR AN UNKNOWN PERIOD OF TIME THE BATTERY, LITHIUM OR ALKALINE, MUST BE REPLACED. EQUIVALENT BATTERIES FROM OTHER MANUFACTURERS ARE ACCEPTABLE FOR USE IN THE RCPI UNIT.

TO INSTALL OR REPLACE THE RCPI BATTERY FOLLOW THESE STEPS:

1. REMOVE THE THREE RETAINING SCREWS WHICH SECURE THE TOP AND BOTTOM HALF OF THE RCPI UNIT. (FIGURE 8)
2. LOOSEN THE TWO SWITCH RETAINING NUTS LOCATED ON THE FRONT OF THE UNIT. (FIGURE 8)
3. CAREFULLY REMOVE THE TOP HALF OF THE RCPI UNIT EXPOSING THE BATTERY COMPARTMENT. (FIGURE 8) IF REPLACING AN OLD BATTERY CAREFULLY INSPECT THE BATTERY CONTACTS FOR DIRT OR CORROSION. IF THE CONTACTS NEED CLEANING USE ONLY NON ABRASIVE ELECTRICAL CONTACT CLEANER AND A STIFF BRUSH. ABRASIVE CLEANERS WILL REMOVE THE NICKEL AND GOLD PLATING FROM THE CONTACTS. BADLY CORRODED CONTACTS SHOULD BE REPLACED.
4. INSERT THE BATTERY WITH THE POLARITY AS SHOWN IN FIGURE 8. THE POLARITY IS ALSO ENGRAVED ON THE BOTTOM OF THE BATTERY COMPARTMENT.
5. REPLACE THE TOP HALF OF THE RCPI AND REPLACE THE THREE RETAINING SCREWS AND TIGHTEN THE TWO SWITCH RETAINING NUTS.
6. THE NEXT RCPI BATTERY REPLACEMENT DATE SHOULD BE RECORDED ON ONE OF THE ADHESIVE LABELS SUPPLIED AND AFFIXED TO THE ELT IN A READILY VISIBLE LOCATION.

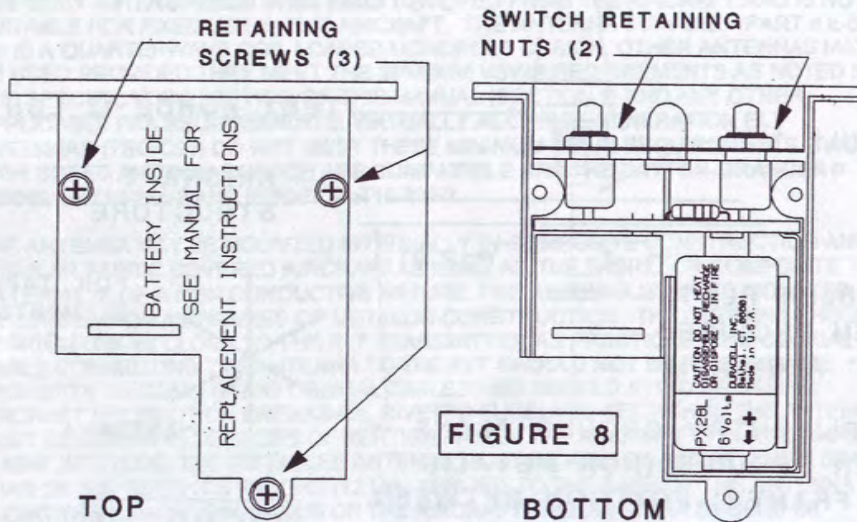

PAGE 7

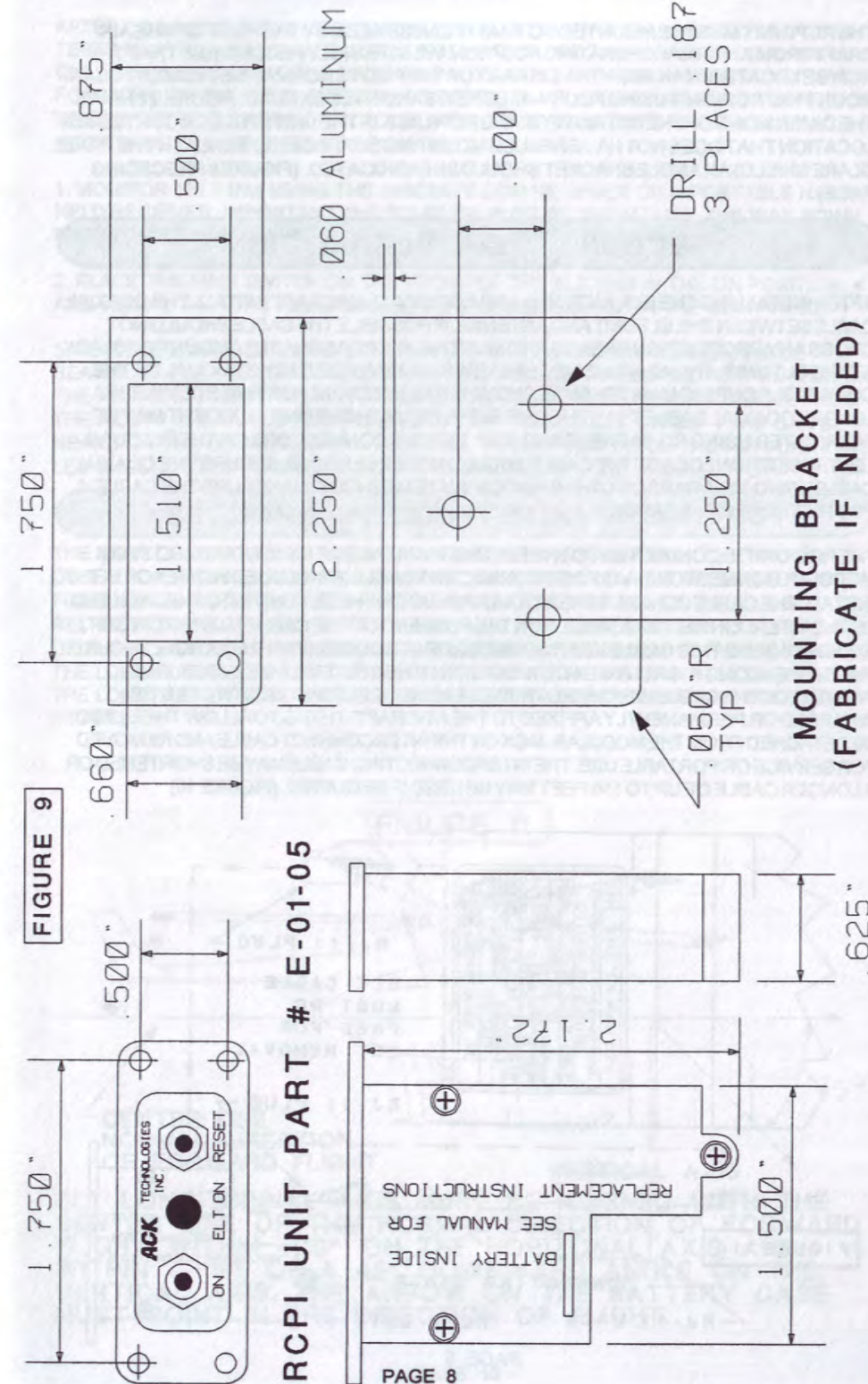

PAGE 8

THE RCPI UNIT MUST BE MOUNTED SO THAT IT CAN BE SEEN BY THE PILOT OF THE AIRCRAFT FROM A NORMAL OPERATING POSITION. WE STRONGLY RECOMMEND THAT THE RCPI BE LOCATED IN AN AREA THAT IS PART OF THE PILOTS NORMAL INSTRUMENT SCAN. MOUNT THE RCPI UNIT USING FOUR 4-40 SCREWS AND NYLOCK NUTS. FIGURE 9 SHOWS THE DIMENSIONS OF THE CUT OUT FOR THE RCPI UNIT. IF THE UNIT IS TO BE MOUNTED IN A LOCATION THAT DOES NOT HAVE A FLUSH MOUNTING SURFACE (i.e. BENEATH THE PANEL GLARE SHIELD) AN ANGLE BRACKET SHOULD BE FABRICATED. (FIGURE 9 PRECEDING PAGE)

SECTION 5 FINAL INSTALLATION

AFTER INSTALLING THE ELT, ANTENNA AND RCPI IN THE AIRCRAFT INSTALL THE COAXIAL CABLE BETWEEN THE ELT UNIT AND ANTENNA. IF POSSIBLE THE CABLE SHOULD NOT CROSS ANY PRODUCTION BREAKS AND MUST HAVE A REASONABLE AMOUNT OF SLACK AT THE ELT UNIT. THIS SLACK IS NECESSARY TO ALLOW FOR EASY REMOVAL OF THE COAX CABLE DURING MAINTENANCE AND WHEN NEEDED AS A PORTABLE DEVICE. IF A LONGER COAXIAL CABLE THAN THE ONE SUPPLIED WITH THE UNIT (4 FOOT) IT MAY BE FABRICATED USING RG-58 CABLE AND AMP 227079-5 CONNECTORS OR THEIR EQUIVALENT. INSERTION LOSS OF THE CABLE SHOULD NOT EXCEED 2 dB. SECURE THE COAXIAL CABLE USING TIE WRAPS OR OTHER APPROPRIATE METHODS. MAKE SURE THE CABLE IS PROTECTED FROM ABRASION.

THE RCPI UNIT IS CONNECTED TO THE ELT UNIT VIA MEANS OF RJ-11 STANDARD TYPE MODULAR CONNECTORS. A 16 FOOT CONNECTING CABLE IS INCLUDED WITH EACH ELT. TO INSTALL THE CABLE CONNECT THE MODULAR PLUG ON THE ELT UNIT INTO THE JACK END OF THE INTERCONNECTING CABLE. RUN THE PLUG END OF THE CABLE TO THE RCPI UNIT. AVOID RUNNING THIS CABLE NEAR SOURCES OF STRONG EMI/RFI RADIATION. SECURE THE CABLE ALONG IT'S RUN WITH TIE WRAPS OR OTHER SUITABLE METHODS. THE PORTION OF THE CABLE WHICH PROTRUDES FROM THE ELT UNIT MUST NOT BE TIE WRAPPED OR PERMANENTLY AFFIXED TO THE AIRCRAFT. THIS IS TO ALLOW THE ELT TO BE DETACHED FROM THE MODULAR JACK ON THE INTERCONNECT CABLE AND REMOVED FOR SERVICE OR PORTABLE USE. THE INTERCONNECTING CABLE MAY BE SHORTENED OR A LONGER CABLE OF UP TO 150 FEET MAY BE USED IF REQUIRED. (FIGURE 10)

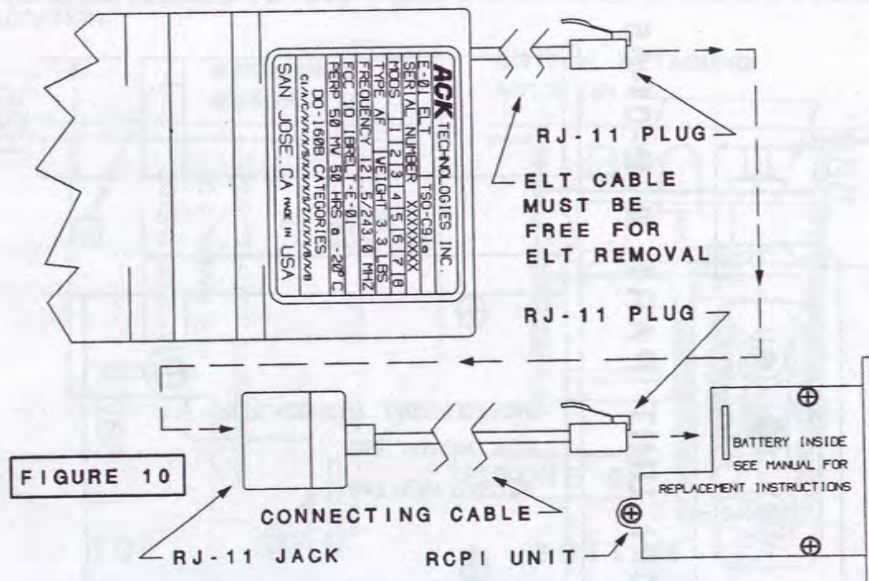

AFTER COMPLETING THE MECHANICAL INSTALLATION THE FOLLOWING FUNCTION TESTS MUST BE PERFORMED. REGULATIONS REQUIRE THAT TRANSMITTER TESTS ONLY BE DONE DURING THE FIRST 5 MINUTES OF EACH HOUR AND MUST NOT LAST FOR MORE THAN 3 AUDIO SWEEPS (1.5 SECONDS). IF YOU ARE AT A LOCATION WHERE THERE IS AN FAA CONTROL TOWER OR OTHER MONITORING FACILITY NOTIFY THE FACILITY BEFORE BEGINNING THE TESTS.

1. MONITOR 121.5 Mhz USING THE AIRCRAFT COM RECEIVER OR A PORTABLE HAND HELD RECEIVER. IMPORTANT THE SQUELCH MUST BE TURNED ALL THE WAY DOWN (OFF) TO HEAR THE SWEEP TONE ON MOST RECEIVERS.
2. PLACE THE MAIN SWITCH ON THE FRONT OF THE ELT UNIT IN THE ON POSITION AND VERIFY THAT THE AUDIO SWEEP TONE CAN BE HEARD ON THE COM RADIO.
3. PLACE THE MAIN SWITCH ON THE ELT UNIT IN THE ARMED POSITION. WHILE SEATED AT THE PILOTS NORMAL OPERATING POSITION PRESS THE "ON" BUTTON ON THE RCPI UNIT. VERIFY THAT THE RED LED FLASHES AND IS READILY VISIBLE FROM THE PILOTS OPERATING POSITION. VERIFY THAT THE AUDIO SWEEP TONE CAN BE HEARD ON THE COM RECEIVER. PUSH THE "RESET" BUTTON ON THE RCPI UNIT. THE LED SHOULD STOP FLASHING AND THE AUDIO SWEEP TONE SHOULD STOP.

SECTION 6 HELICOPTER INSTALLATIONS

THE MODEL E-01 ELT IS SUITABLE FOR HELICOPTER INSTALLATION. THE PROCEDURES FOR INSTALLATION, MAINTENANCE, AND OPERATION ARE THE SAME AS FOR FIXED WING AIRCRAFT EXCEPT FOR THE ORIENTATION OF THE OF THE ELT IN RELATION TO HELICOPTER LONGITUDINAL AXIS. THE ARROW ON THE BATTERY CASE OF THE ELT SHOULD BE POINTED IN THE NORMAL DIRECTION OF FORWARD FLIGHT. THE LONGITUDINAL AXIS OF THE ELT SHOULD BE ALIGNED WITHIN ± 10 DEGREES OF THE LONGITUDINAL AXIS HORIZONTALLY AND AT A 45 DEGREE DOWNWARD ANGLE. (FIGURE 11)

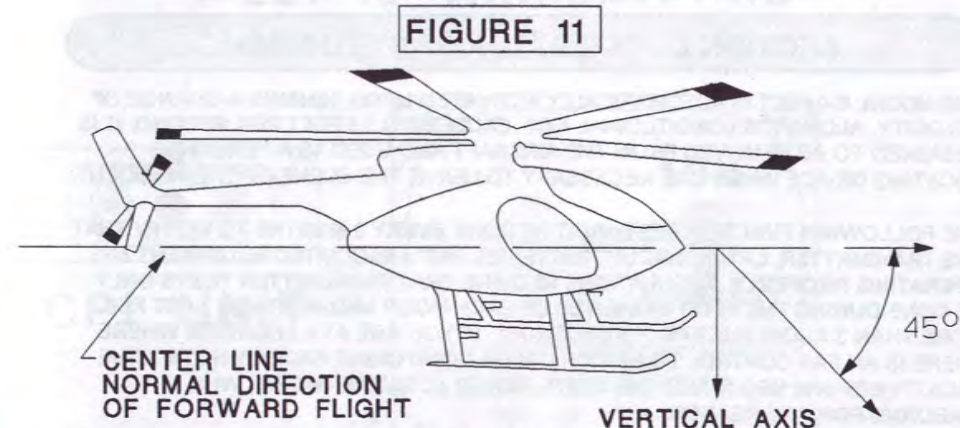

ELT LONGITUDINAL AXIS MUST BE ALIGNED WITH THE CENTER LINE OF THE NORMAL DIRECTION OF FORWARD FLIGHT WITHIN $\pm 10^\circ$ ON THE HORIZONTAL AXIS AND WITHIN $\pm 10^\circ$ OF A 45 DOWNWARD ANGLE ON THE VERTICAL AXIS. THE ARROW ON THE BATTERY CASE MUST POINT IN THE DIRECTION OF FLIGHT.

SECTION 7 PERIODIC MAINTENANCE

THE FOLLOWING INSPECTIONS MUST BE PERFORMED A MINIMUM OF ONE TIME EACH 12 MONTHS.

1. INSPECT THE ELT AND MOUNTING TRAY TO INSURE ALL FASTENERS AND MECHANICAL ASSEMBLIES ARE SECURE.
2. INSPECT THE COAXIAL CABLE CONNECTING THE ELT TO THE ANTENNA FOR CUTS OR ABRASIONS ON IT'S OUTER JACKET. DISCONNECT THE BNC CONNECTORS ON EACH END. EXAMINE BOTH THE BNC CONNECTORS AND THE MATING PLUG ON THE ANTENNA AND ELT UNIT FOR ANY SIGNS OF CORROSION.
3. INSPECT THE MODULAR CABLE CONNECTING THE ELT TO THE RCPI UNIT TO FOR SIGNS OF WEAR OR ABRASION ON IT'S OUTER JACKET. REMOVE THE MODULAR PLUG CONNECTING THE ELT TO THE CONNECTING CABLE AND INSPECT THE JACK AND PLUG ASSEMBLY FOR CORROSION.
4. CHECK THE EXPIRATION DATE OF THE ELT AND RCPI BATTERIES, REPLACE IF NECESSARY (SEE SECTION 1)
5. REMOVE THE BATTERY CASE (SEE SECTION 1) AND INSPECT THE BATTERY COMPARTMENT FOR SIGNS OF CORROSION OR BATTERY LEAKAGE. IF ANY BATTERY LEAKAGE IS PRESENT ALL BATTERIES MUST BE REPLACED. ALTHOUGH NOT REQUIRED WE STRONGLY RECOMMEND THAT THE BATTERIES BE REPLACED EVERY TWO YEARS. AFTER TWO YEARS OF STORAGE AT NORMAL TEMPERATURES THE CELLS STILL HAVE OVER 95% OF THEIR ORIGINAL CAPACITY LEFT AND MAY BE USED TO POWER OTHER NON CRITICAL ELECTRICAL DEVICES.
6. AFTER COMPLETING THE ABOVE INSPECTIONS A FUNCTION TEST AS DESCRIBED IN SECTION 5 MUST BE PREFORMED TO VERIFY PROPER OPERATION.
7. THE G-SWITCH AND AM RADIO CHECK AS DESCRIBED IN FAA ACTION NOTICE 8150.3 SUPPLEMENTAL INSPECTION PROCEDURE ITEMS 4 AND 6 MUST ALSO BE PREFORMED AT THIS TIME (SEE APPENDIX A PAGE 15).

SECTION 8 OPERATING INSTRUCTIONS

THE MODEL E-01 ELT IS AUTOMATICALLY ACTIVATED UPON SENSING A CHANGE OF VELOCITY, ALONG IT'S LONGITUDINAL AXIS, EXCEEDING 3.5 FEET PER SECOND. IT IS DESIGNED TO BE REMOVED FROM THE AIRCRAFT AND USED AS A PERSONAL LOCATING DEVICE WHEN IT IS NECESSARY TO LEAVE THE SCENE OF THE ACCIDENT.

THE FOLLOWING FUNCTION TEST MUST BE DONE EVERY 3 MONTHS TO VERIFY THAT THE TRANSMITTER, LATCH CIRCUIT, BATTERIES AND ASSOCIATED EQUIPMENT ARE OPERATING PROPERLY. REGULATIONS REQUIRE THAT TRANSMITTER TESTS ONLY BE DONE DURING THE FIRST 5 MINUTES OF EACH HOUR AND MUST NOT LAST FOR MORE THAN 3 AUDIO SWEEPS (1.5 SECONDS). IF YOU ARE AT A LOCATION WHERE THERE IS AN FAA CONTROL TOWER OR OTHER MONITORING FACILITY NOTIFY THE FACILITY BEFORE BEGINNING THE TESTS. NEVER ACTIVATE THE ELT WHILE AIRBORNE FOR ANY REASON.

1. MONITOR 121.5 Mhz USING THE AIRCRAFT COM RECEIVER OR PORTABLE HAND HELD RECEIVER. TURN THE SQUELCH ALL THE WAY DOWN OR OFF.
2. PRESS THE "ON" BUTTON ON THE RCPI UNIT (SEE FIGURE 12) VERIFY THAT THE RED LED FLASHES. VERIFY THAT THE AUDIO SWEEP TONE CAN BE HEARD ON THE COM RECEIVER. PUSH THE "RESET" BUTTON ON THE RCPI UNIT. THE LED SHOULD STOP FLASHING AND THE AUDIO SWEEP TONE SHOULD STOP.

THE RED LED ON THE RCPI WILL FLASH ON AND OFF INDICATING THE ELT IS TRANSMITTING SHOULD THE ELT BE ACCIDENTLY ACTIVATED BY TURBULENCE, HARD LANDING, ETC. SHOULD THIS OCCUR UNDER ANY CONDITIONS OTHER THAN AN ACCIDENT REQUIRING IMMEDIATE ASSISTANCE, THE ELT SHOULD BE RESET BY PRESSING THE "RESET" BUTTON ON THE RCPI UNIT. (SEE FIGURE 12) IF THE AIRCRAFT IS ON THE GROUND AND THE "RESET" BUTTON DOES NOT CAUSE THE LED TO STOP FLASHING THE MAIN SWITCH ON THE ELT UNIT SHOULD BE SET TO THE OFF POSITION (SEE FIGURE 12). IF AIRBORNE AND THE "RESET" BUTTON DOES NOT CAUSE THE LED TO STOP FLASHING. THE MAIN SWITCH ON THE ELT SHOULD BE SET TO THE OFF POSITION IF THE ELT IS ACCESSIBLE. IF THE ELT IS NOT ACCESSIBLE IN FLIGHT YOU SHOULD LAND AT THE NEAREST SUITABLE AIRPORT AND SET THE MAIN SWITCH TO THE OFF POSITION. IN EITHER CASE THE UNIT SHOULD BE INSPECTED BY A QUALIFIED FACILITY AS SOON AS POSSIBLE. THE AIRCRAFT MAY BE OPERATED WITH THE ELT REMOVED FOR INSPECTION OR REPAIR SUBJECT TO THE CONDITIONS OF FAR 91.207.

IN THE EVENT OF AN ACCIDENT THE EXTERNAL AIRCRAFT ANTENNA SHOULD BE INSPECTED FOR DAMAGE. IF THE ANTENNA IS BROKEN OFF OF THE AIRCRAFT THE ELT UNIT SHOULD BE REMOVED AND THE PORTABLE ANTENNA USED IN IT'S FULLY EXTENDED POSITION. IF THE ELT UNIT IS TO REMAIN AT THE AIRCRAFT SITE IT SHOULD BE PLACED ON A LARGE METALLIC PORTION OF THE AIRFRAME WITH IT'S ANTENNA POINTING SKYWARD. THE LED INDICATOR SHOULD BE FLASHING ON THE RCPI UNIT AFTER THE ACCIDENT. IF THE ELT IS ACCESSIBLE AFTER THE ACCIDENT PLACE THE MAIN SWITCH IN THE ON POSITION AND MONITOR IT ON 121.5 Mhz FOR PROPER OPERATION IF POSSIBLE.

IF THE ELT IS TO BE TAKEN ALONG AS A PORTABLE UNIT WHEN LEAVING THE SCENE OF THE ACCIDENT PLACE THE MAIN SWITCH IN THE ON POSITION AND KEEP THE ANTENNA VERTICALLY ORIENTED AS MUCH AS POSSIBLE. THE MODULAR CABLE ASSEMBLY PLUGS BACK INTO THE FRONT OF THE ELT UNIT TO FORM A HANDLE OR FOR USE AS A TETHER. WHEN USED AS A PORTABLE UNIT IN COLD WEATHER THE ELT UNIT SHOULD BE KEPT AS WARM AS POSSIBLE BY PLACING IT INSIDE YOUR CLOTHING WITH THE ANTENNA PROTRUDING.

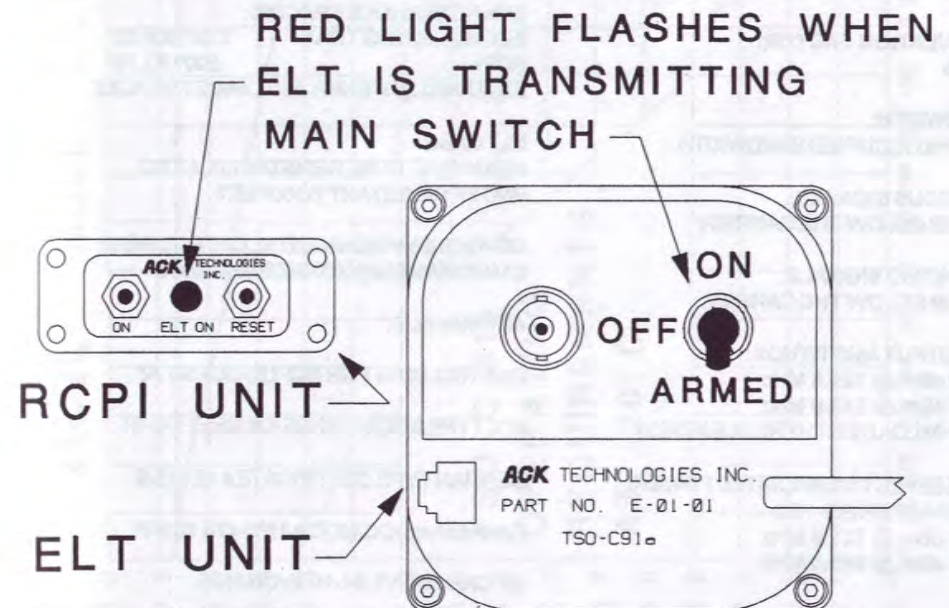

FIGURE 12

SECTION 9 SPECIFICATIONS

TRANSMISSION FREQUENCIES:
121.5 MHz AND 243.0 MHz

FREQUENCY STABILITY:
± 0.003% @ -20 TO +55 DEGREES C

MODULATION TRANSMISSION TYPES:

TYPE 3K20A3N COHERENT BEACON
THE CARRIER IS MODULATED WITH A
DIGITALLY GENERATED SWEEPED AUDIO
CARRIER

SWEEP RATE:
2.5 Hz ± 10%

AUDIO CHARACTERISTICS:
DOWNWARD SWEEPING
FROM 1400 TO 600 Hz

MODULATION DUTY CYCLE:
50% SQUARE WAVE AMPTITUDE
MODULATION

TRANSMITTER DUTY CYCLE:
100%

MODULATION FACTOR:
> 90%

BANDWIDTH:
< 25 KHz OCCUPIED BANDWIDTH

SPURIOUS SIGNALS:
> -80 dB BELOW THE CARRIER

HARMONIC SIGNALS:
> -40 dB BELOW THE CARRIER

RF OUTPUT AMPTITUDE:
+21.0 dBm @ 121.5 MHz
+16.9 dBm @ 243.0 MHz
(50 OHM LOAD BOTH FREQUENCIES)

PEAK EFFECTIVE RADIATED POWER:
(PERP AS PER DO-183)
+17.7 dBm @ 121.5 MHz
+19.3 dBm @ 243.0 MHz

ANTENNA CHARACTERISTICS:
(ON A 1/2 WAVE GROUND PLANE)
SVWR @ 121.5 MHz < 1.5:1
SVWR @ 243.0 MHz < 1.4:1

BATTERY REQUIREMENTS:

TRANSMITTER
EIGHT DURACELL® MN1300 "D" CELLS

RCPI UNIT
ONE DURACELL® PX28L LITHIUM CELL

AVERAGE CURRENT DRAIN:
79 MILLIAMPS

SIZE:
ELT 7.75" X 2.75" X 2.75"
RCPI 2.75" X 2.00" X 0.75"
EXTERNAL ANTENNA 18.5" LONG

WEIGHTS:
ELT AND MOUNTING TRAY 3 Lbs 6.0 Oz
RCPI UNIT 1.0 Oz
EXTERNAL ANTENNA 1.5 Oz

MOUNTING HOLE SPACING:
ELT MOUNTING TRAY 2.00" X 5.50"
RCPI .500" X 1.75"
EXTERNAL ANTENNA .500" DIAMETER HOLE

ELT CASE:
HIGH IMPACT FIRE RESISTANT PLASTIC
WATER RESISTANT TO 60 FEET

DO-160B ENVIRONMENTAL CATEGORIES:
C1/A/C/X/X/S/X/X/X/S/Z/X/X/B/X/B

APPROVALS:

FAA TSO-C91a FOR DO-183 CLASS AF

FCC TYPE ACCEPTANCE ID# IBRELT-E-01

GERMAN TYPE CERTIFICATE # 10.915/9

CANADIAN DOC/MDC # 1863 474 101FP

UK CAA BCAR B4-10 #VCO1125

ALL WIRE SUPPLIED WITH THIS ELT MEETS OR EXCEEDS THE REQUIREMENTS OF FAR 23.1359

MANUAL:
PART NUMBER E-01-M REV. 05/07/2002

OUTPUT POWER IN MILLIWATTS

ACK MODEL E-01 OPERATING LIFE

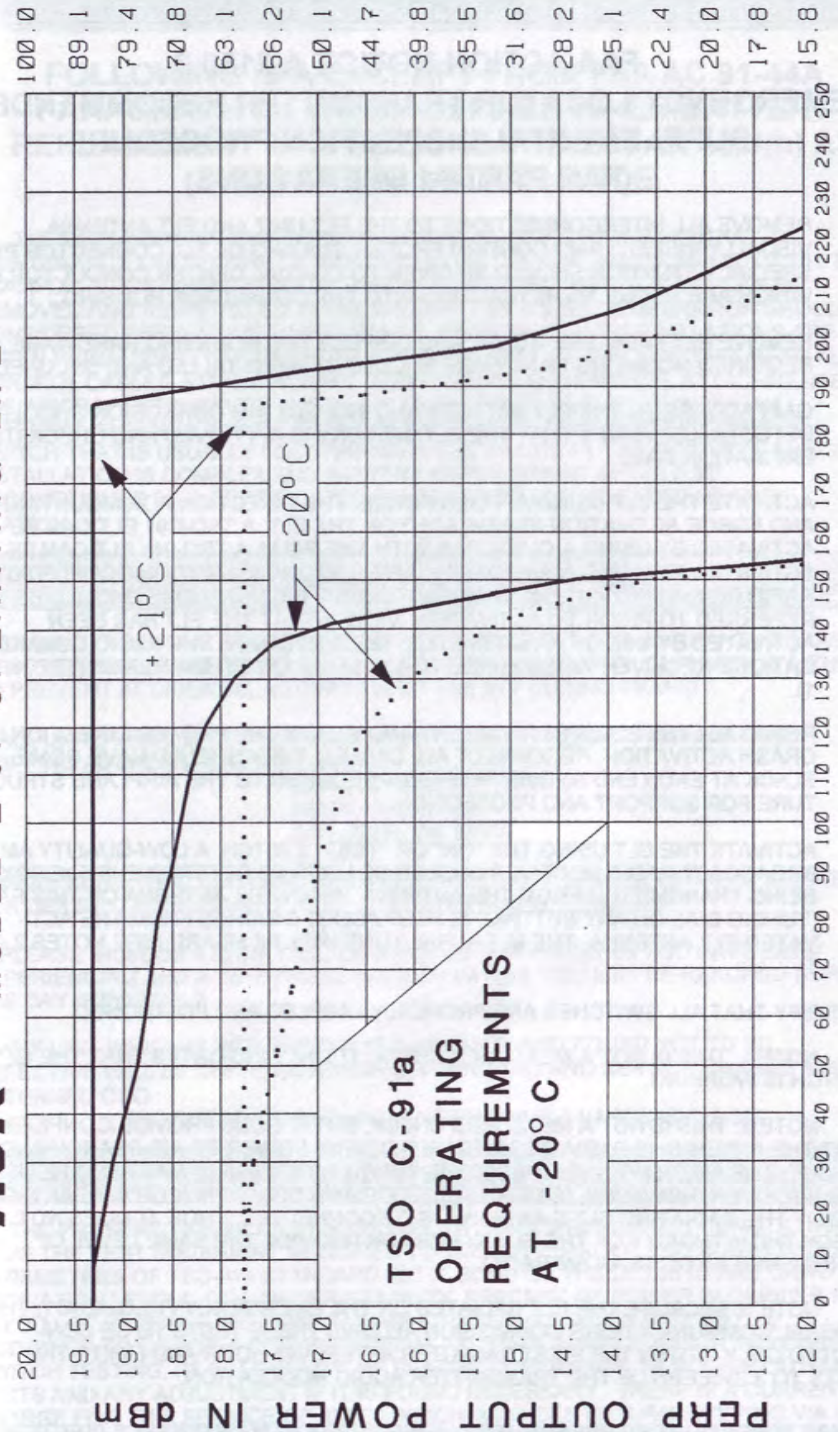

PERP OUTPUT POWER IN dBm

121.5 MHz..... TIME IN HOURS 243.0 MHz

APPENDIX A

FAA ACTION NOTICE A 8150.3 EMERGENCY LOCATOR TRANSMITTER RECOMMENDED SUPPLEMENTAL INSPECTION PROCEDURE (FAR PART 91 OPERATIONS)

1. REMOVE ALL INTERCONNECTIONS TO THE ELT UNIT AND ELT ANTENNA. VISUALLY INSPECT AND CONFIRM PROPER SEATING OF ALL CONNECTOR PINS. SPECIAL ATTENTION SHOULD BE GIVEN TO COAXIAL CENTER CONDUCTOR PINS WHICH ARE PRONE TO RETRACTING INTO THE CONNECTOR HOUSING.
2. REMOVE ELT FROM THE MOUNT AND INSPECT THE MOUNTING HARDWARE. ALL REQUIRED MOUNTING HARDWARE SHOULD BE REINSTALLED AND SECURED.
3. GAIN ACCESS TO THE ELT BATTERY AND INSPECT. NO CORROSION SHOULD BE DETECTABLE. VERIFY THAT THE ELT BATTERY IS APPROVED AND CHECK ITS EXPIRATION DATE.
- * 4. ACTIVATE THE ELT USING APPLIED FORCE. THE DIRECTION FOR MOUNTING AND FORCE ACTIVATION IS INDICATED ON THE ELT. A TSO-C91 ELT CAN BE ACTIVATED BY USING A QUICK RAP WITH THE PALM. A TSO-91a ELT CAN BE ACTIVATED BY USING A RAPID FORWARD (THROWING) MOTION COUPLED BY A RAPID REVERSING ACTION. MANUFACTURER'S INSTRUCTIONS SHOULD BE REFERRED TO PRIOR TO ACTIVATION. VERIFY THAT THE ELT HAS BEEN ACTIVATED BY USE OF A WATTMETER, THE AIRPLANE'S VHF RADIO COMMUNICATIONS RECEIVER WHEN TUNED TO 121.5 Mhz, OR OTHER MEANS (SEE NOTE 1).
5. REINSTALL THE ELT INTO ITS MOUNT AND VERIFY THE PROPER DIRECTION FOR CRASH ACTIVATION. RECONNECT ALL CABLES. THEY SHOULD HAVE SOME SLACK AT EACH END AND BE PROPERLY SECURED TO THE AIRPLANE STRUCTURE FOR SUPPORT AND PROTECTION.
- * 6. ACTIVATE THE ELT USING THE "ON" OR "TEST" SWITCH. A LOW-QUALITY AM BROADCAST RADIO RECEIVER SHOULD BE USED TO DETERMINE IF ENERGY IS BEING TRANSMITTED FROM THE ANTENNA. WHEN THE ANTENNA OF THIS RADIO (TUNING DIAL ON ANY SETTING) IS HELD ABOUT 6-INCHES FROM THE ACTIVATED ELT ANTENNA, THE ELT AURAL TONE WILL BE HEARD (SEE NOTES 2 AND 3).
7. VERIFY THAT ALL SWITCHES ARE PROPERLY LABELED AND POSITIONED.

NOTE 1: THIS IS NOT A MEASURED CHECK: IT ONLY INDICATES THAT THE G-SWITCH IS WORKING.

NOTE 2: THIS IS NOT A MEASURED CHECK, BUT IT DOES PROVIDE CONFIDENCE THAT THE ANTENNA IS RADIATING WITH SUFFICIENT POWER TO AID SEARCH AND RESCUE. THE AIRCRAFT'S VHF RECEIVER, TUNED TO 121.5 MHz, MAY ALSO BE USED. THIS RECEIVER, HOWEVER, IS MORE SENSITIVE AND COULD PICK UP A WEAK SIGNAL EVEN IF THE RADIATING ELT'S ANTENNA IS DISCONNECTED. THUS, IT DOES NOT CHECK THE INTEGRITY OF THE ELT SYSTEM OR PROVIDE THE SAME LEVEL OF CONFIDENCE AS DOES AN AM RADIO.

NOTE 3: BECAUSE THE ELT RADIATES ON THE EMERGENCY FREQUENCY, THE FEDERAL COMMUNICATIONS COMMISSION ALLOWS THESE TESTS TO BE CONDUCTED ONLY WITHIN THE FIRST 5 MINUTES AFTER ANY HOUR AND LIMITS THE TESTS TO 3 SWEEPS OF THE TRANSMITTER AUDIO MODULATION.

* THESE TESTS MUST BE PREFORMED DURING PERIODIC MAINTENANCE (SECTION 7)

APPENDIX B

FOLLOWING IS A EXCERPT FROM FAA AC 91-44A PARAGRAPH 8.a WHICH DEFINES WHEN BATTERY REPLACEMENT MAY BE DONE UNDER FAR 43.3(h) AS PREVENTIVE MAINTENANCE.

"...THE REPLACEMENT CAN BE DONE BY THE PILOT IF THE PREVENTIVE MAINTENANCE LIMITATIONS OF PART 43.3(h) OF THE FAR, ARE COMPLIED WITH. FOR EXAMPLE, A PORTABLE TYPE ELT THAT IS READILY ACCESSIBLE AND CAN BE REMOVED AND REINSTALLED IN THE AIRCRAFT BY A SIMPLE OPERATION SHOULD BE CONSIDERED PREVENTIVE MAINTENANCE. FIXED TYPE ELT INSTALLATIONS ARE OFTEN PERMANENTLY MOUNTED IN A REMOTE AREA OF THE AIRCRAFT NEAR FLIGHT CONTROL CABLES, VITAL AIRCRAFT COMPONENTS AND CRITICAL ATTACHMENTS TO THE AIRCRAFT STRUCTURE. INSTALLATIONS OF THIS NATURE REQUIRE AN EXTERNAL ANTENNA AND OFTEN A REMOTE ON/OFF TRANSMITTER CONTROL SWITCH THAT IS USUALLY LOCATED NEAR THE PILOT'S FLIGHT POSITION. THIS TYPE INSTALLATION IS COMPLEX AND BATTERY REPLACEMENT SHOULD BE ACCOMPLISHED BY A CERTIFICATED MECHANIC OR CERTIFICATED REPAIR STATION...."

WARRANTY PROCEDURE

1. SHOULD IT BECOME NECESSARY TO RETURN THE ELT FOR WARRANTY REPAIR REMOVE THE ELT BATTERIES BEFORE SHIPPING THE UNIT TO OUR FACILITY. THIS IS TO PREVENT ACCIDENTAL ACTIVATION OF THE ELT DURING TRANSIT.
2. ALL UNITS MUST BE RETURNED TO OUR FACILITY FREIGHT PREPAID. OUR SHIPPING ADDRESS IS AS FOLLOWS:
ACK TECHNOLOGIES, INC.
440 W. JULIAN ST.
SAN JOSE, CA 95110
3. MAKE SURE THAT YOU HAVE INCLUDED A RETURN ADDRESS WHICH IS SUITABLE FOR UPS RETURN SHIPMENT (NO P.O. BOXES OR APO NUMBERS).
4. PLEASE INCLUDE A SHORT DESCRIPTION OF THE PROBLEM YOU HAVE BEEN EXPERIENCING AND A TELEPHONE NUMBER WHERE YOU MAY BE REACHED DURING THE DAY IF POSSIBLE.
5. ANY UNIT WHICH IS RETURNED FOR WARRANTY AND FOUND NOT TO BE DEFECTIVE WILL BE CHARGED A MINIMUM HANDLING AND SERVICE CHARGE AND RETURNED COD
(THE CURRENT HANDLING AND SHIPPING CHARGE IS \$15.00).

FACTORY SERVICE

AT THE PRESENT TIME MOST CERTIFICATED AVIONICS REPAIR STATIONS DO NOT HAVE THE TEST EQUIPMENT REQUIRED TO TEST SEVERAL OF THE MOST CRITICAL PARAMETERS OF TSO-91a STANDARD ELT'S. SOME OF THESE TESTS ARE G-SWITCH ACTIVATION LEVELS, RF CARRIER STABILITY, PERCENT OF POWER IN CARRIER ETC. IF YOU LOCAL REPAIR STATION IS UNABLE TO SERVICE YOUR UNIT MAY BE RETURNED TO US FOR A COMPREHENSIVE FACTORY SERVICE WHICH INCLUDES G-SWITCH TESTING, RF FREQUENCY, RF BEACON COHERENCE, RF POWER OUTPUT TESTS AND ANY ADJUSTMENT IF IT IS FOUND NECESSARY. THERE IS A CURRENT CHARGE FOR THIS SERVICE OF \$35.00 WHICH INCLUDES RETURN SHIPPING VIA UPS GROUND SERVICE. ALL UNITS RETURNED FOR FACTORY SERVICE MUST BE SENT FREIGHT PREPAID.

MAJOR REPLACEMENT PARTS LIST

TRANSMITTER ASSEMBLY COMPLETE NOT SOLD SEPARATLY

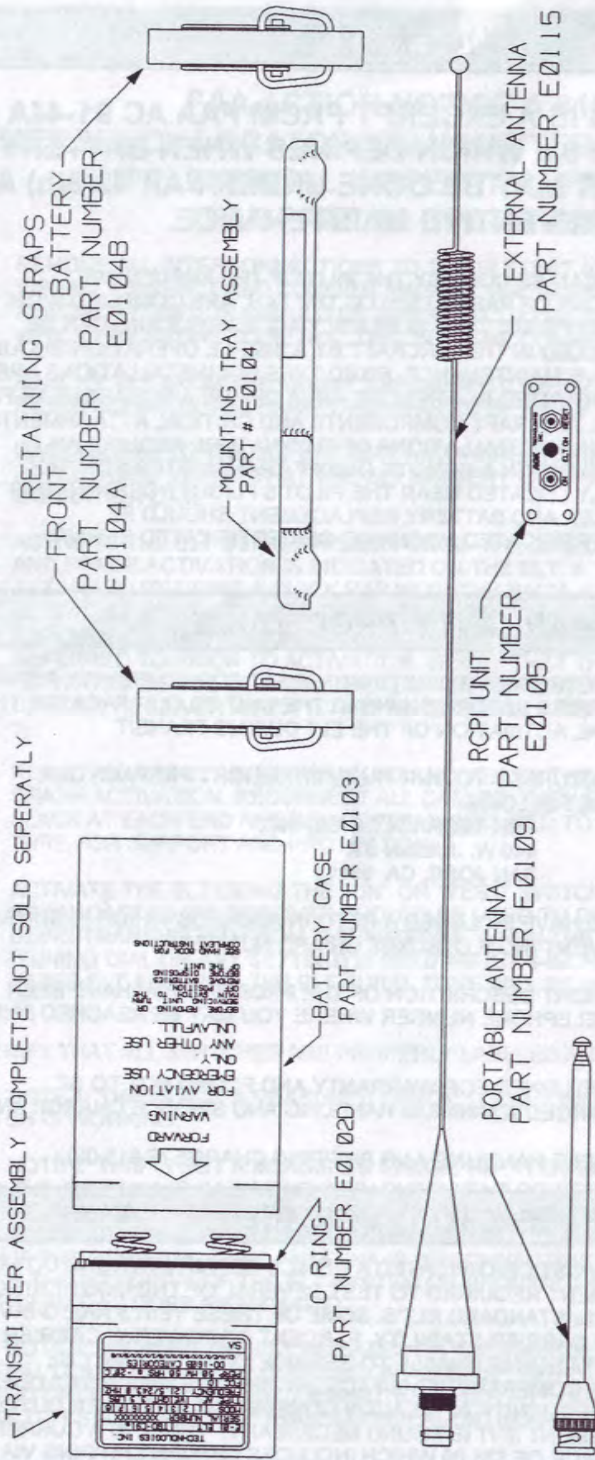

PRICE LIST REPLACEMENT PARTS

PART #	DESCRIPTION	PRICE	PART #	DESCRIPTION	PRICE
E0103	BATTERY CASE	20.00	E0104B	STRAP (BATTERY)	7.00
E0102D	O RING	2.00	E0115	EXTERNAL ANTENNA	30.00
E0104	MOUNTING TRAY	15.00	E0109	PORTABLE ANTENNA	18.00
E0104A	STRAP (FRONT)	7.00	E0105	RCPI UNIT	35.00

MINIMUM ORDER \$15.00

ALL PRICES SUBJECT TO CHANGE

SPECIAL INSTRUCTIONS CANADIAN INSTALLATION

SUPPLEMENTAL INSTALLATION AND MAINTENANCE INSTRUCTIONS

THE FOLLOWING SUPPLEMENTAL INSTALLATION AND PERIODIC MAINTENANCE REQUIREMENTS MUST BE COMPLIED WITH WHEN INSTALLING THE MODEL ACK TECHNOLOGIES MODEL E-01 ELT IN CANADIAN AIRCRAFT

INSTALLATION

1. INSTALLATION AND MAINTENANCE OF THE ELT MUST COMPLY WITH TRANSPORT CANADA ENGINEERING AND INSPECTION MANUAL PART II, CHAPTER III, SECTION 3.12.
2. A PLACARD SHALL BE FABRICATED AND INSTALLED NEAR THE RCPI WHICH STATES:

**FOR AVIATION EMERGENCY USE ONLY
UNAUTHORIZED OPERATION PROHIBITED**

PERIODIC MAINTENANCE

IN ADDITION TO THE PERIODIC MAINTENANCE REQUIREMENTS PRESCRIBED IN SECTION 7 OF OUR INSTALLATION AND OPERATION MANUAL THE FOLLOWING TESTS MUST BE PERFORMED TO COMPLY WITH ENGINEERING AND INSPECTION MANUAL PART II, CHAPTER III, SECTION 3.12.7 (e)

THESE TESTS SHOULD BE PERFORMED ONLY WITHIN AN RF SCREEN ROOM OR FACILITY PROVIDING SHIELDING OF RF EMISSIONS.

CONNECT THE RF OUTPUT OF THE ELT TO A HP MODEL 8568B SPECTRUM ANALYZER OR EQUIVALENT.

TURN THE ELT MAIN SWITCH TO THE ON POSITION AND ALLOW THE UNIT TO OPERATE FOR A MINIMUM PERIOD OF 3 MINUTES.

EQUIPMENT SETTINGS

ATTENUATION 30dB CENTER 121.5MHz RESOLUTION B/W 300 Hz
VIDEO B/W 300 Hz SWEEP 1.0 SEC

1. OBSERVE SIGNAL PLACE CURSOR IN PEAK FIND MODE FREQUENCY MUST BE 121.5 MHz +/- 5 KHz

EQUIPMENT SETTINGS

ATTENUATION 30dB START 80 MHz STOP 450 MHz
RESOLUTION B/W 3MHz VIDEO B/W 1MHz SWEEP 20 mSEC

1. MINIMUM PEAK POWER SHOULD BE 19.5 dBm AT THE 121.5 MHz FREQUENCY. MINIMUM PEAK POWER SHOULD BE 13.5 dBm AT THE 243.0 MHz FREQUENCY.

ALTERNATE COMMONLY ACCEPTED METHODS OF MEASURING POWER AND FREQUENCY MAY BE UTILIZED TO PERFORM THESE TESTS. IF MEASURING POWER WITH AN AVERAGE POWER METER BE SURE TO ADD + 3 dBm TO THE MEASUREMENTS TO OBTAIN PEAK POWER. (50% MODULATION)