

SMD SHIELDED POWER INDUCTORS SERIES SHS1208

FEATURES

- 100% ferrite shielding, zero cross talk
- Very high current handling capacity in a small size
- Available in bulk or tape and reel

ELECTRICAL SPECIFICATIONS

- Inductance range 1.0uH to 47uH*
- Test frequency 1 KHz
- Test equipment Quadtech 1750 LCR Meter
- Rated current range 2.5 Amps to 10 Amps
- Tolerance $\pm 10\%$ or $\pm 20\%$ depends on L value
- Rated current Obtained when L_0 drops 10% typical

PHYSICAL SPECIFICATIONS

- Operating temp. -40°C to $+125^{\circ}\text{C}$
- Construction Wound ferrite bobbin covered with ferrite sleeve
- Shielding Less than 2% coupling
- Terminal Flat tinned T-shape copper wire
- **NOTE: Straight terminal is available under part number with suffix S**
- Packaging Bulk 100 pieces per bag
T & R 500 pieces per reel
- Tape & reel spec. Tape 24 mm embossed carrier tape
Reel 330 mm paper or plastic reel

DIMENSIONS IN MILLIMETERS

- Square side A 12.0 ± 0.4
- Height B 8.0 ± 0.3
- Terminal length C 6.5 nominal
- Terminal width D 3.4 nominal
- Space between terminals E 5.1 nominal

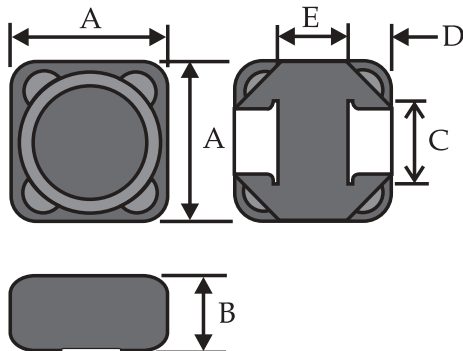

- * NOTE:
Other inductance values are available on special order.

SPECIFICATIONS

Part Number	L (μH)	Tol % \pm	DCR max (Ω)	Rated Current (DC) max (mA)
SHS1208-1R0M	1.0	20	0.009	10000
SHS1208-1R2M	1.2	20	0.010	9800
SHS1208-2R4M	2.4	20	0.014	8000
SHS1208-3R5M	3.5	20	0.015	7500
SHS1208-4R7K	4.7	10	0.017	6800
SHS1208-6R1K	6.1	10	0.020	6600
SHS1208-7R6K	7.6	10	0.022	5900
SHS1208-100K	10	10	0.024	5400
SHS1208-120K	12	10	0.028	4900
SHS1208-150K	15	10	0.032	4500
SHS1208-180K	18	10	0.043	3900
SHS1208-220K	22	10	0.046	3600
SHS1208-270K	27	10	0.049	3400
SHS1208-330K	33	10	0.064	3000
SHS1208-390K	39	10	0.070	2750
SHS1208-470K	47	10	0.090	2500

DIMENSIONS OF STRAIGHT TERMINAL

- Terminal length C 4.9 nominal
- Terminal width D 3.0 nominal
- Space between terminals E 5.1 nominal

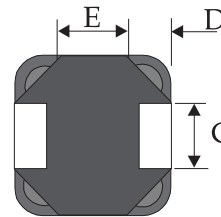

SUGGESTED LAND PATTERN

