

REV	REVISION	BY	ECN	DATE

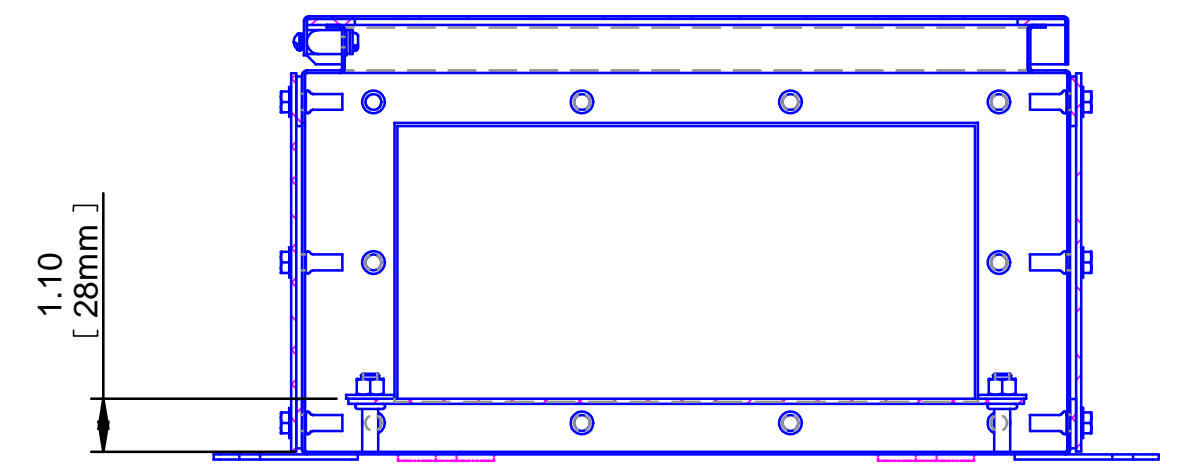
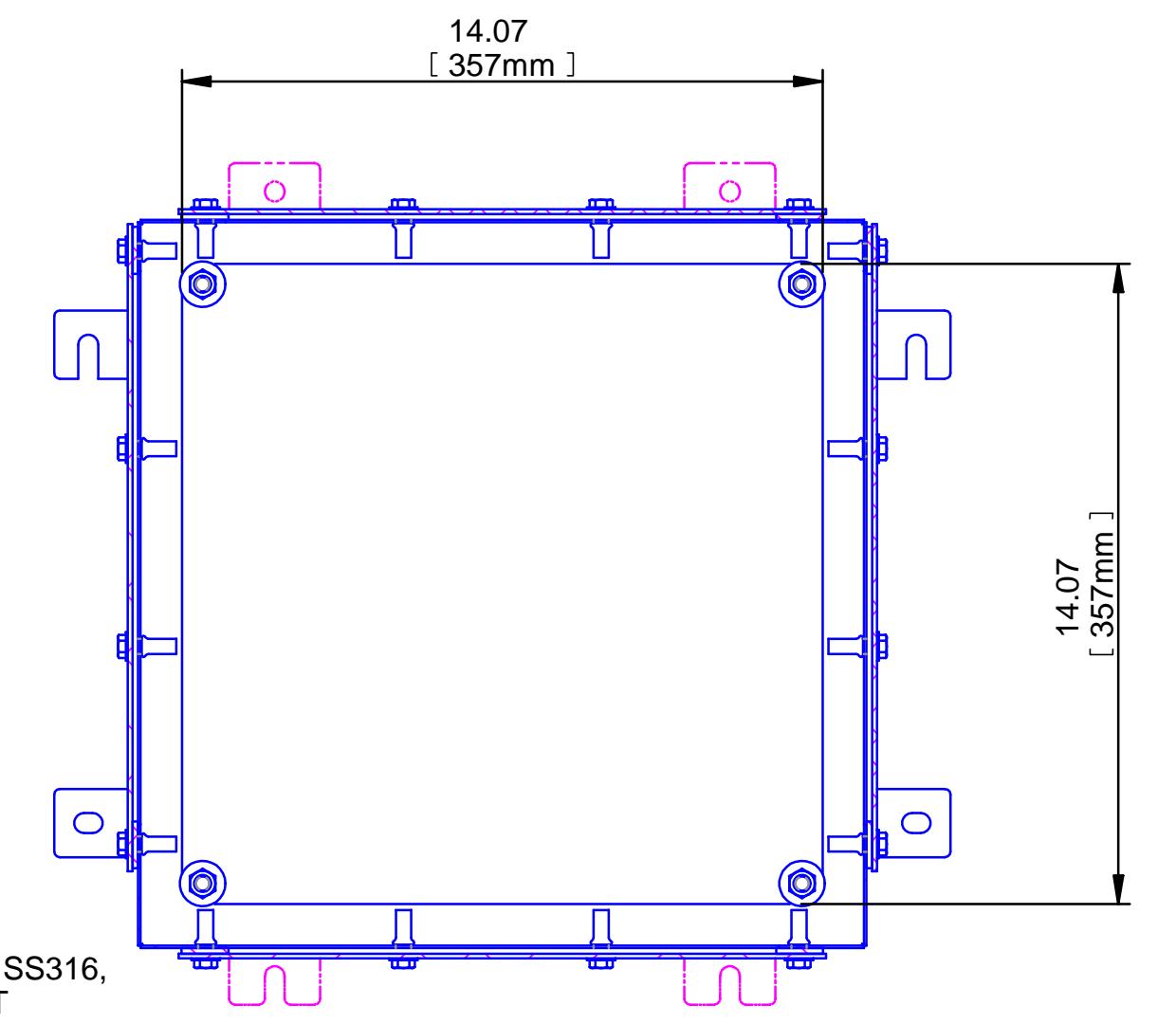
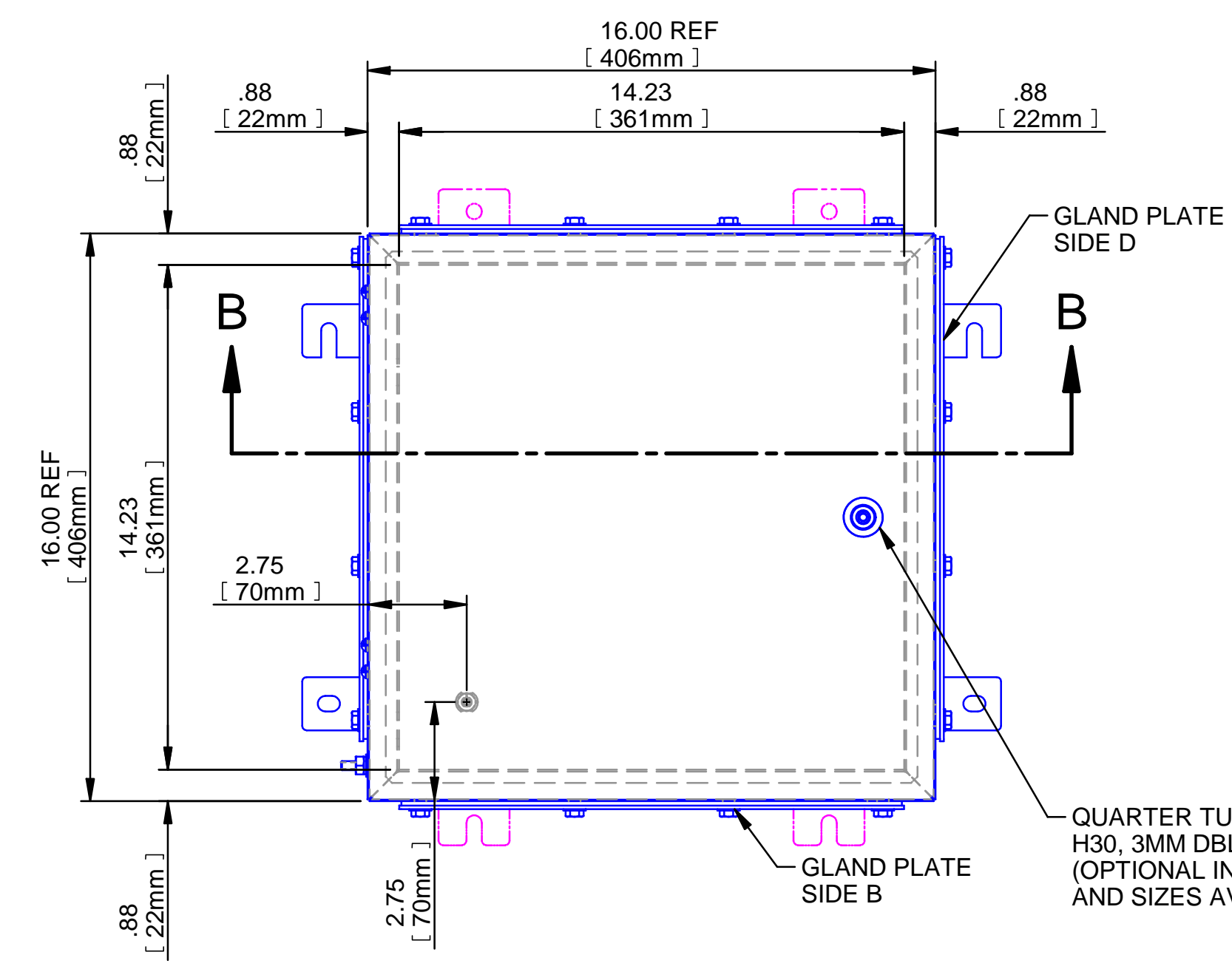
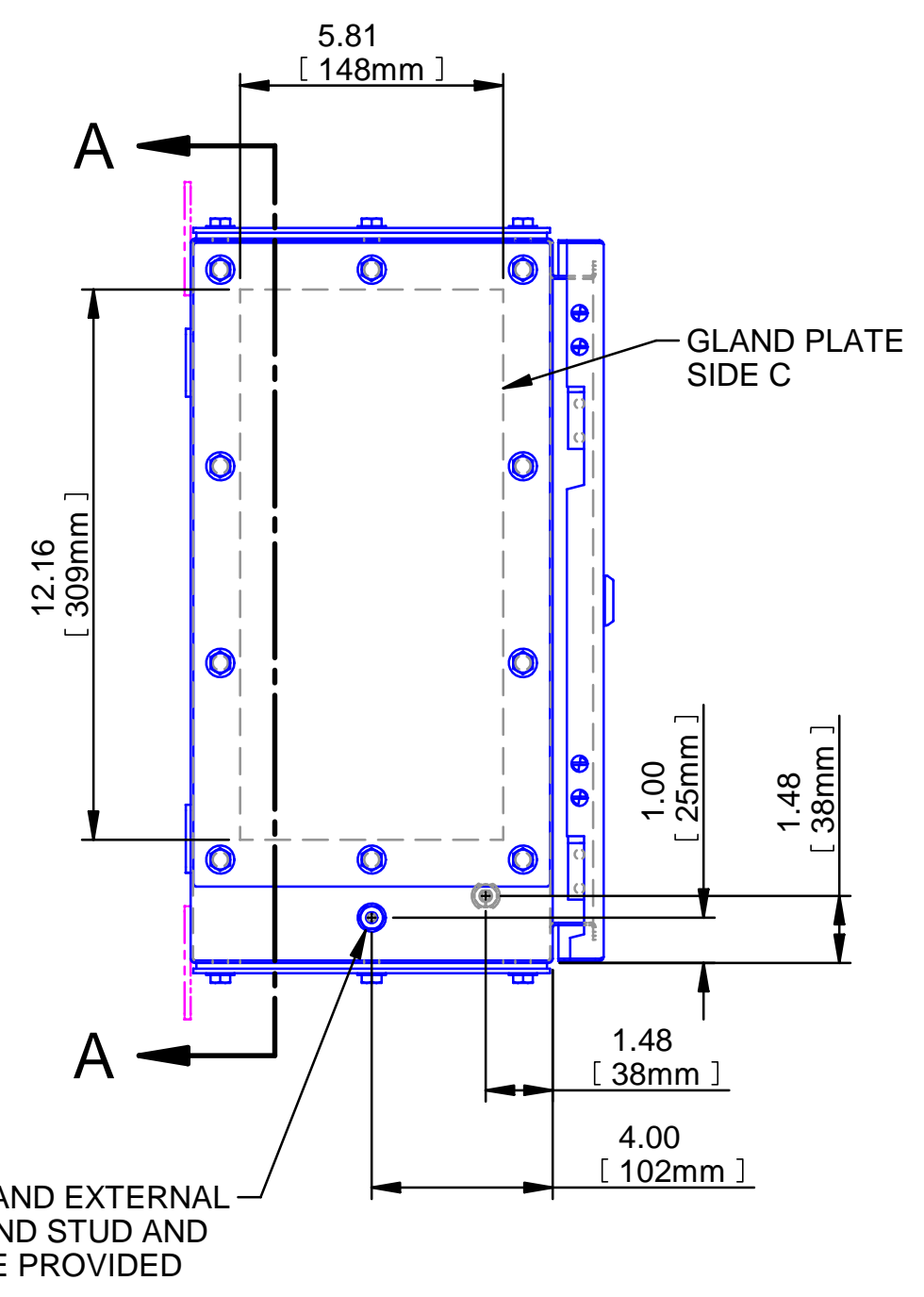
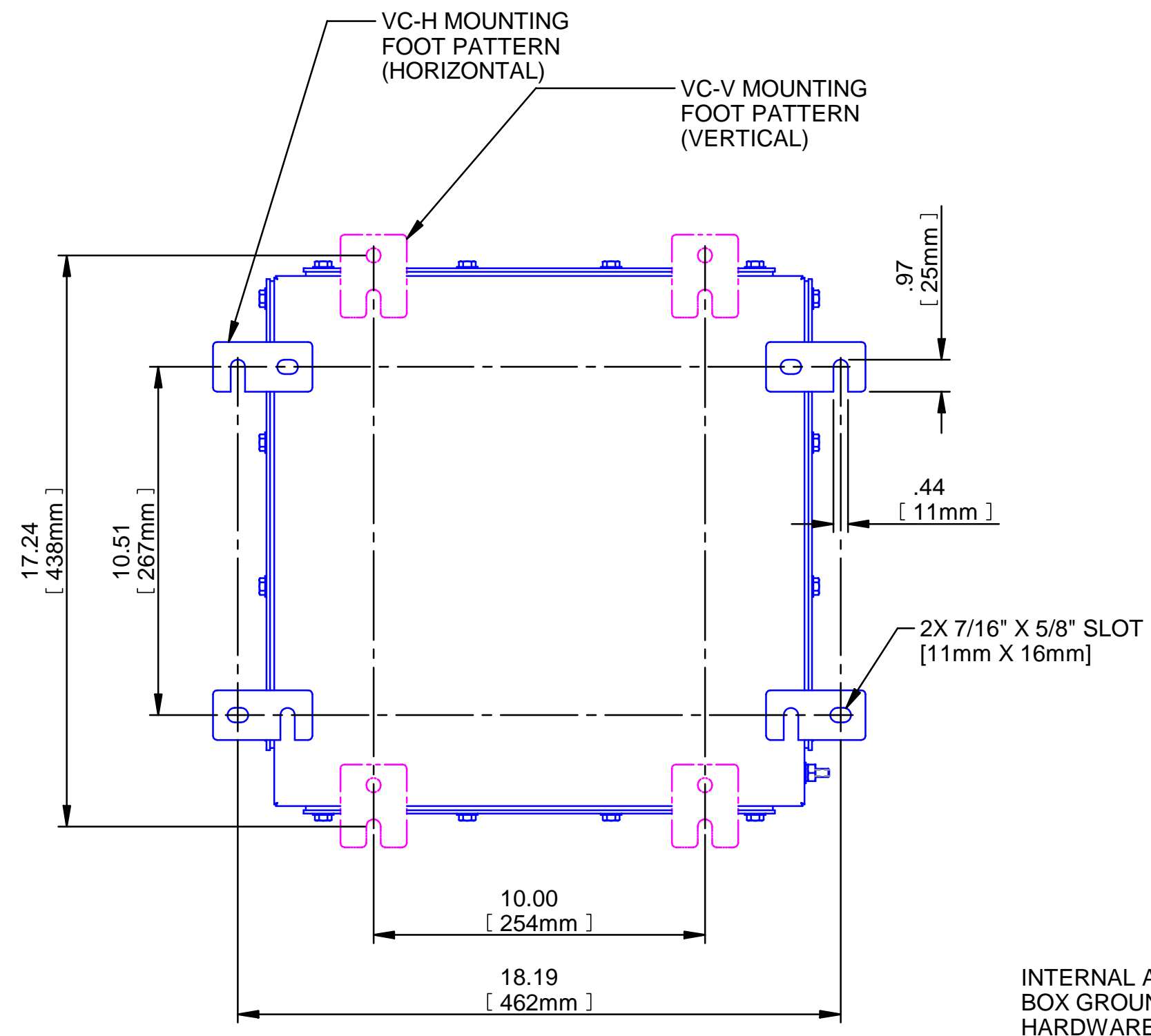
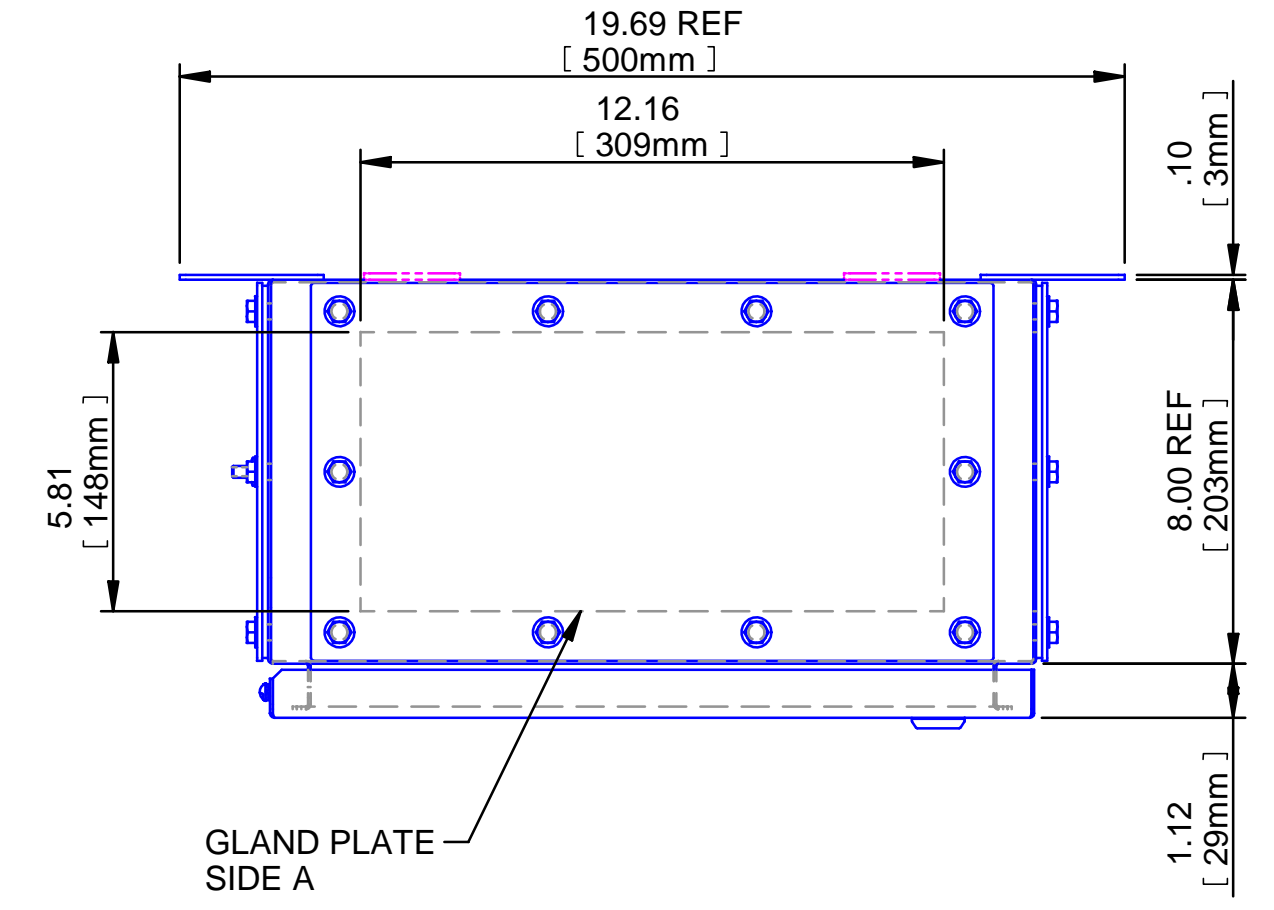
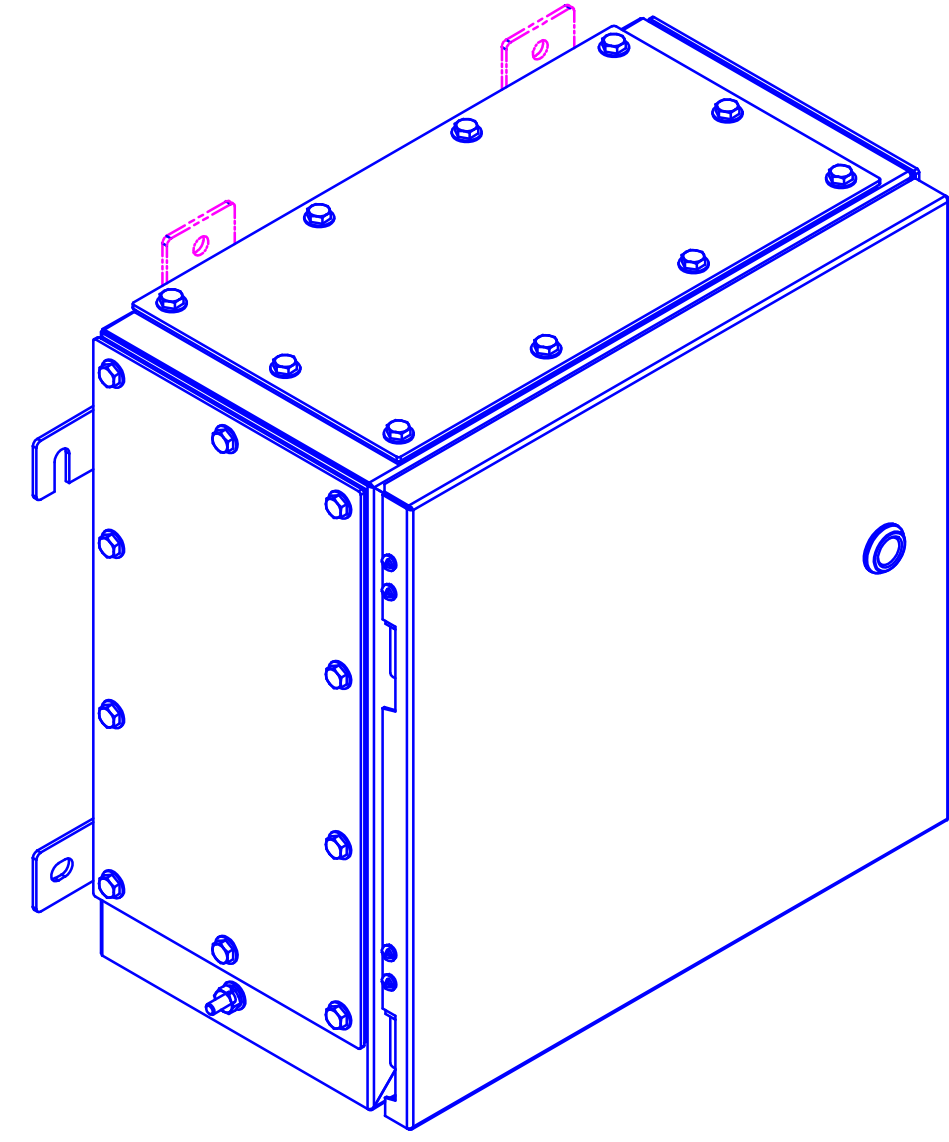

QUARTER TURN, SS316, H30, 3MM DBL BIT (OPTIONAL INSERT TYPES AND SIZES AVAILABLE)

INTERNAL AND EXTERNAL BOX GROUND STUD AND HARDWARE PROVIDED

SECTION A-A

SECTION B-B

UNCONTROLLED DRAWING
(DATA SUBJECT TO CHANGE WITHOUT NOTICE)

DO NOT REVISE THIS DWG. IN AUTOCAD 3D GENERATED IN SOLID EDGE

<p>DO NOT SCALE DRAWING UNLESS OTHERWISE SPECIFIED DIMENSIONS ARE IN INCHES CAST TOLERANCES ON DIMENSIONS NOT OTHERWISE SPECIFIED: ✓ = 1/8" STOCK Fillet or corner radii 1/8" DRAFT 1:1/2" FRACTION ± 1/16" ANGLES ± 1° MACHINE TOLERANCES ON DIMENSIONS NOT OTHERWISE SPECIFIED: ✓ = 125 MIN XXX ± .010" FILLET RADI .03" EDGE BREAK .035"-.015" R. or 45° ANGLES ± 0°30' GAGING FOR THREADED HOLES NOT OTHERWISE SPECIFIED: MFT E-212.6 NPSM E-241.0</p>		<p>ADALET A SCOTT FETZER COMPANY Enclosure Systems • Cable Accessories Cleveland, OH 44135</p>		<p>TITLE VC-161608 INCREASED SAFETY ENCLOSURE CUSTOMER OUTLINE DRAWING</p>	
<p>NOTICE TO PERSONS RECEIVING THIS DRAWING: ADALET-PLM CLAIMS PROPRIETARY RIGHTS IN THE MATERIAL DISCLOSED HEREIN. THIS DRAWING IS ISSUED IN CONFIDENCE FOR ENGINEERING INFORMATION ONLY AND MAY NOT BE REPRODUCED OR USED TO MANUFACTURE ANYTHING SHOWN HEREON, WITHOUT DIRECT WRITTEN PERMISSION FROM ADALET-PLM TO THE USER.</p>		<p>DRAWN BY DMS DATE 12/4/2008</p>		<p>ENG APPROVAL</p>	
<p>MATERIAL</p>		<p>MFG APPROVAL</p>		<p>DWG SIZE D</p>	
<p>FINISH</p>		<p>DWG NO</p>		<p>SHT</p>	
<p>CAT NO</p>		<p>REV</p>		<p>REV</p>	