



## EVRC-B Vocoder

Enhanced Variable Rate Codec B

### PRODUCT DESCRIPTION

**Enhanced Variable Rate Codec B (EVRC-B)** is a speech codec used by CDMA (Code Division Multiple Access) networks. EVRC-B is an extension to EVRC and compresses each 20 millisecond FRAMES of 8000 Hz, 16-bit sampled speech input into output frames of one of the four different sizes: Rate 1 - 171 bits, Rate 1/2 - 80 bits, Rate 1/4 - 40 bits, Rate 1/8 - 16 bits. One significant enhancement in EVRC-B is the use of 1/4-rate frames that were not used in EVRC.

The EVRC-B operates at the bit rates 8.3, 7.57, 6.64, 6.18, 5.82, 5.45, 5.08, 4.0kbps (Source encoding rates). The EVRC-B makes use of the intermediate coding rates through increased awareness of the nature of the individual speech samples. This provides lower average data rates compared to EVRC, for a given voice quality.

### FEATURES

- Functions are C-callable.
- Multi-channel capable
- Can be integrated with echo cancellers, and tone detection/regeneration.
- Encodes frames of 20 ms sampled at 8KHz (160 samples) using above algorithms.
- The implementation is **xDAIS/xDM1.0** compliant.
- Mixed C and C55x assembly code implementation
- Bit-exact with all EVRCB 3GPP2 test sequences
- The implementation support run time table relocation
- Fully interruptible Code
- Efficient scratch memory management with reduced stack requirements

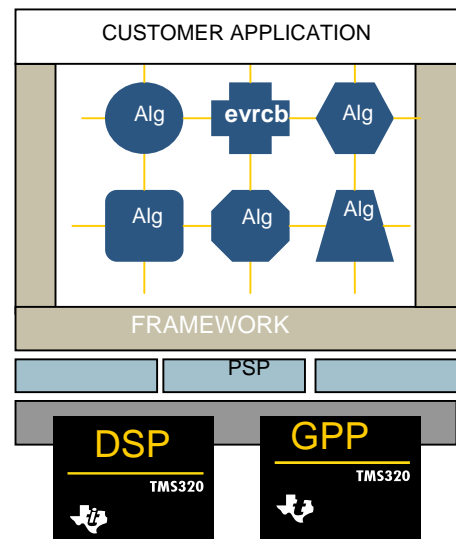

### AVAILABILITY

ADT EVRC-B is available on the TMS3205000™ DSP Family C55x™ DSP Generation



### SPECIFICATIONS

#### C55x

Configuration	ID
Encoder with 20ms framesize	EVRCB_001
Decoder with 20ms frame size	EVRCB_002
Full Duplex	EVRCB_003

**Cycles Information** – Spectrum Digital C5510 DSK

Configuration ID	Performance Statistics (IN MEGACYCLES /SEC) <sup>1</sup>	
	Average	Peak
EVRCB_001	NA	<b>23.10</b>
EVRCB_002	NA	<b>8.10</b>
EVRCB_003	NA	<b>31.20</b>

<sup>1</sup> Measured with all program, constant tables, instance and CDP in SARAM, scratch in DARAM. All performance statistics with DTMF and TTY flags turned off.

**Memory Statistics -**

Configuration	Memory Statistics <sup>2</sup>					Total
	Program MEMORY	Data Memory			Stack	
		Internal	External	SP		
EVRCB_001	83.94	45.81	0	0.51	0.51	130.77
EVRCB_002	53.09	44.46	0	0.4	0.4	98.35
EVRCB_003	118.7	48.19	0	0.51	0.51	167.91

<sup>2</sup> All memory requirements are expressed in kilobytes (1 kilobyte = 1024 8-bit bytes).

**FUNCTIONS***API function call summary*

InitializeEVRC_BencoderChannel (. . .)	Initializes the EVRC-B encoder
InitializeEVRC_BdecoderChannel (. . .)	Initializes the EVRC-B decoder
EncodeEVRC_B (. . .)	Executes the EVRC-B encoder
DecodeEVRC_B (. . .)	Executes the EVRC-B decoder

Adaptive Digital is a member of the Texas Instruments Developer Network, and ARM Connected Community.

## CONTACT INFORMATION

Web: [www.adaptivedigital.com](http://www.adaptivedigital.com)  
 Email: [information@adaptivedigital.com](mailto:information@adaptivedigital.com)  
 Tel: 610.825.0182  
 Toll Free: 1.800.340.2066  
 Fax: 610.825.7616  
 Address: 525 Plymouth Road, Suite 316, Plymouth Woods  
 Plymouth Meeting, PA 19462



**IMPORTANT NOTICE:** Data subject to change, for the most up to date information visit our website. Customers are advised to obtain the most current and complete information about Adaptive Digital products and services before placing orders.

All trademarks are property of their respective owners.

