

---

# AT45DB081D and AT45DB081E Comparison

Adesto Field Application  
<http://www.adestotech.com/>

# AT45DB081D and AT45DB081E Comparison

## Content:

- ❖ Differences Highlight – require software change
- ❖ Features Highlight for AT45DB081E
- ❖ Features not recommended for new design
- ❖ AT45DB081E Command Set Summary
- ❖ Program / Erase Time comparison
- ❖ Feature description
  - ❖ 2-byte Status Register
  - ❖ Enter and exit Ultra-Deep Power Down
  - ❖ Freeze Sector Lockdown
  - ❖ Buffer and Page size reconfiguration
  - ❖ Software Reset
  - ❖ Low Power Read Mode
  - ❖ Program / Erase Suspend and Resume

# AT45DB081E Differences Highlight – Items require Software Change

---

Conversion from AT45DB081D to AT45DB081E

- ✓ Command: No change
- ✓ Product ID: No change
- ✓ Page Program Time: Change from 35msec to 40msec
- ✓ Status Register: No change

# AT45DB081D and AT45DB081E Comparison

AT45DB081E is designed to replace the AT45DB081D in the 8 pin packages. While it maintains the fine granular structure, it also introduces a few new features.







- ✓ Improved Deep Power Down mode – 4.5 $\mu$ A (typical)
- ✓ Ultra-Deep Power Down mode – 400nA
- ✓ Low Power Read mode
- ✓ User configurable and re-configurable page size (256bytes or 264bytes)
- ✓ Program / Erase Suspend and Resume
- ✓ New max operating clock frequency at 104MHz (command 1Bh)
- ✓ Wider operating voltage range: 1.65V – 3.6V
- ✓ Allows Software Reset
- ✓ Now with 5 Bytes Device ID

# AT45DB081D and AT45DB081E Comparison

## AT45DB081D

- Single 2.5V or 2.7V to 3.6V Supply
- RapidS Serial Interface: 66MHz Maximum Clock Frequency
  - SPI Compatible Modes 0 and 3
- User Configurable Page Size
  - 256-Bytes per Page
  - 264-Bytes per Page
  - Page Size Can Be Factory Pre-configured for 256-Bytes
- Page Program Operation
  - Intelligent Programming Operation
  - 4,096 Pages (256/264-Bytes/Page) Main Memory
- Flexible Erase Options
  - Page Erase (256-Bytes)
  - Block Erase (2-Kbytes)
  - Sector Erase (64-Kbytes)
  - Chip Erase (8Mbits)
- Two SRAM Data Buffers (256-/264-Bytes)
  - Allows Receiving of Data while Reprogramming the Flash Array
- Continuous Read Capability through Entire Array
  - Ideal for Code Shadowing Applications
- Low-power Dissipation
  - 7mA Active Read Current Typical
  - 25µA Standby Current Typical
  - 15µA Deep Power Down Typical
- Hardware and Software Data Protection Features
  - Individual Sector
- Sector Lockdown for Secure Code and Data Storage
  - Individual Sector
- Security: 128-byte Security Register
  - 64-byte User Programmable Space
  - Unique 64-byte Device Identifier
- JEDEC Standard Manufacturer and Device ID Read

## AT45DB081E

- Single 1.65V - 3.6V supply  **New**
- Serial Peripheral Interface (SPI) compatible
  - Supports SPI modes 0 and 3
  - Supports RapidS™ operation
- Continuous read capability through entire array  **New**
  - Up to 85MHz
  - Low-power read option up to 10MHz
  - Clock-to-output time ( $t_v$ ) of 6ns maximum
- User configurable page size
  - 256 bytes per page
  - 264 bytes per page (default)
  - Page size can be factory pre-configured for 256 bytes
- Two fully independent SRAM data buffers (256/264 bytes)
  - Allows receiving data while reprogramming the main memory array  **New**
- Flexible programming options
  - Byte/Page Program (1 to 256/264 bytes) directly into main memory
  - Buffer Write
  - Buffer to Main Memory Page Program
- Flexible erase options
  - Page Erase (256/264 bytes)
  - Block Erase (2KB)
  - Sector Erase (64KB)
  - Chip Erase (8-Mbits)
- Program and Erase Suspend/Resume  **New**
- Advanced hardware and software data protection features
  - Individual sector protection
  - Individual sector lockdown to make any sector permanently read-only
- 128-byte, One-Time Programmable (OTP) Security Register
  - 64 bytes factory programmed with a unique identifier
  - 64 bytes user programmable
- Hardware and software controlled reset options
- JEDEC Standard Manufacturer and Device ID Read
- Low-power dissipation
  - 500nA Ultra-Deep Power-Down current (typical)  **New**
  - 3µA Deep Power-Down current (typical)  **New**
  - 25µA Standby current (typical)
  - 11mA Active Read current (typical at 20MHz)

# AT45DB081E Features not recommended for new design

**These commands are supported, but recommended not to use in new design**

Commands	AT45DB081D	AT45DB081E
Buffer 1 Read	54H	54H
Buffer 2 Read	56H	56H
Main Memory Page Read	52H	52H
Continuous Array Read	68H	68H
Status Register Read	57H	57H
Continuous Array Read (Legacy Command – Not Recommended for New Designs)	E8H	E8h

# AT45DB081E Command Set Comparison

Commands	AT45DB081D	AT45DB081E	
Buffer 1 Read (High Frequency)	D4H	D4h	
Buffer 1 Read (Low Frequency)	D1H	D1h	
Buffer 2 Read (High Frequency)	D6H	D6h	
Buffer 2 Read (Low Frequency)	D3H	D3h	
Continuous Array Read (High Frequency)	0BH	0Bh	
Continuous Array Read (High Frequency)		1Bh	← New
Continuous Array Read (Low Frequency)	03H	03h	
Continuous Array Read (Low Power Mode)		01h	← New
Main Memory Page Read	D2H	D2h	
Block Erase	50H	50h	
Buffer 1 to Main Memory Page Program with Built-In Erase	83H	83h	
Buffer 1 to Main Memory Page Program without Built-In Erase	88H	88h	
Buffer 1 Write	84H	84h	
Buffer 2 to Main Memory Page Program with Built-In Erase	86H	86h	
Buffer 2 to Main Memory Page Program without Built-In Erase	89H	89h	
Buffer 2 Write	87H	87h	
Chip Erase	C7H, 94H, 80H, 9AH	C7h + 94h + 80h + 9Ah	← New
Main Memory Byte/Page Program through Buffer 1 without Built-In Erase		02h	← New
Main Memory Page Program through Buffer 1 with Built-In Erase	82H	82h	
Main Memory Page Program through Buffer 2 with Built-In Erase	85H	85h	
Page Erase	81H	81h	
Program/Erase Resume		D0h	← New
Program/Erase Suspend		B0h	← New
Sector Erase	7CH	7Ch	

# AT45DB081E Command Set Comparison

Commands	AT45DB081D	AT45DB081E
Enable Sector Protection	3DH + 2AH + 7FH + A9H	3Dh + 2Ah + 7Fh + A9h
Disable Sector Protection	3DH + 2AH + 7FH + 9AH	3Dh + 2Ah + 7Fh + 9Ah
Erase Sector Protection Register	3DH + 2AH + 7FH + CFH	3Dh + 2Ah + 7Fh + CFh
Program Sector Protection Register	3DH + 2AH + 7FH + FCH	3Dh + 2Ah + 7Fh + FCh
Read Sector Protection Register	32H	32h
Sector Lockdown	3DH + 2AH + 7FH + 30H	3Dh + 2Ah + 7Fh + 30h
Read Sector Lockdown Register	35H	35h
Freeze Sector Lockdown		34h + 55h + AAh + 40h
Program Security Register	9BH + 00H + 00H + 00H	9Bh + 00h + 00h + 00h
Read Security Register	77H	77h
Main Memory Page to Buffer 1 Transfer	53H	53h
Main Memory Page to Buffer 2 Transfer	55H	55h
Main Memory Page to Buffer 1 Compare	60H	60h
Main Memory Page to Buffer 2 Compare	61H	61h
Auto Page Rewrite through Buffer 1	58H	58h
Auto Page Rewrite through Buffer 2	59H	59h
Deep Power-Down	B9H	B9h
Resume from Deep Power-Down	ABH	ABh
Ultra-Deep Power-Down		79h
Status Register Read	D7H	D7h
Configure "Power of 2" (Binary) Page Size	3Dh + 2Ah + 80h + A6h	3Dh + 2Ah + 80h + A6h
Configure Standard DataFlash Page Size		3Dh + 2Ah + 80h + A7h
Software Reset		F0h + 00h + 00h + 00h

New

New

New



# AT45DB081E Command Set Comparison

## AT45DB081E New 5-byte Manufacturer ID

Commands	AT45DB081D	AT45DB081E
Manufacturer and Device ID Read	9FH	9Fh
Manufacturer ID	1Fh	1Fh
Device ID (Byte 1)	25h	25h
Device ID (Byte 2)	00h	00h
[Optional to Read] Extended Device Information (EDI) String Length	00h	01h
[Optional to Read] EDI Byte 1		00h

New

# AT45DB081D and AT45DB081E – Program / Erase Time

Symbol	Parameter	AT45DB081D (2.5V Version)			AT45DB081D			Units
		Min	Typ	Max	Min	Typ	Max	
$t_{EP}$	Page Erase and Programming Time (256-/264-bytes)		14	35		14	35	ms
$t_P$	Page Programming Time (256-/264-bytes)		2	4		2	4	ms
$t_{PE}$	Page Erase Time (256-/264-bytes)		13	32		13	32	ms
$t_{BE}$	Block Erase Time (2,048-/2,112-bytes)		30	75		30	75	ms
$t_{SE}$	Sector Erase Time (65,536/67,584)		0.7	1.3		0.7	1.3	s
$t_{CE}$	Chip Erase Time		7	22		7	22	s

Symbol	Parameter	1.65V to 3.6V			2.3V to 3.6V			Units
		Min	Typ	Max	Min	Typ	Max	
$t_{EP}$	Page Erase and Programming Time (256/264 bytes)		15	40		15	40	ms
$t_P$	Page Programming Time		2	4		2	4	ms
$t_{BP}$	Byte Programming Time		8			8		$\mu$ s
$t_{PE}$	Page Erase Time		12	35		12	35	ms
$t_{BE}$	Block Erase Time		30	75		30	75	ms
$t_{SE}$	Sector Erase Time		.7	1.3		.7	1.3	s
$t_{CE}$	Chip Erase Time		10	20		10	20	s

Max 40ms

Max 35ms

# AT45DB081E – New 2-byte Status Register

## Status Register Read

The 2-byte Status Register can be used to determine the device's ready/busy status, page size, a Main Memory Page to Buffer Compare operation result, the sector protection status, Freeze Sector Lockdown status, erase/program error status, Program/Erase Suspend status, and the device density. The Status Register can be read at any time, including during an internally self-timed program or erase operation.

To read the Status Register, the  $\overline{CS}$  pin must first be asserted and then the opcode D7h must be clocked into the device. After the opcode has been clocked in, the device will begin outputting Status Register data on the SO pin during every subsequent clock cycle. After the second byte of the Status Register has been clocked out, the sequence will repeat itself, starting again with the first byte of the Status Register, as long as the  $\overline{CS}$  pin remains asserted and the clock pin is being pulsed. The data in the Status Register is constantly being updated, so each repeating sequence may output new data. The RDY/ $\overline{BUSY}$  status is available for both bytes of the Status Register and is updated for each byte.

Deasserting the  $\overline{CS}$  pin will terminate the Status Register Read operation and put the SO pin into a high-impedance state. The  $\overline{CS}$  pin can be deasserted at any time and does not require that a full byte of data be read.

Table 9-2. Status Register Format – Byte 2

Bit	Name	Type <sup>(1)</sup>	Description
7	RDY/ $\overline{BUSY}$	R	0 Device is busy with an internal operation.
			1 Device is ready.
6	COMP	R	0 Main memory page data matches buffer data.
			1 Main memory page data does not match buffer data.
5:2	DENSITY	R	1001 8-Mbit
1	PROTECT	R	0 Sector protection is disabled.
			1 Sector protection is enabled.
0	PAGE SIZE	R	0 Device is configured for standard DataFlash page size (264 bytes).
			1 Device is configured for "power of 2" binary page size (256 bytes).

Note: 1. R = Readable only



No change on the first byte

Bit	Name	Type <sup>(1)</sup>	Description
7	RDY/ $\overline{BUSY}$	R	0 Device is busy with an internal operation.
			1 Device is ready.
6	RES	R	0 Reserved for future use.
5	EPE	R	0 Erase or program operation was successful.
			1 Erase or program error detected.
4	RES	R	0 Reserved for future use.
3	SLE	R	0 Sector Lockdown command is disabled.
			1 Sector Lockdown command is enabled.
2	PS2	R	0 No program operation has been suspended while using Buffer 2.
			1 A sector is program suspended while using Buffer 2.
1	PS1	R	0 No program operation has been suspended while using Buffer 1.
			1 A sector is program suspended while using Buffer 1.
0	ES	R	0 No sectors are erase suspended.
			1 A sector is erase suspended.



Note: 1. R = Readable only



# AT45DB081E - Ultra-Deep Power Down

## Ultra-Deep Power-Down

The Ultra-Deep Power-Down mode allows the device to consume far less power compared to the standby and Deep Power-Down modes by shutting down additional internal circuitry. Since almost all active circuitry is shutdown in this mode to conserve power, the contents of the SRAM buffers cannot be maintained. Therefore, any data stored in the SRAM buffers will be lost once the device enters the Ultra-Deep Power-Down mode.

When the device is in the Ultra-Deep Power-Down mode, all commands including the Status Register Read and Resume from Deep Power-Down commands will be ignored. Since all commands will be ignored, the mode can be used as an extra protection mechanism against program and erase operations.

Entering the Ultra-Deep Power-Down mode is accomplished by simply asserting the  $\overline{CS}$  pin, clocking in the opcode 79h, and then deasserting the  $\overline{CS}$  pin. Any additional data clocked into the device after the opcode will be ignored. When the  $\overline{CS}$  pin is deasserted, the device will enter the Ultra-Deep Power-Down mode within the maximum time of  $t_{EUDPD}$ .

The complete opcode must be clocked in before the  $\overline{CS}$  pin is deasserted, and the  $\overline{CS}$  pin must be deasserted on an even byte boundary (multiples of eight bits); otherwise, the device will abort the operation and return to the standby mode once the  $\overline{CS}$  pin is deasserted. In addition, the device will default to the standby mode after a power cycle.

The Ultra-Deep Power-Down command will be ignored if an internally self-timed operation such as a program or erase cycle is in progress. The Ultra-Deep Power-Down command must be reissued after the internally self-timed operation has been completed in order for the device to enter the Ultra-Deep Power-Down mode.

Figure 10-3. Ultra-Deep Power-Down

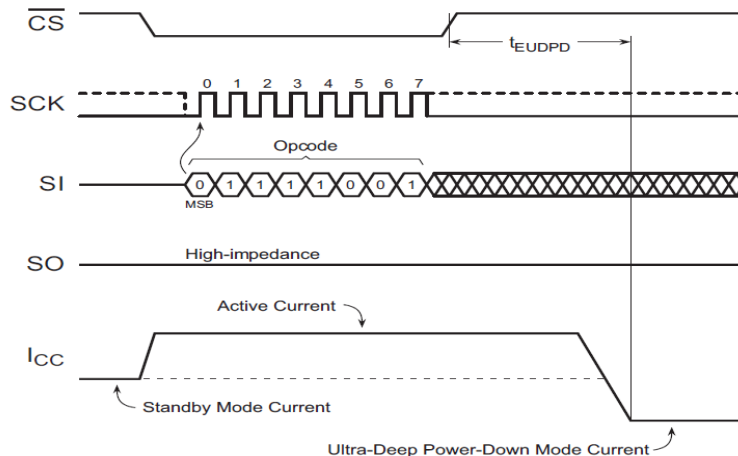

Market Leading  
Ultra-Deep Power Down

- 400nA (typ)
- 1 $\mu$ A (max)



# AT45DB081E - Exit Ultra-Deep Power Down

## Exit Ultra-Deep Power-Down

To exit from the Ultra-Deep Power-Down mode, the  $\overline{CS}$  pin must simply be pulsed by asserting the  $\overline{CS}$  pin, waiting the minimum necessary  $t_{CSLU}$  time, and then deasserting the  $\overline{CS}$  pin again. To facilitate simple software development, a dummy byte opcode can also be entered while the  $\overline{CS}$  pin is being pulsed just as in a normal operation like the Program Suspend operation; the dummy byte opcode is simply ignored by the device in this case. After the  $\overline{CS}$  pin has been deasserted, the device will exit from the Ultra-Deep Power-Down mode and return to the standby mode within a maximum time of  $t_{XUDPD}$ . If the  $\overline{CS}$  pin is reasserted before the  $t_{XUDPD}$  time has elapsed in an attempt to start a new operation, then that operation will be ignored and nothing will be performed. The system must wait for the device to return to the standby mode before normal command operations such as Continuous Array Read can be resumed.

Since the contents of the SRAM buffers cannot be maintained while in the Ultra-Deep Power-Down mode, the SRAM buffers will contain undefined data when the device returns to the standby mode.

Figure 10-4. Exit Ultra-Deep Power-Down

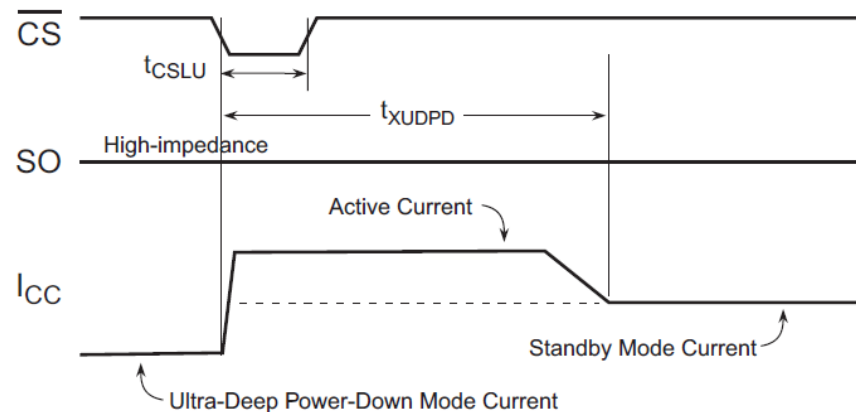

# AT45DB081E – Freeze Sector Lockdown



## Freeze Sector Lockdown

The Sector Lockdown command can be permanently disabled, and the current sector lockdown state can be permanently frozen so that no additional sectors can be locked down aside from those already locked down. Any attempts to issue the Sector Lockdown command after the Sector Lockdown State has been frozen will be ignored.

To issue the Freeze Sector Lockdown command, the  $\overline{CS}$  pin must be asserted and the opcode sequence of 34h, 55h, AAh, and 40h must be clocked into the device. Any additional data clocked into the device will be ignored. When the  $\overline{CS}$  pin is deasserted, the current sector lockdown state will be permanently frozen within a time of  $t_{LOCK}$ . In addition, the SLE bit in the Status Register will be permanently reset to a Logic 0 to indicate that the Sector Lockdown command is permanently disabled.

Figure 8-3. Freeze Sector Lockdown

 Each transition represents eight bits

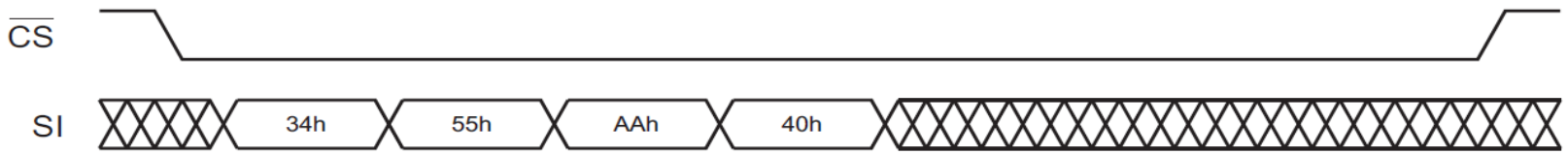



# AT45DB081E – page size re-configuration

Table 11-1. Buffer and Page Size Configuration Commands

Command	Byte 1	Byte 2	Byte 3	Byte 4
“Power of 2” binary page size (256 bytes)	3Dh	2Ah	80h	A6h
DataFlash page size (264 bytes)	3Dh	2Ah	80h	A7h

Figure 11-1. Buffer and Page Size Configuration

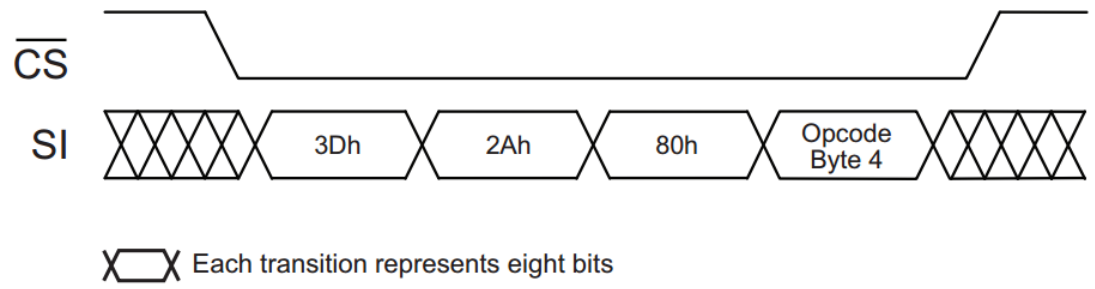

User can reconfigure as needed





# AT45DB081E – Software Reset

## Software Reset

In some applications, it may be necessary to prematurely terminate a program or erase cycle early rather than wait the hundreds of microseconds or milliseconds necessary for the program or erase operation to complete normally. The Software Reset command allows a program or erase operation in progress to be ended abruptly and returns the device to an idle state.

To perform a Software Reset, the  $\overline{CS}$  pin must be asserted and a 4-byte command sequence of F0h, 00h, 00h, and 00h must be clocked into the device. Any additional data clocked into the device after the last byte will be ignored. When the  $\overline{CS}$  pin is deasserted, the program or erase operation currently in progress will be terminated within a time  $t_{SWRST}$ . Since the program or erase operation may not complete before the device is reset, the contents of the page being programmed or erased cannot be guaranteed to be valid.

The Software Reset command has no effect on the states of the Sector Protection Register, the Sector Lockdown Register, or the buffer and page size configuration. The PS2, PS1, and ES bits of the Status Register, however, will be reset back to their default states. If a Software Reset operation is performed while a sector is erase suspended, the suspend operation will abort and the contents of the page or block being erased in the suspended sector will be left in an undefined state. If a Software Reset is performed while a sector is program suspended, the suspend operation will abort and the contents of the page that was being programmed and subsequently suspended will be undefined. The remaining pages in the sector will retain their previous contents.

The complete 4-byte opcode must be clocked into the device before the  $\overline{CS}$  pin is deasserted, and the  $\overline{CS}$  pin must be deasserted on a byte boundary (multiples of eight bits); otherwise, no reset operation will be performed.

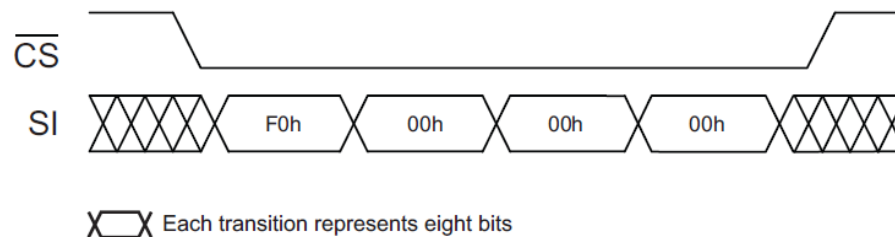



# AT45DB081E – Low Power Read Mode



## Continuous Array Read (Opcode 01h or 03h)

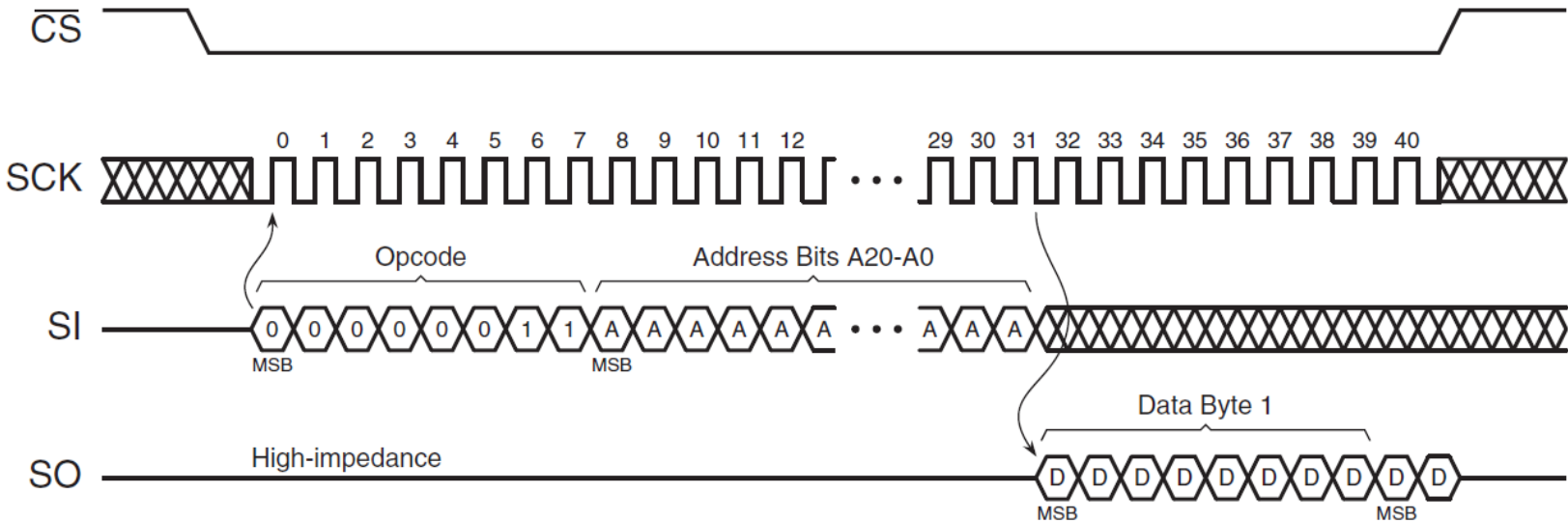

**Lower Read Current:**  
Command 01h:  
6mA typ at 1MHz  
7mA typ at 15MHz

# AT45DB081E – Program / Erase Suspend - Resume



## Program/Erase Suspend

In some code and data storage applications, it may not be possible for the system to wait the milliseconds required for the Flash memory to complete a program or erase cycle. The Program/Erase Suspend command allows a program or erase operation in progress to a particular 128KB sector of the main memory array to be suspended so that other device operations can be performed.

**Example:** By suspending an erase operation to a particular sector, the system can perform functions such as a program or read operation within a different 128KB sector. Other device operations, such as Read Status Register, can also be performed while a program or erase operation is suspended.

## Program/Erase Resume

The Program/Erase Resume command allows a suspended program or erase operation to be resumed and continue where it left off.

Note: Please refer to datasheet for the detail

# DataFlash DataSheets and Samples

---

DataFlash® Datasheet:

<http://www.adeptotech.com/products/serial-flash/dataflash>

DataFlash® Sample Request:

<http://www.adeptotech.com/sample-ordering-information>