

## Low Profile LED Recessed Dome Lamp

### 8051 Series

This ultra slim LED lamp features a low profile design with integrated cooling fins. Protruding less than 3/16" (4.8 mm) below the headliner, the 8051 series frees up valuable headroom space. The unique cast housing design improves cooling performance providing additional light, excellent lumen stability, and longer operational life. With an incredible 1,600 lumens, this unique lamp distributes light evenly and consistently throughout the entire working space.

The 8051 series integrates many features putting it at the top of its class. This lamp is engineered around lighting the entire working area efficiently and consistently, giving the EMTs the exact light they need.

- Wide beam angle for excellent illumination throughout the working area; including cot, floor, and compartments
- The low profile shape moves the LEDs closer to the lens surface to provide increased lighting of upper compartments
- High and low brightness or PWM operation to dim light from high setting
- 4100k color temperature for excellent rendering of skin tones
- Diffused lens for "soft" illuminated appearance
- Ultra low profile, flush mount design; minimum protrusion (3/16" or 4.8 mm) into working area
- Slim pan depth (11/16" or 17.5 mm) allows for more room to run wires, insulation, etc. in the headliner
- Rugged die cast aluminum construction; built-for-life
- Die cast housing with unique styled heat-sinking keeps LEDs running cooler which equals brighter and longer life
- Meets GSA-KKK and NFPA 1917 standards for illuminations
- 5 year warranty

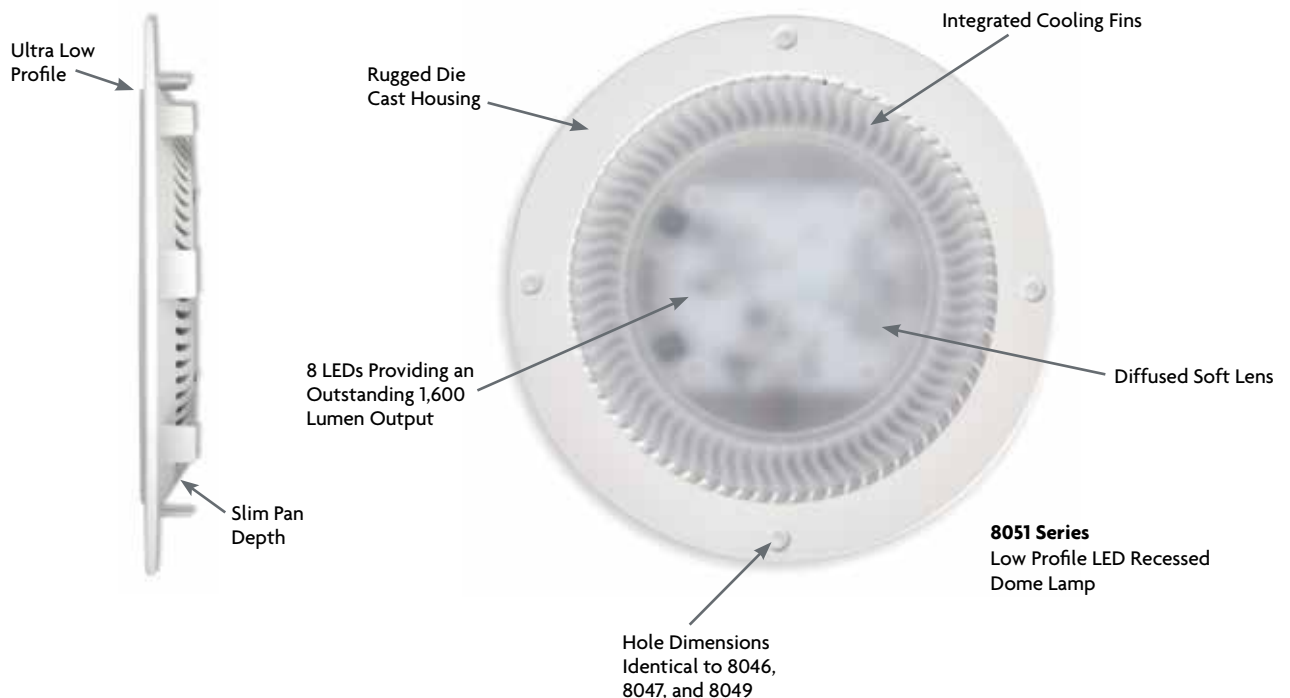

Specifications

- High brightness = 1600 lumens output (25W @ 12v, 21w @ 24v)
- Operates in high/low (patient and check-out functionality)
- PWM dimming capability on high intensity input
- Die cast housing with white powder coat
- Weight: 1.24 lbs. (.56 kg)
- Meets GSA-KKK and NFPA 1917 specifications when properly installed
- Accommodates 8046, 8047 and 8049 hole dimensions

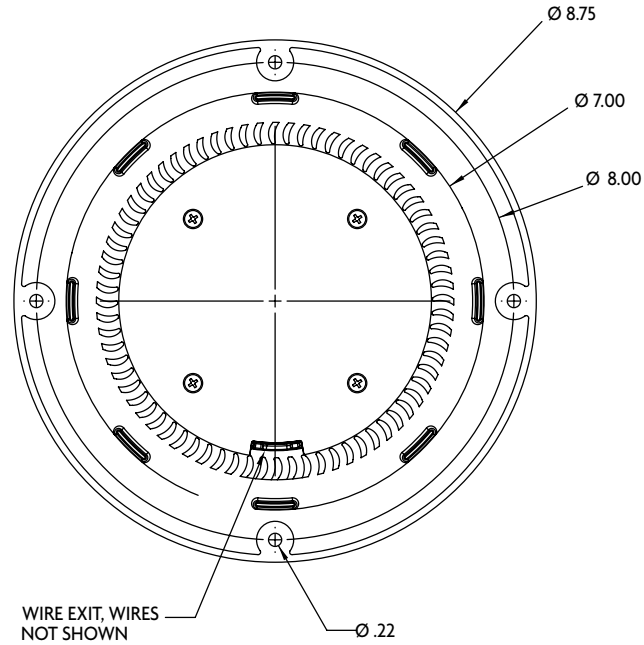
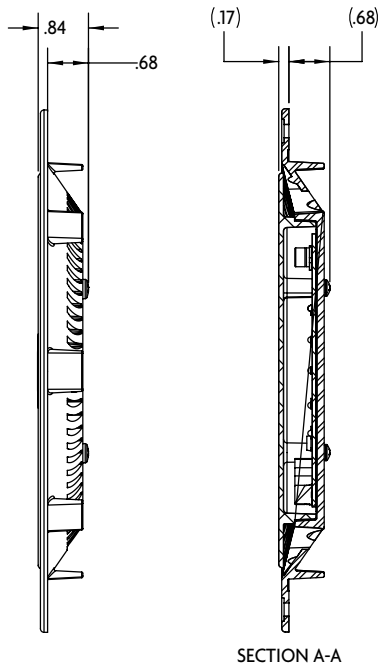
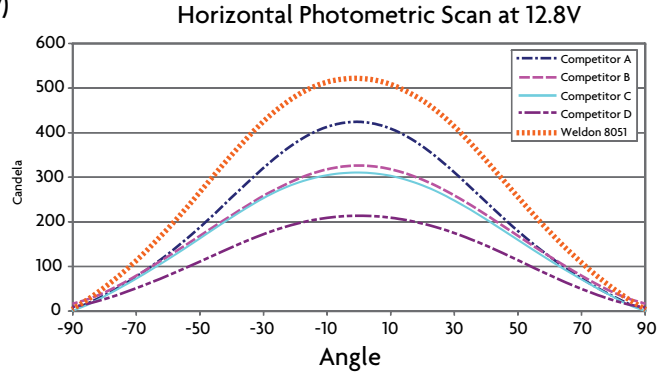

Order Nos.	Description	Amp Draw
8051-0000-30	Low Profile LED Recessed Dome Lamp	High = 2.1A @ 12V, 0.9A @ 24V Low = 0.5A @ 12V, 0.25A @ 24V