

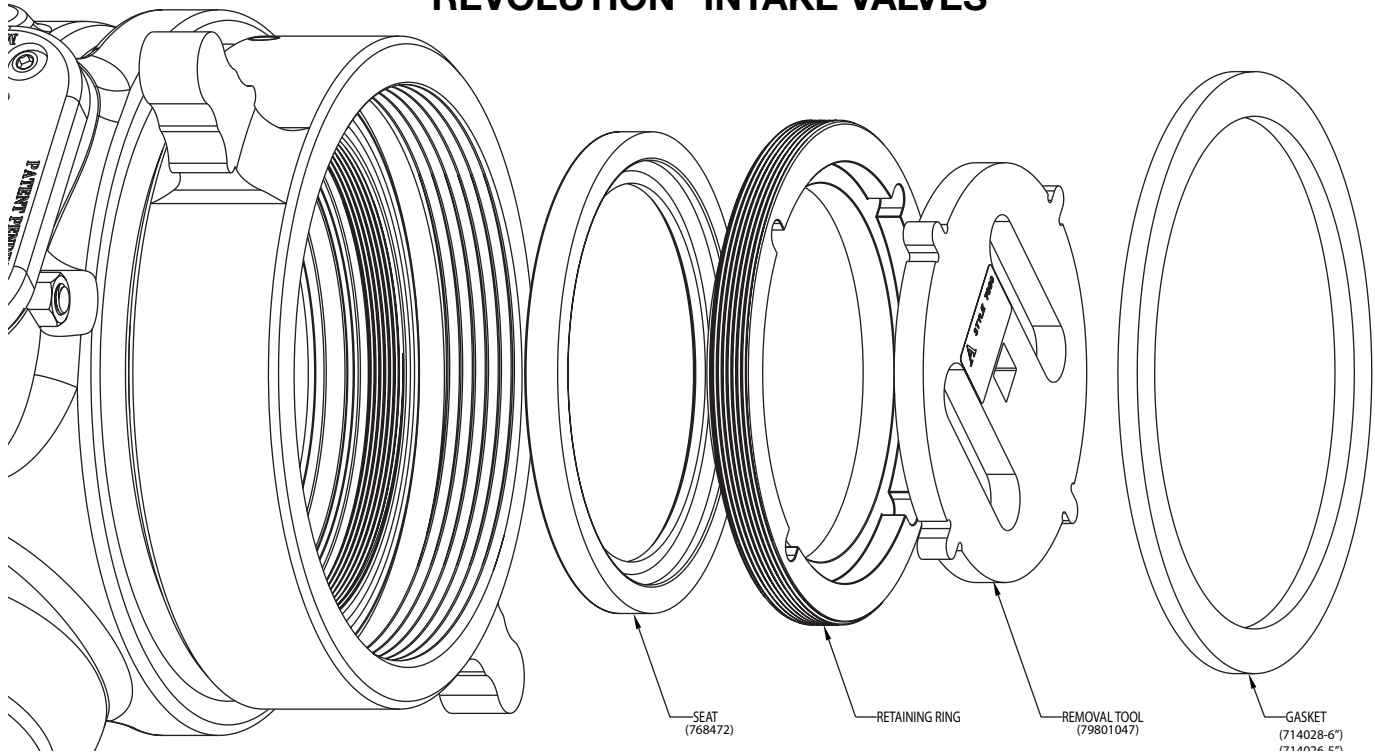

**Style 9169 FIELD SERVICE KIT FOR STYLE 7982 and 7983  
REVOLUTION® INTAKE VALVES**



**Included in the Kit:**

- 768472 – Polymer Replacement Seat
- 714028 – 6" Replacement Gasket

**Tools Required:**

- 79801047 Akron Brass Seat Removal Tool
- 1/2" Ratchet or Breaker Bar
- 1/2" Extension

**Seat Removal:**

1. With the intake valve removed from the apparatus, locate the Retaining Ring which is on the truck side of the intake valve. Remove the old Gasket and discard.
2. Mark the depth and position of the Retaining Ring with respect to the intake assembly (the part the retaining ring is threaded into) with a marker; the ring will need to be tightened to approximately the same depth when reinstalled.
3. With the Intake Valve Ball completely open use the Seat Removal Tool and a 1/2" drive Ratchet or Breaker Bar to remove the Retaining Ring by rotating counter clockwise. Once the Retaining ring is removed, the Seat can be removed from the valve and discarded.

New Seat Installation:

1. Apply (Low-Temp Lubriplate) lubricant grease to the inner diameter of the Seat and to the raised portion on the valve side of the Retaining Ring.
2. Install the new Seat by firmly pressing it into the valve.
3. Using the ½” drive Ratchet, re-install the Retaining Ring into the valve to the depth noted during removal of the old seat.
4. install new gasket.
5. Reinstall, operate valve and test.



PHONE: 330.264.5678 or 800.228.1161 | FAX: 330.264.2944 or 800.531.7335 | [akronbrass.com](http://akronbrass.com)

REVISED: 5/16

WARRANTY AND DISCLAIMER: We warrant Akron Brass products for a period of five (5) years after purchase against defects in materials or workmanship. Akron Brass will repair or replace product which fails to satisfy this warranty. Repair or replacement shall be at the discretion of Akron Brass. Products must be promptly returned to Akron Brass for warranty service.

We will not be responsible for: wear and tear; any improper installation, use, maintenance or storage; negligence of the owner or user; repair or modification after delivery; damage; failure to follow our instructions or recommendations; or anything else beyond our control. WE MAKE NO WARRANTIES, EXPRESS OR IMPLIED, OTHER THAN THOSE INCLUDED IN THIS WARRANTY STATEMENT, AND WE DISCLAIM ANY IMPLIED WARRANTY OF MERCHANTABILITY OR FITNESS FOR ANY PARTICULAR PURPOSE. Further, we will not be responsible for any consequential, incidental or indirect damages (including, but not limited to, any loss of profits) from any cause whatsoever. No person has authority to change this warranty.

© Akron Brass Company. 2015 All rights reserved. No portion of this can be reproduced without the express written consent of Akron Brass Company.