



10/100 BASE-T QUAD PORT SURFACE MOUNT MAGNETICS

- Meets IEEE 802.3af & ANSI X 3.263
- Surface mount, open header construction
- Many parts are PoE enabled
- Standard operating temp: 0°C to +70°C (see footnote)
- Industrial operating temp: -40°C to +85°C (see footnote)

Electrical Specifications @25°C

Part Number	OCL(uH Min) @100KHz,0.2V With 8mA DC Bias	Turns Ratio (±3%)	Insertion Loss (dB Max)	Return Loss (dB Min)			Cross talk (dB Min)		CMMRR (dB Min)	HI-POT (Vrms)
				0.5-100MHz	0.5-30MHz	30.1-60MHz	60.1-80MHz	0.5-40MHz		
AH4001C_	350	1CT:1CT	1.1	18	18-20*log(f/30)	12	35	33-20*log(f/50)	30	1500
AH4002C_	350	1CT:1CT	1.1	18	18-20*log(f/30)	12	35	33-20*log(f/50)	30	1500
AH4005C_	350	1CT:1CT	1.1	18	18-20*log(f/30)	12	35	33-20*log(f/50)	30	1500
AH4007C_	350	1CT:1CT	1.1	18	18-20*log(f/30)	12	35	33-20*log(f/50)	30	1500
AH4008C_	350	1CT:1CT	1.1	18	18-20*log(f/30)	12	35	33-20*log(f/50)	30	1500
AH4009C_	350	1CT:1CT	1.1	18	18-20*log(f/30)	12	35	33-20*log(f/50)	30	1500
AH4010C_	350	1CT:1CT	1.1	18	18-20*log(f/30)	12	35	33-20*log(f/50)	30	1500
AH4011C_	350	1CT:1CT	1.1	18	18-20*log(f/30)	12	35	33-20*log(f/50)	30	1500
AH4012C_	350	1CT:1CT	1.1	18	18-20*log(f/30)	12	35	33-20*log(f/50)	30	1500
AH4013C_	350	1CT:1CT	1.1	18	18-20*log(f/30)	12	35	33-20*log(f/50)	30	1500

*Complete part number by inserting "S" for Standard Temp or "I" for Industrial Temp.

All specifications subject to change without notice.

MECHANICAL

AH4001C_, AH4002C_, AH4005C_, AH4007C_, AH4008C_
 AH4009C_, AH4010C_, AH4011C_, AH4012C_, AH4013C_

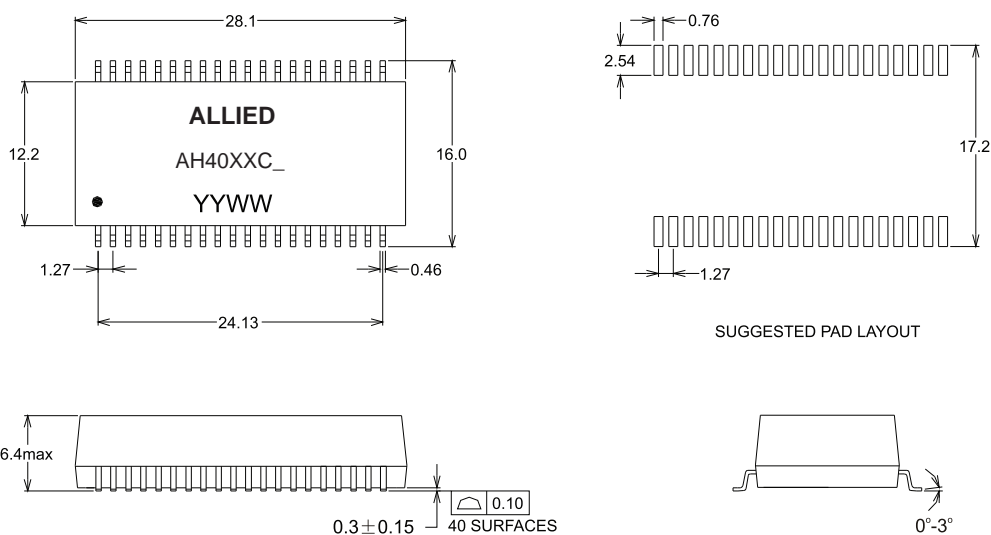

Unless otherwise specified all tolerances are: ±0.25 in mm



10/100 BASE-T QUAD PORT SURFACE MOUNT MAGNETICS

SCHEMATICS

AH4001C_

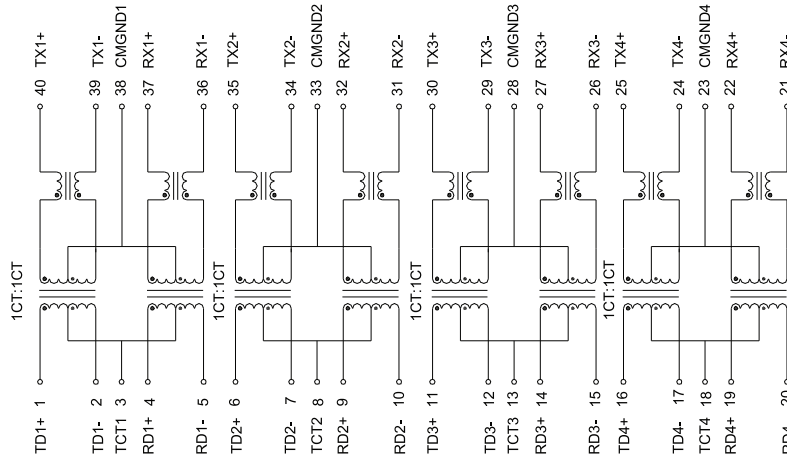

AH4002C_

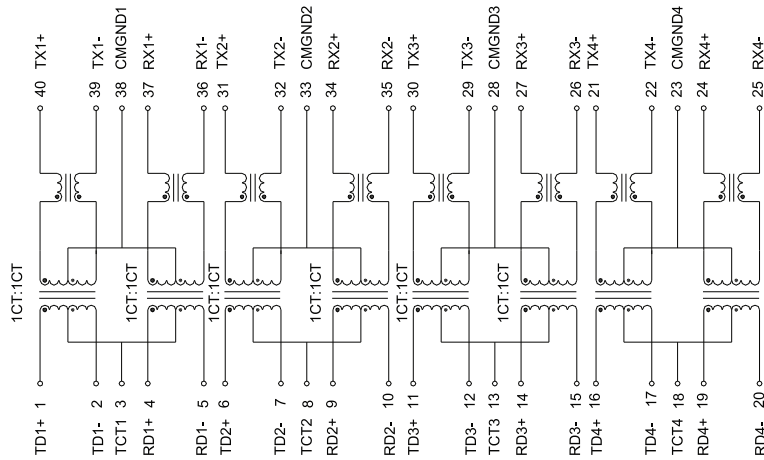

AH4005C_

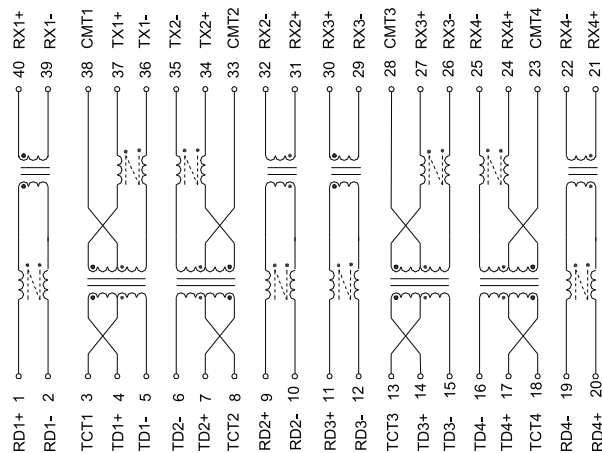



10/100 BASE-T QUAD PORT SURFACE MOUNT MAGNETICS

AH4007C_

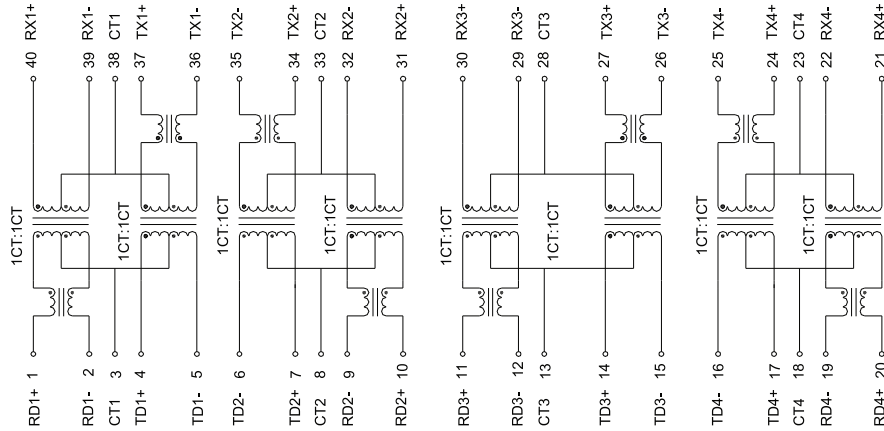

AH4008_

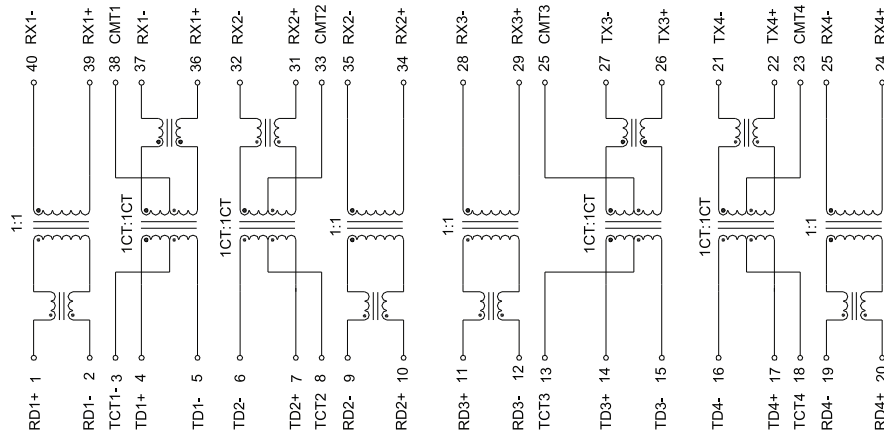

AH4009_

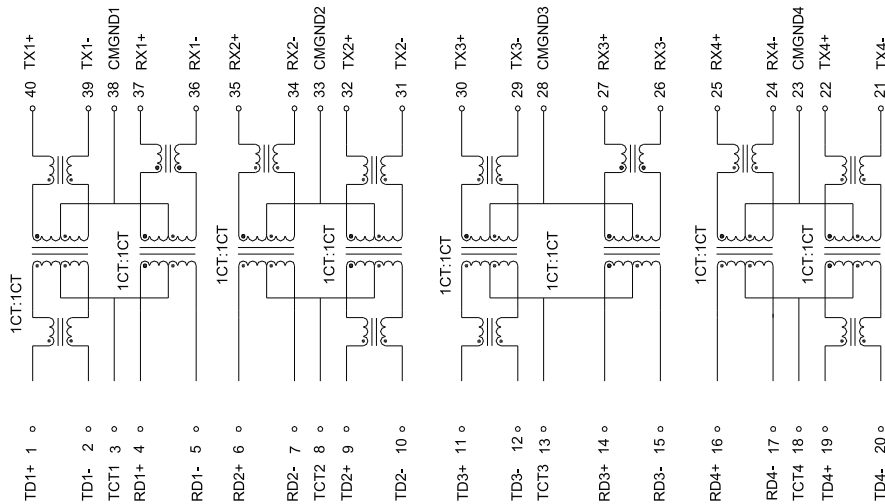

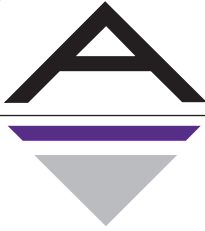

10/100 BASE-T QUAD PORT SURFACE MOUNT MAGNETICS

AH4011C_

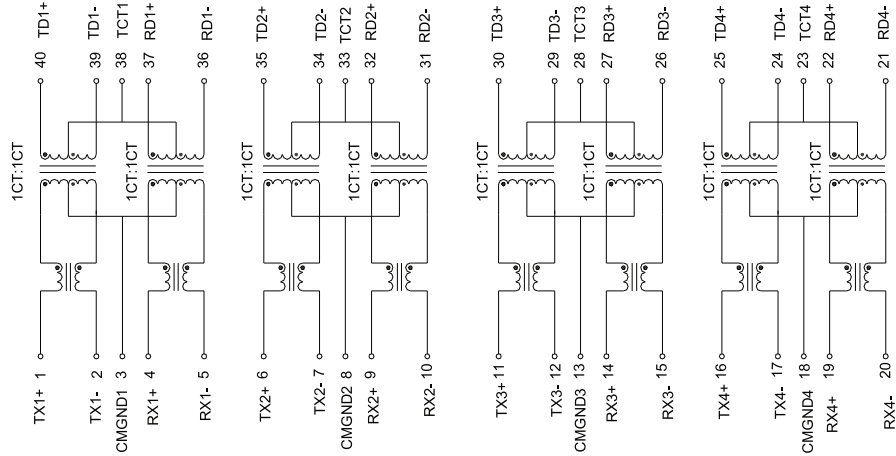

AH4010C_

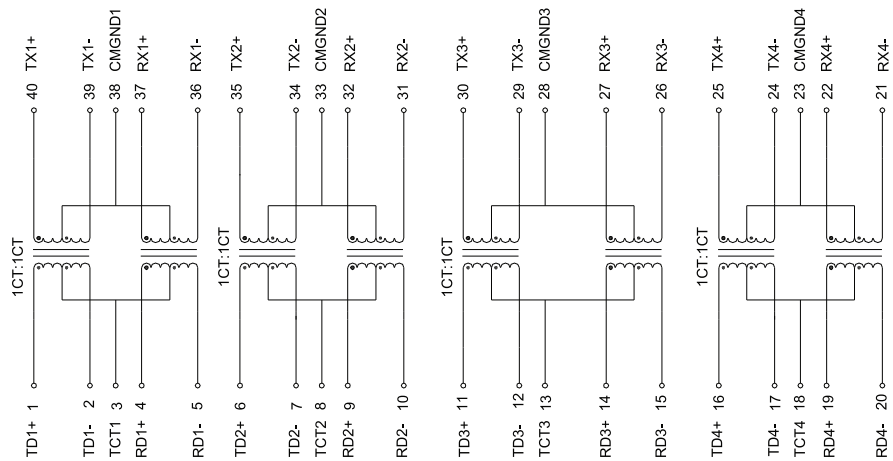

AH4012C_

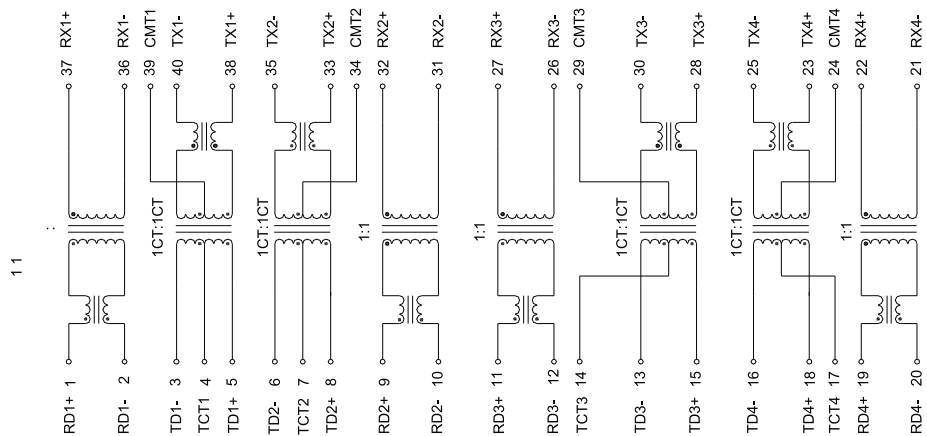



10/100 BASE-T QUAD PORT SURFACE MOUNT MAGNETICS

AH4013C_

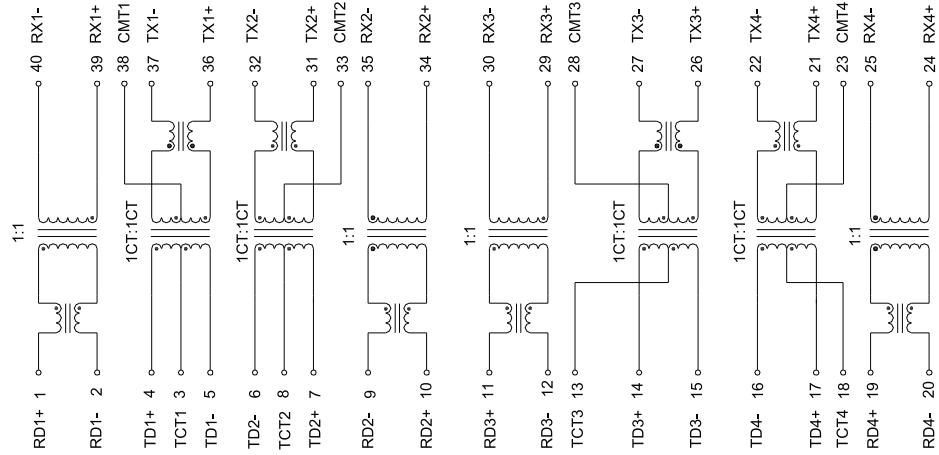

AH4014C_

