

UL 489 Listed, BU series FUJI Molded Case Circuit Breakers

■ UL 489 Listed, C22.2 No.5

- UL File No. E90584 Vol.1c Sec. 2
- CSA certificate No. LR701975

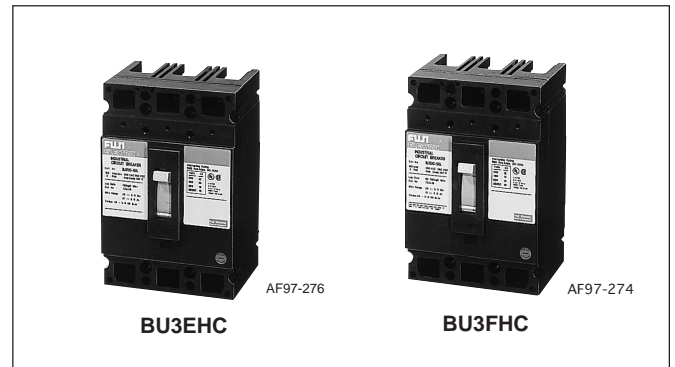

Frame	100A		150A		
Type	BU2EHC	BU3EHC	BU2FHC	BU3FHC	
Pole	2	3	2	3	
Rated insulation voltage (V) (UL 489)	AC	480	480	600	
	DC	250	250	250	
Rated current (A)	15, 20, 25, 30, 35, 40, 45, 50, 60, 70, 80, 90, 100		15, 20, 25, 30, 35, 40, 50 60, 70, 80, 90, 100	15, 20, 25, 30, 35, 40, 50 60, 70, 80, 90, 100, 125, 150	
Rated interrupting capacity (kA)	600V AC	14	18	18	
	480V AC	14	25	25	
	UL489 240V AC	18	65 (125A–150A:42kA)		
	CSA22.2 250V DC	10	20	20	
Dimensions (mm)		a	70	105	105
		b	160	160	160
		c	86	86	86
		d	104	104	104
Tripping device	Thermal-magnetic		Thermal-magnetic		
Tripping button	Provided		Provided		
Auxiliary switch	W	●	●	●	
Alarm switch	K	●	●	●	
Shunt trip	F	–	●	●	
Undervoltage trip	R	●	●	●	
Operating handle *1	V	BU0VFH	BU0VFH		
	N	BU0NFH	BU0NFH		
Terminal cover *2	BZ-CFHB-2	BZ-CFHB-3	BZ-CFHB-3	BZ-CFHB-3	

Notes: ● Factory-mounted optional accessories, specify the type number including optional accessories when ordering.

*1 Customer-mountable optional accessories

*2 For using N type handle: BZ-CFHB-2-N, BZ-CFHB-3-N

For using V type handle: BZ-CFHB-2-V, BZ-CFHB-3-V

• If required insulation barrier, contact FUJI.

UL 489 Listed Molded Case Circuit Breakers

Type number nomenclature

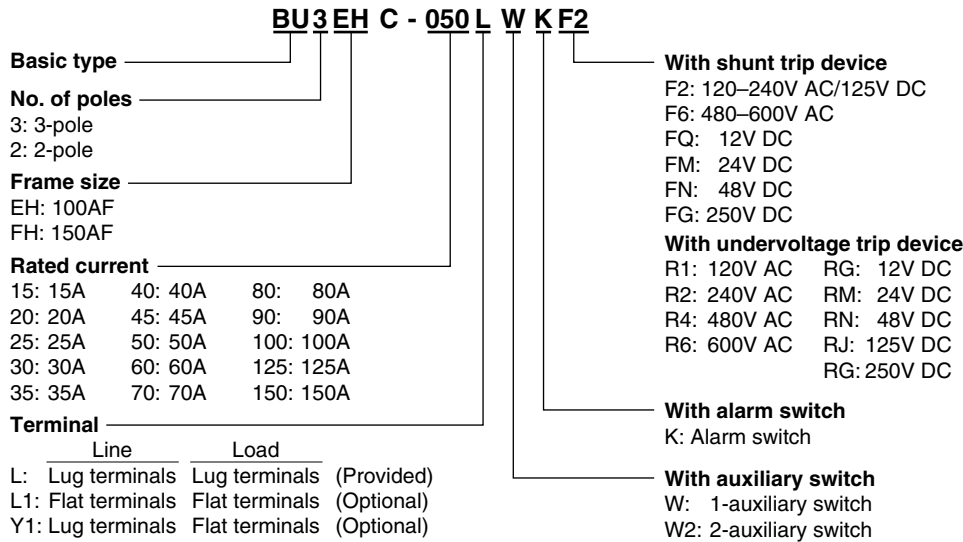

Ordering information

Specify the following:

1. Type number of MCCB including factory-mounted optional accessories
2. Type number customer-mountable optional accessories

Dimensions, mm

BU2EHC

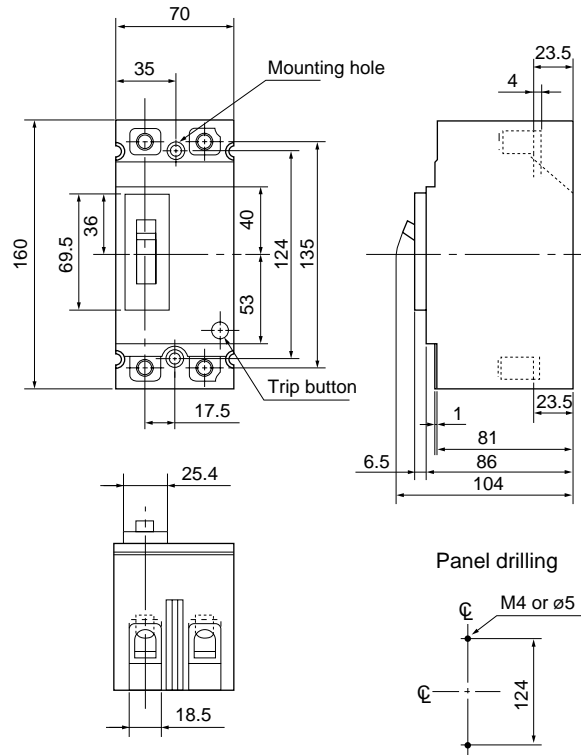

BU2FHC BU3EHC BU3FHC

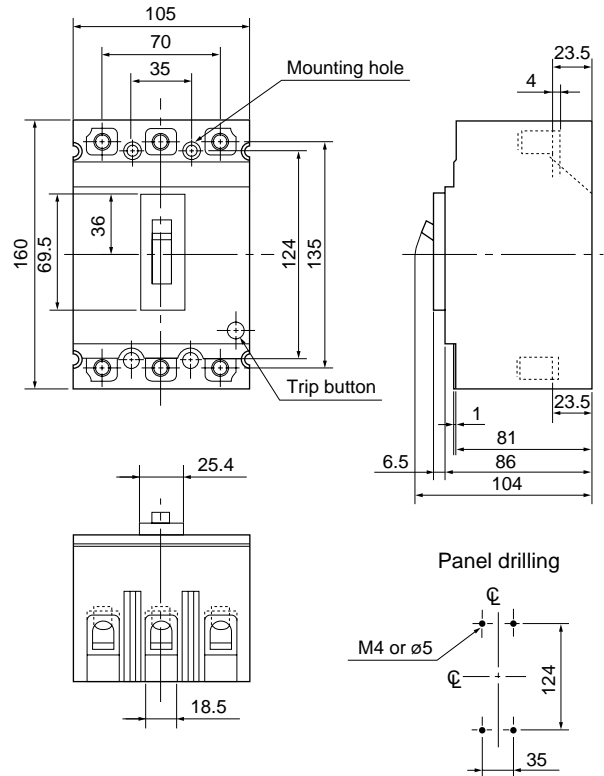

UL 489 Listed Molded Case Circuit Breakers

Characteristic curves

15 to 50A

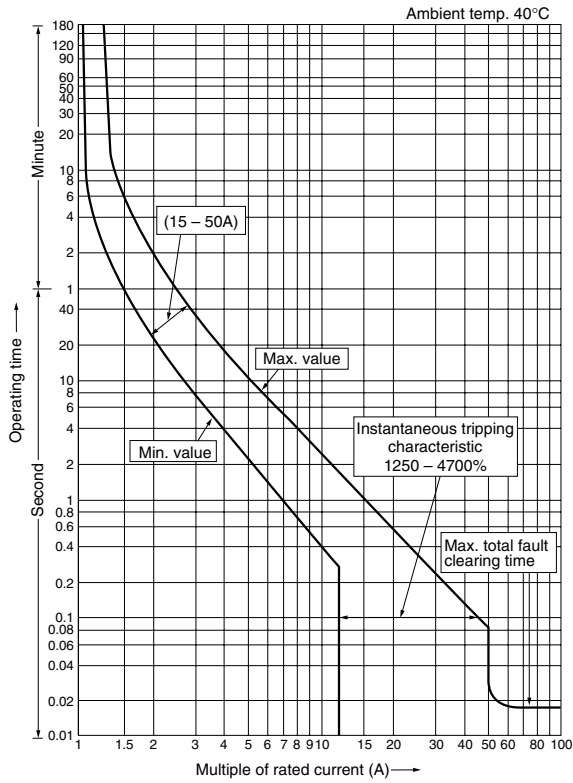

60 to 80A

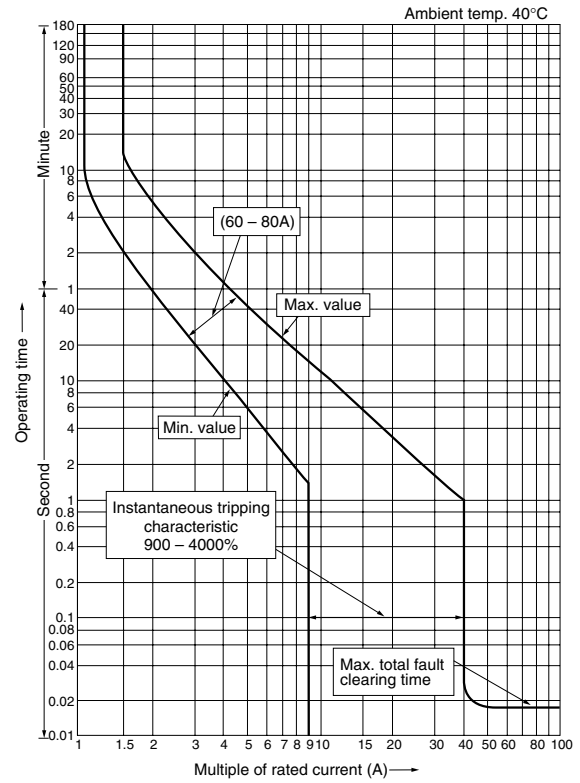

90 to 150A

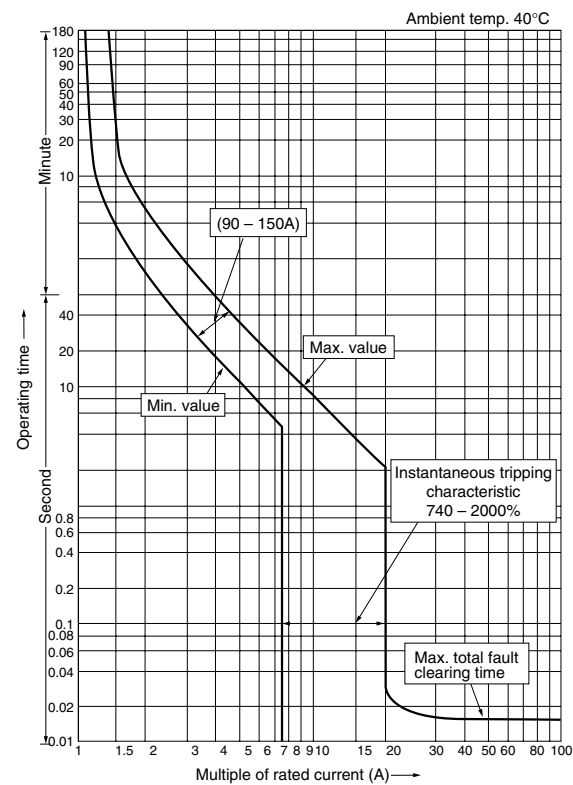

Temperature compensation curve

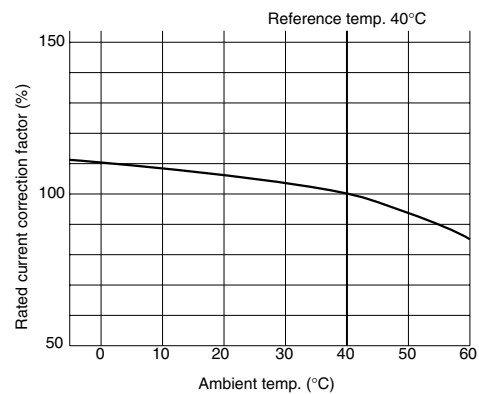

UL 489 Listed Molded Case Circuit Breakers

Optional accessories

Shunt trip devices (F)

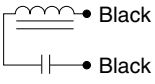
Type	Rated voltage (V)		Inrush current (A)		Wiring
	AC	DC	AC	DC	
F2	120 – 240	125	1.0 – 1.9	1.0	
F6	480 – 600	–	1.5 – 1.9	–	
FQ	–	12	–	7.5	
FM	–	24	–	4.6	
FN	–	48	–	2.4	
FG	–	250	–	0.4	

Undervoltage trip devices (R)

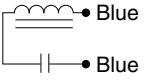
Type	Rated voltage (V)		Rated current (mA)	Wiring
	AC	DC		
R1	120	–	18	
R2	240	–	18	
R4	480	–	18	
R6	600	–	18	
RQ	–	12	200	
RM	–	24	100	
RN	–	48	50	
RJ	–	125	18	
RG	–	250	18	

Auxiliary switches (W)

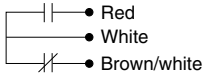
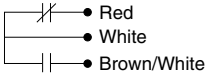
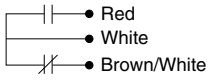
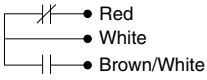
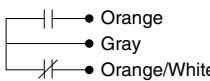
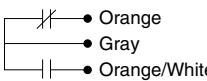
Type		Color of lead wire		Make/break current (A)		
		MCCB/ON	MCCB/OFF, Trip	Voltage	Resistive	Inductive
W	SPDT			120V AC	5	6
				240V AC	–	6
W2	2PDT			125V DC	–	0.5
				250V DC	–	0.25
				120V AC	5	6
				240V AC	–	6
				125V DC	–	0.5
				250V DC	–	0.25

Alarm switches (K)

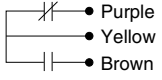
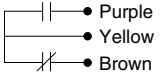
Type		Color of lead wire		Make/break current (A)		
		MCCB/ON	MCCB/OFF, Trip	Voltage	Resistive	Inductive
K	SPDT			240V AC	5	5
				28V DC	5	2.5

Available configurations

Accessory	Type	BU2EHC, BU2FHC		BU3EHC, BU3FHC	
		T	R	T	R
W Auxiliary switch	W	W	W	–	–
K Alarm switch	K	–	–	K	K
F Shunt trip	–	–	F	–	–
R Undervoltage trip	R	R	–	R	R
W2	W2	W2	W2	–	–
WK	–	–	W	–	K
W2K	–	–	W2	–	K
WF	–	–	F	–	W
W2F	–	–	F	–	W2
WR	–	–	W	–	R
W2R	–	–	W2	–	R
KF	–	–	F	–	K
KR	–	–	–	–	–
WKF	–	–	–	–	–
WKR	–	–	–	–	–

Note: Lead wiring

UL 489 Listed Molded Case Circuit Breakers

■ Dimensions, mm

V type operating handle/BU0VFH

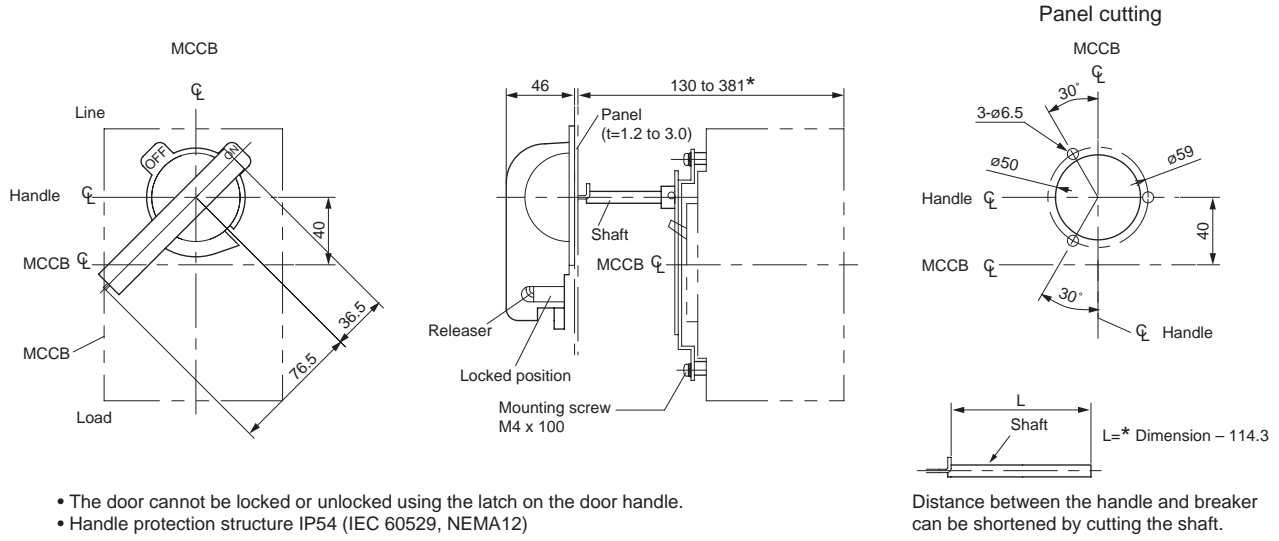

N type operating handle/BU0NFH

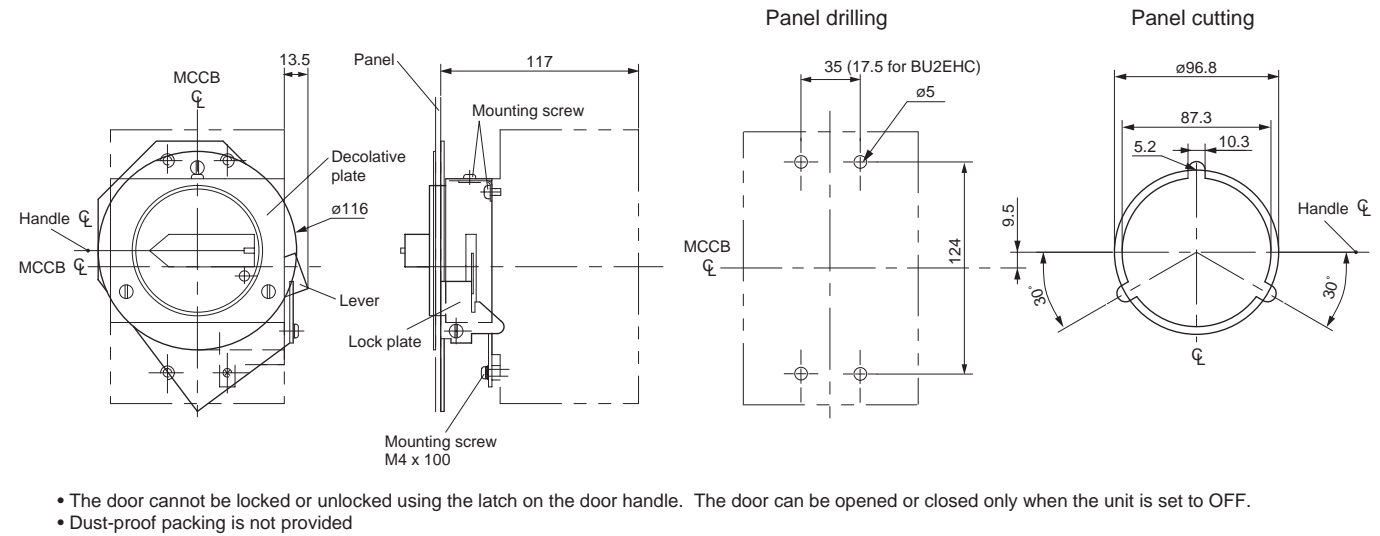

UL 489 Listed Molded Case Circuit Breakers

■ Wire connection

1. Make sure that no voltage is applied to the breaker.
2. Connect the breaker in the direction shown in Figure 1 so that the ON mark is on the line side and the OFF mark is on the load side.

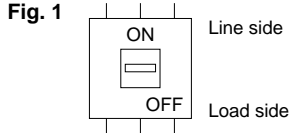

3. The connections of wires must conform to the U.S. National Electric Code (NEC) or the Canadian Electrical Code Part 1 (CEC).
4. For connection, use 60°C copper wire (15A to 125A) or 75°C copper wire only. The use of UL-certified or CSA-certified wire is recommended.
5. As the occurrence of a short circuit current could result in the generation of a large electromagnetic force between wires, be sure to firmly support the wires.
6. Periodically retighten the terminal screws. Do not block the arc gas exhaust.

Lug terminals

1. Table 1 lists the sizes of connectable wires. Use wires within this range.
2. The twist count for the wire must conform to Table 1. Multicore wires cannot be used.
3. Two different types of wires cannot be connected to the lug terminal together.
4. Do not solder the wire.
5. Use the tightening torque listed in Table 1 when securing the wire.

Flat terminals

1. Order insulating barriers (interphase barriers).
2. Insulate the terminal part.

Table 1 Max. wire sizes and tightening torque

Rated current	Applicable lug terminal	Wire size	Tightening torque	Screw size
15A max.	BU0L12HF	14AWG (2.1mm ²)	512N•cm	Slotted head screw
20A		12AWG	45Lb-in	
25A, 30A		10AWG		
35A–50A		8AWG		
60A		6AWG	623N•cm	
70A, 80A	BU0L12AHF	4AWG	55Lb-in	
90A		3AWG		
100A	BU0L15HF	3AWG		
110A		2AWG		
125A		1AWG		
150A			1/0AWG (53.5mm ²)	

■ Mounting

Avoid mounting this breaker in an environment exposed to vibration, shock, dust, or excessive humidity. Secure the insulation distance between a board and the line side of the breaker as shown in Figure 2 and Table 2.

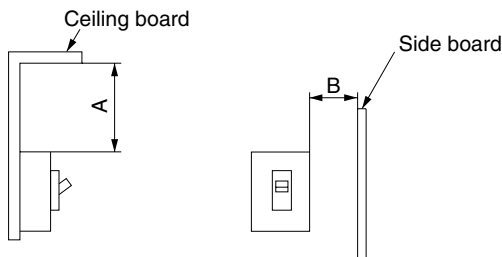

Fig. 2 Insulation distance (line side)

Table 2 Insulation distance (line side)

[Unit: mm]

Breaker type	Dimension A Breaker to ceiling board	Dimension B Breaker to side board
BU□EHC	100	25
BU□FHC	100	25

Safety Considerations

- For safe operation, before using the product read the instruction manual or that comes with the product carefully or consult the Fuji sales representative from which you purchased the product.
- Some of the products listed in this catalog may have limits on their use or location or may require periodic inspections. Contact Fuji's sales representative for further information.
- For safe operation, wiring should be conducted only by qualified engineers who have sufficient technical knowledge about electrical work or wiring.

Fuji Electric Co., Ltd.

ED & C • Drive Systems Company

Gate City Ohsaki, East Tower

11-2, Osaki 1-chome, Shinagawa-ku, Tokyo, 141-0032, Japan

Phone: +81-3-5435-7132

Fax: +81-3-5435-7473

URL <http://www.fujielectric.co.jp/eng/index.html>



Printed on 100% recycled paper