

SO162005A

 Variable Frequency Control for Single-Phase
 AC Induction Motors

Delivering 650W/6.5A at 115V to control 1/2hp 60Hz single-phase motors

General Description

Anacon's adaptable AC motor controller system, DigiDrive™II, offers a wide range of standard modules, which are easily configured to match OEM and end user specifications. The DigiDrive™II satisfies most single-phase motor control applications with a cost-effective solution, which carries the necessary agency approvals, resulting in a much shorter "time to market." Other available motor power ratings are 1/4 hp, 1/3 hp and 3/4 hp.

The overall system is divided into three modules: the power interface, the power drive block and the control interface; each is responsible for providing the overall functionality within the system.

This approach results in the following benefits:

- Optimized product for each application
- Cost-effective, even in low volumes
- Rapid time to market
- Control parameters configured by PC
- Agency pre-approved designs
- Field-tested software designs
- Energy-saving solution
- Isolated control input options of 0 - 5V_{DC} and 4 - 20 mA

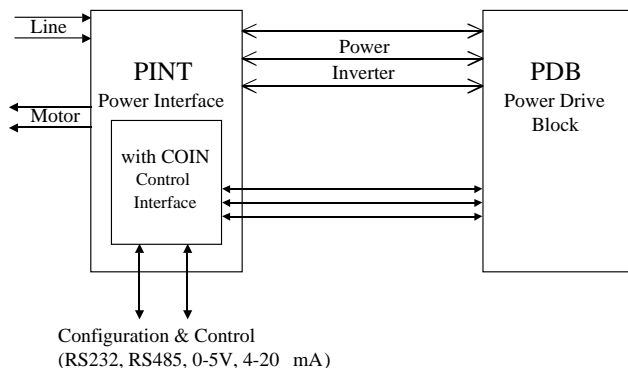

Figure 1
 Functional Block Diagram

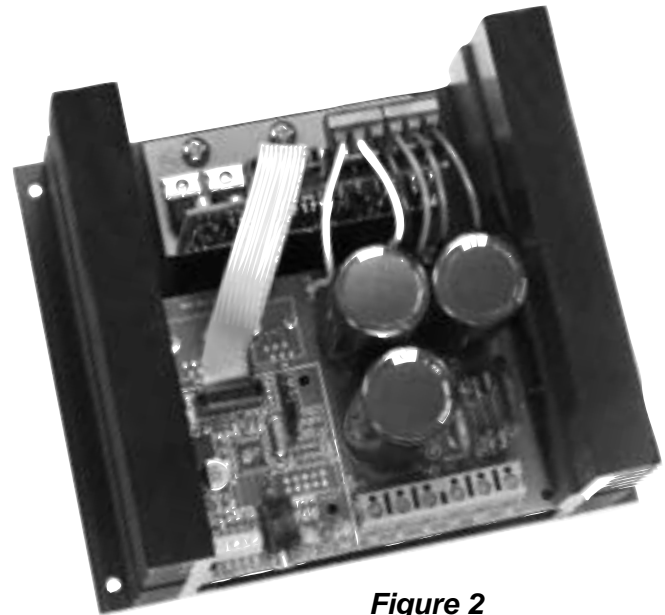

Figure 2
 SO162005A Motor Controller

Architectural Overview

Two modules comprise the motor control system: the combined Power Interface Board (PINT) and the Control Interface (COIN) and the Power Drive Block (PDB). The SO162005A has the Control Interface (COIN) integrated onto the PINT module. The complete controller is shown in Figure 2.

The PINT processes the incoming 115VAC power to make it suitable for powering the PDB. The COIN provides the vital two-way link between the control signals, monitoring equipment and the PDB.

The PDB produces all switching waveforms required to energize the motor.

Drive options include: speed pot, enclosure and configuration kit (Windows™ based) for drive customization.

Electrical Characteristics

Definition	Symbol	Min	Typ	Max	Units	Notes
Input Voltage (RMS)	V_{IN}	105	115	130	V_{AC}	Single Phase
Input Current (RMS)	I_{IN}		$1.25I_O$	8.2	A	100% load
Input Frequency	f_{IN}	45		65	Hz	
Power Factor	PF		0.65			At max rated P_O
Output Power (RMS)	P_O			650	W	$V_{IN} = 115VAC$
Motor Ratings	P_M			0.5	hp	Motor Efficiency = 70%
Efficiency	%		93		%	At max rated P_O
Overload Capacity	%			150	%	For up to 10 seconds
Output Voltage (RMS)	V_O			V_{IN}	V_{AC}	Function of frequency
Output Current (RMS)	I_O		6.5A		A	
Output Current Limit	I_L			110	%	Firmware configurable
Startup Current Boost	I_B			150	%	
Output Frequency	f_O	5		128	Hz	Configurable Range
Output Frequency	f_O	20		65	Hz	Default Range
Frequency Resolution	f_{RES}		1.0		Hz	
PWM Switching Freq.	f_{PWM}		18		kHz	
PWM dV/dt	V_R		450		V/ μ s	With Filter
Ramp Up Times	t_{RU}	1		50	Hz/s	Configurable
Ramp Down Times	t_{RD}	1		50	Hz/s	Configurable
Input Speed Control	V_{CNTRL}	0		5	V_{DC}	
Motor Lead Length	L			2	m	
Operating Lifetime	t_{life}		20,000		hrs	Av. $P_O = 0.5P_{O(max)}$; C@70°C
Ambient Operating Temp.	T_a	0	25	40	°C	>40°C half lifetime per +10°C
Ambient Storage Temp.	T_{STG}	0	25	65	°C	
Humidity Range	H	0	60	95	%	Non-condensing

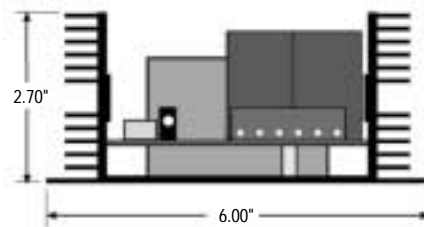
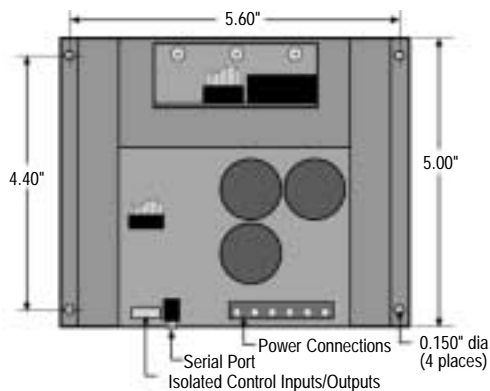

For assistance call 888-456-3398

E-mail: info@anaconsystems.com Web Site: www.anaconsystems.com



U.S. Sales & Application Center: 9433 Bee Cave Road, Bldg. 1, Suite 140, Austin, TX 78733 Tel: (512)263-8668 - Fax (512)263-8060
 Corporate Headquarters: 1043 Shoreline Boulevard, Suite 202, Mountain View, CA 94043 USA - Tel: (650)934-3355 - Fax: (650)934-3356