

## Type 1009 4½" & 6" Stainless Steel Gauge



- 4½" and 6" stainless steel gauges
- Dry and liquid-filled versions
- Micrometer adjustable pointer
- Variety of Bourdon tube materials
- ASME Grade 1A, ±1% of span accuracy
- New PLUS!™ Performance Option:
  - Liquid-filled performance in a dry gauge
  - Fights vibration and pulsations with out liquid-fill headaches
  - Order as option XLL

The 4½" and 6" Ashcroft® Type 1009 gauges are suitable where ambient corrosion is a major concern. Its attractive stainless steel case and ring provides excellent resistance to chemical, weather and corrosion attack. This 1009 has many optional features that allow a user to develop a basic or special product specification. The 1009 is part of the extensive line of Ashcroft stainless steel pressure gauges.

The gauge is available dry, liquid-filled weatherproof or hermetically sealed and now with PLUS!™ Performance option.

### PRODUCT SPECIFICATIONS

<b>Model Number:</b>	1009
<b>Accuracy:</b>	1% full scale (Grade A, ASME B40.100)
<b>Ranges:</b>	Vacuum – 30,000 psi
<b>Dial Size:</b>	4½" and 6" diameter
<b>Case:</b>	Open front
<b>Case Material:</b>	304 SS
<b>Weather Protection:</b>	Dry Case: IP54 Liquid filled or hermetically sealed case: IP 65
<b>Ring Type:</b>	304 SS, bayonet
<b>Window:</b>	Glass
<b>Dial:</b>	Aluminum, white background, black figures and graduations.
<b>Pointer:</b>	Micrometer adjustable
<b>Movement:</b>	400 SS (conventional)
<b>Bourdon Tube and Socket:</b>	Bronze/Brass (A) <sup>(1)</sup> 316L SS/316L SS (S) <sup>(2)</sup> Monel/Monel (P) <sup>(2)</sup>
<b>Connection Size:</b>	¼", ½" NPT
<b>Connection Location:</b>	Lower and back

### PRODUCT OPTIONS

<b>PLUS! Performance:</b>	XLL
<b>Fill:</b>	L-Glycerin-Standard XGV-Silicone-Optional XGX-Halocarbon-Optional

<b>Weatherproof</b>	
<b>Hermetic Seal:</b>	XLJ
<b>Panel Mount</b>	
<b>Front Flange:</b>	XFF
<b>Panel Mount</b>	
<b>U-Clamp:</b>	XUC
<b>Surface Mount:</b>	XBF
<b>Oxygen Clean:</b>	X6B
<b>Window</b>	
<b>Acrylic:</b>	XPD
<b>Shatterproof</b>	
<b>Glass:</b>	XSG

<sup>(1)</sup> Joints silver brazed

<sup>(2)</sup> Joints welded

### TEMPERATURE LIMITS

	Ambient	Process	Storage
Dry	-20/200°F (-29/93°C)	-20/250°F <sup>(1)</sup> (-29/121°C)	-40/250°F (-40/121°C)
LF (glycerin)	20/150°F (7/66°C)	20/200°F (7/93°C)	0/150°F (-18/66°C)
(silicone)	-40/150°F (-40/66°C)	-40/200°F (-40/93°C)	-40/150°F (-40/66°C)
(halocarbon)	-40/150°F (-40/66°C)	-40/200°F (-40/93°C)	-40/150°F (-40/66°C)

**Note:** Other than discoloration of the dial and hardening of the gasketing that may occur as ambient or process temperatures exceeds 150°F, non-liquid-filled gauges with standard glass windows, can withstand continuous operating temperatures up to 250°F (121°C). Liquid-filled gauges can withstand 200°F (93°C) but glycerin fill and acrylic window will tend to yellow. Accuracy at temperatures above or below the reference ambient temperature of 68°F will be affected by approximately .4% per 25°F. Gauges with welded joints will withstand 750°F (450°F (232°C) with silver brazed joints) for short times without rupture, although other parts of the gauge will be destroyed and calibration will be lost. For continuous use and for process or ambient temperatures above 250°F (121°C), a diaphragm seal or capillary or siphon is recommended.

### 45/60 1009 GAUGE PRODUCT CODING

Typical Code:

45	1009	S	L	04	L	XSG	100#	
SIZE	TYPE NUMBER	SYSTEM (Tube & Socket)	CASE DESIGN	PROCESS CONN. SIZE	CONNECTION LOCATION	VARIATIONS	RANGE	ENGINEERING UNITS <sup>(1)</sup>
(45) 4½ (60) 6	1009	Code (A) Phos Brz <sup>(2)</sup> (S) AISI 316SS <sup>(2)</sup> (P) K Monel <sup>(2)</sup> (1) To 1000 psi (2) To 30,000 psi	Code (L) Liquid Filled (glycerin std.)	Code (02) ¼ Male <sup>(1)</sup> (04) ½ Male <sup>(1)</sup> (09) ¾-18 UNF-2B Aminco (standard for high pressure >20,000 psi) (1) Max Pressure 20,000 psi	Code (L) Lower (B) Back (D) Side Conn. (E) Side Conn. (T) Top	(GV) Silicone Case Fill (GX) Halocarbon Case Fill (NH) SS Wired Tag (TS) Throttle Screw <sup>(1)</sup> (6B) Oxygen Service (PD) Acrylic Window <sup>(1)</sup> (SG) Safety Glass (LJ) Hermetically Sealed Liquid Fillable (IP65) (EP) Maximum Pointer, Adjustable (SH) Red Set Hand, Stationary (LL) PLUS! Performance (56) Flush Mounting Ring (C4) Individual Calibration Chart (1) Standard with hermetically sealed or liquid filled gauge.	15 30 60 100 160 200 300 400 600 1000 1500 2000 3000 5000 6000 10,000 20,000 30,000	(#) PSI (BR) Bar (KG) Kilograms/ CM <sup>2</sup> (KP) Kilopascal (IMV) Inches of Mercury (1) See website for more units of measure



# Type 1009 4½" & 6" Stainless Steel Gauge

## DIMENSIONS

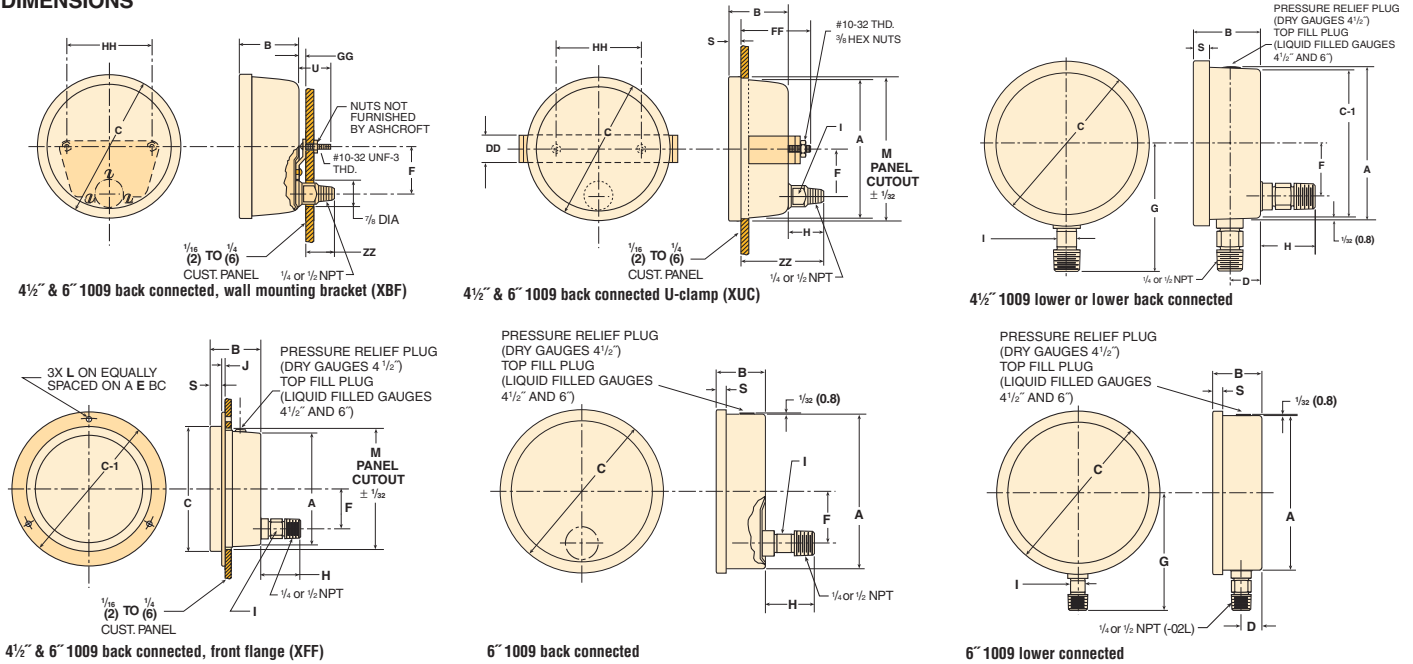

Gauge Size	A	B	C	C-1	D	DD	E	F	FF	G	GG	H	HH	I	J	L	M	S	U	ZZ	Weight		
	(100)	(120)	(52)	(129)	(160)	(24)	(25)	(144)	(41)	(59)	(100)	(5)	(41)	(76)	(16)	(4)	(6)	(122)	(12)	(37)	(83)	Dry	LF
4½	4 <sup>23</sup> / <sub>32</sub>	2 <sup>1</sup> / <sub>16</sub>	5 <sup>3</sup> / <sub>32</sub>	6 <sup>9</sup> / <sub>32</sub>	1 <sup>5</sup> / <sub>16</sub>	1	5 <sup>11</sup> / <sub>16</sub>	1 <sup>5</sup> / <sub>8</sub>	2 <sup>5</sup> / <sub>16</sub>	3 <sup>15</sup> / <sub>16</sub>	3 <sup>1</sup> / <sub>16</sub>	1 <sup>5</sup> / <sub>8</sub>	3	5 <sup>5</sup> / <sub>8</sub>	5 <sup>3</sup> / <sub>32</sub>	7 <sup>3</sup> / <sub>32</sub>	4 <sup>13</sup> / <sub>16</sub>	1 <sup>5</sup> / <sub>32</sub>	1 <sup>7</sup> / <sub>16</sub>	3 <sup>9</sup> / <sub>32</sub>	1.75#	2.40#	
6	6 <sup>5</sup> / <sub>16</sub>	2	6 <sup>21</sup> / <sub>32</sub>	7 <sup>5</sup> / <sub>8</sub>	2 <sup>7</sup> / <sub>32</sub>	1	7 <sup>1</sup> / <sub>32</sub>	1 <sup>5</sup> / <sub>8</sub>	2 <sup>5</sup> / <sub>8</sub>	4 <sup>13</sup> / <sub>16</sub>	3 <sup>1</sup> / <sub>16</sub>	1 <sup>5</sup> / <sub>8</sub>	4 <sup>1</sup> / <sub>2</sub>	5 <sup>5</sup> / <sub>8</sub>	1 <sup>1</sup> / <sub>16</sub>	1 <sup>1</sup> / <sub>4</sub>	6 <sup>7</sup> / <sub>16</sub>	1 <sup>13</sup> / <sub>32</sub>	1 <sup>7</sup> / <sub>16</sub>	3 <sup>3</sup> / <sub>16</sub>	2.25#	4.12#	
	(160)	(160)	(51)	(169)	(194)	(22)	(25)	(179)	(41)	(67)	(122)	(5)	(41)	(114)	(16)	(2)	(7)	(163)	(10)	(37)	(81)	1kg	1.85kg

Note: Dimensions in brackets ( ) are millimeters.

## Standard Ranges (Metric equivalents available)

Pressure - psi			
Range	Figure Interval		Minor Graduation
0/15	1		0.1
0/30	5		0.2
0/60	5		0.5
0/100	10		1
0/160	20		2
0/200	20		2
0/300	50		2
0/400	50		5
0/600	50		5
0/800	100		10
0/1000	100		10
0/1500	200		20
0/2000	200		20
0/3000	500		20
0/5000	500		50
0/6000	500		50
0/10,000	1000		100
0/20,000	2000		200
0/30,000	5000		200

Compound				
Range	Figure Interval		Minor Grads	
	in Hg	psi	in Hg	psi
30" Hg/15 psi	5	3	0.5	0.2
30" Hg/30 psi	10	5	1	0.5
30" Hg/60 psi	10	10	1	1
30" Hg/100 psi	10	10	2	1
30" Hg/150 psi	10	20	5	2
30" Hg/200 psi	30	20	5	2
30" Hg/300 psi	30	50	5	2

Vacuum		
Range	Figure Interval	Minor Grads
30/0 in. Hg	5 in	0.2 in
34/0 ft H <sub>2</sub> O	5 ft	0.5 ft