

**Installation and Maintenance Instructions for  
B700 ASHCROFT® Snap Action Switches  
ATEX Directive 94/9/EC EEx d IIC T6;  
SIRA 02ATEX1391X**



**1. Installation Requirements**

- Ambient Temperature: -20 to 60°C
- Process Temperature: -20 to 60°C  
Other temperature limits are possible with different diaphragm materials
- Refer to appropriate datasheet for materials of construction and technical information.
- These controls are precision instruments and should never be left with internal components exposed. During installation insure that covers are in place and conduit openings are closed except when actually working on the control.
- To minimize the risk of injury, the control must be installed according to the required safety and electrical codes.
- To attain the degree of protection listed on the switch it may be necessary to add required conduit fittings.
- The switch must be protected from moisture, shock and/or extreme vibration.
- Mounting position: Switch can be mounted in any position. It is recommended that unit be set in intended operating position.

**2. Cautions**

- Always install the cover after wiring the switch and before power is supplied.
- Before removing the cover in hazardous areas be sure there is no explosive atmosphere present and the power supply is turned off.
- For ATEX approved switches all safety locking devices and electrical earthing must be installed or connected before operating.
- Never carry a temperature switch by holding only the stem, bulb or capillary.
- Do not push any foreign objects (ex. Screwdrivers) against the diaphragm.
- Do not exceed ranges, current and/or voltage limits.

**3. Mounting**

- Three holes external to the enclosure for surface mounting. Location of these holes is shown in the general dimension drawing.
- Units may also be mounted directly on the pressure line using the pressure connection. When tightening control to pressure line, always use the wrench flats or hex on the lower housing.

**4. Electrical Connections**

- Before operating the switch all conduit entries and/or junction boxes need to be closed according to the required safety and electrical codes.
  - a) Standard product has two 3/4 NPT conduit holes with one permanent plug. 3/4 NPT conduit holes can be modified or reduced with ATEX approved adapters.
  - b) Available ATEX approved cable glands can be used.
- It is recommended that Teflon tape or other sealant be used on conduit, bushing, gland or plug threads to ensure integrity of the enclosure.

**5. Condition for Safe Use**

- Prior to use, the equipment shall be subjected to a pressure test, which shall be based on the process pressure of the associated system. If available, the test shall be conducted in accordance with the requirements of an applicable industry

standard. The pressure shall be applied from the system side of the diaphragm. It must be proven that there is no leakage of the test medium into the flameproof enclosure and that the flameproof enclosure does not become pressurised above ambient atmospheric pressure

**6. Cleaning**

- Never use aggressive solvents.
- Do not use high-pressure water to clean the switch.

**7. Maintenance/Troubleshooting**

- All ASHCROFT switches require little or no maintenance.
- Be sure that the case is closed at all times.
- When the switch is exposed to process media that may harden and/or build up in the pressure port, the switch should be removed and cleaned as needed.
- If the switch does not function, only trained and skilled personnel should check on the wiring, power supply and/or mounting.
- If the problem cannot be solved, please contact either Ashcroft, or our distributors.

**8. Electrical Connections**

- Only trained and skilled personnel are allowed to install the wires to the electrical terminals of the switch.
- Cable couplers, glands and conduit connectors must have the correct electrical approvals.

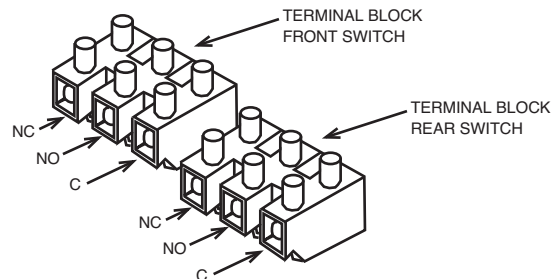

**TABLE 1: MICRO SWITCH ELECTRICAL RATINGS**

MICRO SWITCH CODE				ELECTRICAL RATING	
Single	Dual	Single	Dual	Vac	Vdc
K	KK	20	61	15A, 250V	0.4A, 120V
W	WW	21	65	5A, 250V	
P	PP	22	67	5A, 250V	2.5A, 28V
C	N/A	23	N/A	22A, 250V	
G	GG	24	64	15A, 480V	0.25A, 250V
S	N/A	25	N/A	10A, 250V	10A, 250V
F	FF	26	62	15A, 250V	0.4A, 120V
Y	YY	27	63	15A, 250V	
U	UU	28	N/A	15A, 250V	
E	EE	29	N/A	15A, 250V	
M	MM	31	70	1A, 250V	50mA, 60V
J	JJ	32	68	11A, 250V	5A, 30V
L	LL	42	71	1A, 125V	
N/A	N/A	50	N/A	15A, 250V	
H	HH	35	N/A	10A, 250V	0.3A, 250V

**Installation and Maintenance Instructions for  
B700 ASHCROFT® Snap Action Switches  
ATEX Directive 94/9/EC EEx d IIC T6;  
SIRA 02ATEX1391X**



- Always follow safety and electrical regulations when connecting these devices.
- The system ground of the device is marked with a green colored screw and/or by the ground symbol.
- ATEX approved switches have an external ground screw that must be connected.
- Micro switch terminals and wire color codes:

NO	(Normally Open)	Blue
NC	(Normally Closed)	Red
C	(Common)	White
- SPDT – Wire directly to the switch according to circuit requirements.
- 2 SPDT – Wire to front switch terminal block (left) and rear switch terminal block (right) as marked. Strip insulation  $\frac{5}{16}$ " , insert in proper terminal connector and tighten clamping screw to secure.

### 9. Adjustment of Setpoint

*Note – As indicated below, adjustment of setpoint is made by use of  $\frac{7}{8}$ " nut. Precision switch element mounting screws and bracket adjusting screw are factory sealed and should not be tampered with.*

**B700 Series** – A single setpoint adjustment nut ( $\frac{7}{8}$ " ) is located centrally at the bottom on the inside of the enclosure.

For accurate setpoint calibration, mount the switch on a calibration stand, a pump or catalog No. 1305 deadweight gauge tester. A suitable reference standard such as an ASHCROFT Duragauge or Test Gauge is necessary to observe convenient changes in pressure.

As received, the pressure switch will normally be set to approximately 90% of the indicated range. Pressurize the system to required setpoint and turn the adjustment nut until switch changes mode. Direction of turning is indicated on a label affixed to the inside of the control enclosure. When setpoint has been achieved raise and lower pressure to insure that setpoint is correct.

After installation of the control replace cover to insure electrical safety and to protect internal parts from the environment.

*Note – Since vacuum models are already above setpoint at atmosphere, the Normally Open (NO) circuit will be closed as received.*

**D700 Series** – A single setpoint adjustment nut ( $\frac{7}{8}$ " ) is located centrally at the bottom on the inside of the enclosure.

The direction of turning is indicated on a label affixed to the inside of the control enclosure.

A typical calibration procedure would be as follows:

Static Working Pressure	- 600 psig
Adjustable Differential Range	- 5/200 psid
Differential Setpoint	- 150 psi above static working pressure.

Simultaneously raise the high and low side pressure to 600 psig. Maintain the low side pressure at 600 psig. Raise the high side pressure to 750 psig to obtain 150 psi differential.

Turn the adjustment nut until the switch changes mode at 150 psi differential. When the setpoint has been achieved, raise and lower the high side pressure to ensure that the differential setpoint is correct.

**D700 Series (low range differential)** – A single setpoint adjustment nut ( $\frac{7}{8}$ " ) is located centrally at the bottom on the inside of the enclosure.

The direction of turning is indicated on a label affixed to the inside of the control enclosure. XG5 controls have a setpoint indication scale adjacent to the adjustment nut. To adjust the control, align the top of the adjustment nut hex with the indicator line on the scale. Do not force adjustment or attempt to exceed the maximum setting shown on the scale or nameplate.

For accurate setpoint calibration or for controls without a scale mount the control on a calibration stand so that the HIGH and LOW pressures expected under operating conditions may be obtained. Suitable reference standards are necessary for each pressure.

*Note – Due to the sensitivity of these controls it is imperative that the LOW pressure side volume be large to prevent a setpoint shift between calibration and field installation. If this is not possible, an approximate setpoint under operating conditions can be obtained by setting the operating point with the low side open to atmosphere. A final setpoint adjustment can be made after installation.*

Apply LOW pressure. Then apply HIGH pressure to the required setpoint and turn the adjustment nut until the switch operates. When the setpoint has been achieved, raise and lower HIGH pressure to ensure that the differential pressure between the HIGH and LOW pressures is correct.

After installation of the control, replace the cover to ensure electrical safety and to protect the internal parts from the environment.

**T700 Series** – A single setpoint adjustment nut ( $\frac{7}{8}$ " ) is located centrally at the bottom on the inside of the enclosure.

The bulb of the control should be immersed in a bath at the desired setpoint temperature. Optimum performance will be obtained if the bulb is fully immersed. Allow five minutes for initial stabilization.

As received, the temperature switch will normally be set to approximately 90% of the indicated range. After stabilization, turn the adjustment nut until switch changes mode. Direction of turning is indicated on a label affixed to the inside of the control enclosure. When setpoint has been achieved raise and lower temperature to insure that the setpoint is correct.

After installation of the control replace cover to insure electrical safety and to protect internal parts from the environment.

**B750, D750 and T750 Variable Deadband Switches** – Deadband is varied by rotating the wheel on the precision switch. When viewed from the front of the enclosure, rotation to the left increases deadband – rotation to the right decreases deadband. Letters on the wheel may be used as a reference. Deadbands obtainable will vary from 0.5% to 9% of pressure or temperature range depending on range segment and type of diaphragm.

**Adjustment of Setpoint** – As received, the switch will normally be set to approximately 90% of range. Rotate the wheel on the MICRO SWITCH all the way to the right; this will provide smallest deadband. Pressurize, or increase bath temperature, to the required setpoint and turn the adjustment nut until the switch changes mode. Lower the pressure to reset the switch. Rotate the wheel on the MICRO SWITCH until the desired deadband is obtained. The upper setpoint will be changing upward with this adjustment. Lower the pressure to reset the switch. Then increase the pressure to the desired setpoint and turn the adjusting nut until the switch changes mode. Lower the pressure and check resetpoint and deadband.

**Installation and Maintenance Instructions for  
B700 ASHCROFT® Snap Action Switches  
ATEX Directive 94/9/EC EEx d IIC T6;  
SIRA 02ATEX1391X**



**Pressure switch – psi ranges**

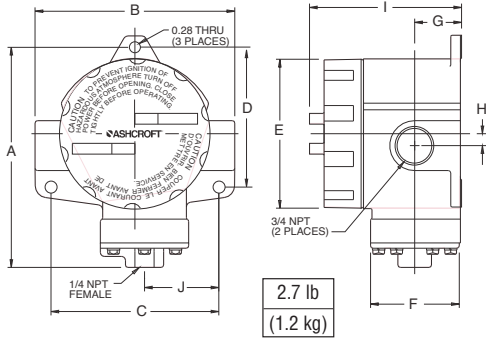

A	B	C	D	E	F	G	H	I	J
5/8	5/8	4 3/8	3 3/8	3 3/8	2 5/16	1 7/32	5/16	3 31/32	1 15/16
(146)	(133)	(111)	(92)	(98)	(59)	(31)	(8)	(101)	(49)

**Differential pressure switch –  
psi differential ranges**

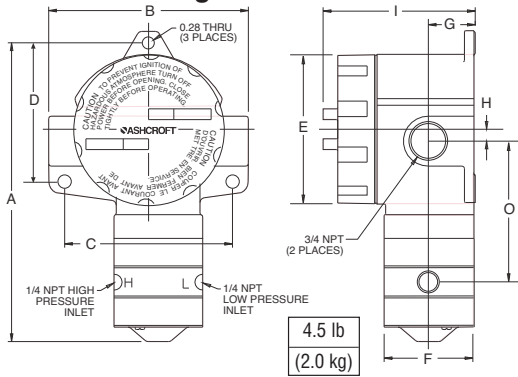

A	B	C	D	E	F	G	H	I	O
7 25/32	5 7/32	4 3/8	3 3/8	3 3/8	2 5/16	1 7/32	5/16	3 31/32	3 11/16
(198)	(133)	(111)	(92)	(98)	(59)	(31)	(8)	(101)	(94)

**Temperature switch – direct mount**

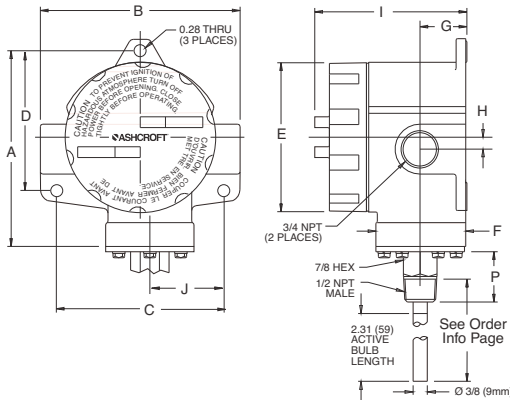

A	B	C	D	E	F	G	H	I	J	P
5 3/32	5 7/32	4 3/8	3 3/8	3 3/8	2 5/16	1 7/32	5/16	3 31/32	1 15/16	1 5/16
(129)	(133)	(111)	(92)	(99)	(59)	(31)	(8)	(101)	(49)	(33)

**Pressure switch –  
inches of water ranges**

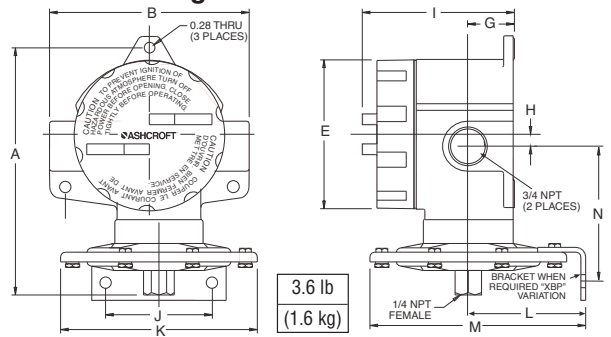

A	B	E	G	H	I	J	K	L	M	N
6 7/16	5 7/32	3 3/8	1 7/32	5/16	3 31/32	2 25/32	5 1/8	3 1/16	5 11/16	3 1/2
(164)	(133)	(98)	(31)	(8)	(101)	(71)	(130)	(78)	(145)	(89)

**Differential pressure switch –  
inches of water ranges**

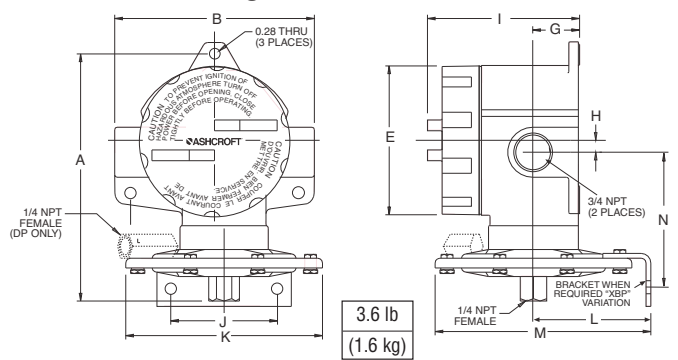

A	B	E	G	H	I	J	K	L	M	N
6 7/16	5 7/32	3 3/8	1 7/32	5/16	3 31/32	2 25/32	5 1/8	3 1/16	5 11/16	3 1/2
(164)	(133)	(98)	(31)	(8)	(101)	(71)	(130)	(78)	(145)	(89)

**Temperature switch – remote mount**

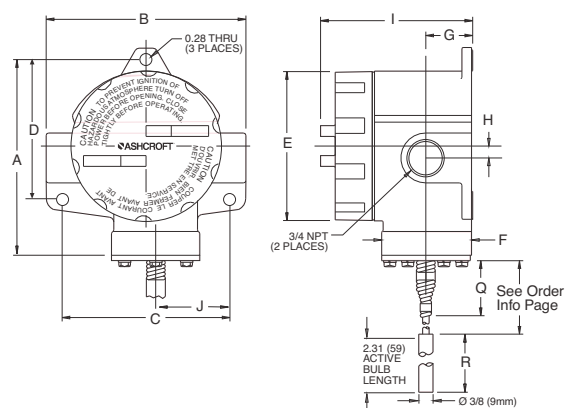

A	B	C	D	E	F	G	H	I	J	Q	R
5 3/32	5 7/32	4 3/8	3 3/8	3 3/8	2 5/16	1 7/32	5/16	3 31/32	1 15/16	3	3
(129)	(133)	(111)	(92)	(99)	(59)	(31)	(8)	(101)	(49)	(76)	(76)

**Installation and Maintenance Instructions for  
B700 ASHCROFT® Snap Action Switches  
ATEX Directive 94/9/EC EEx d IIC T6;  
SIRA 02ATEX1391X**

