

## BAL SEAL® SEALS IN REGULATOR VALVES

Regulator valves control the flow of gases and liquids, such as air, helium, nitrogen, hydraulic fluids, chemicals, and corrosive media, from high pressure to low pressure. A regulator valve must provide reliable service over a long period of time under various pressure and temperature conditions.

A regulator has a spring-loaded poppet, a spring-loaded piston and a knob, which controls the regulator's spring force. The downstream pressure actuates the piston and allows fluid to pass through the regulator at a higher or lower flow rate. Flow continues until both the downstream pressure and the regulator's primary spring force are in balance.

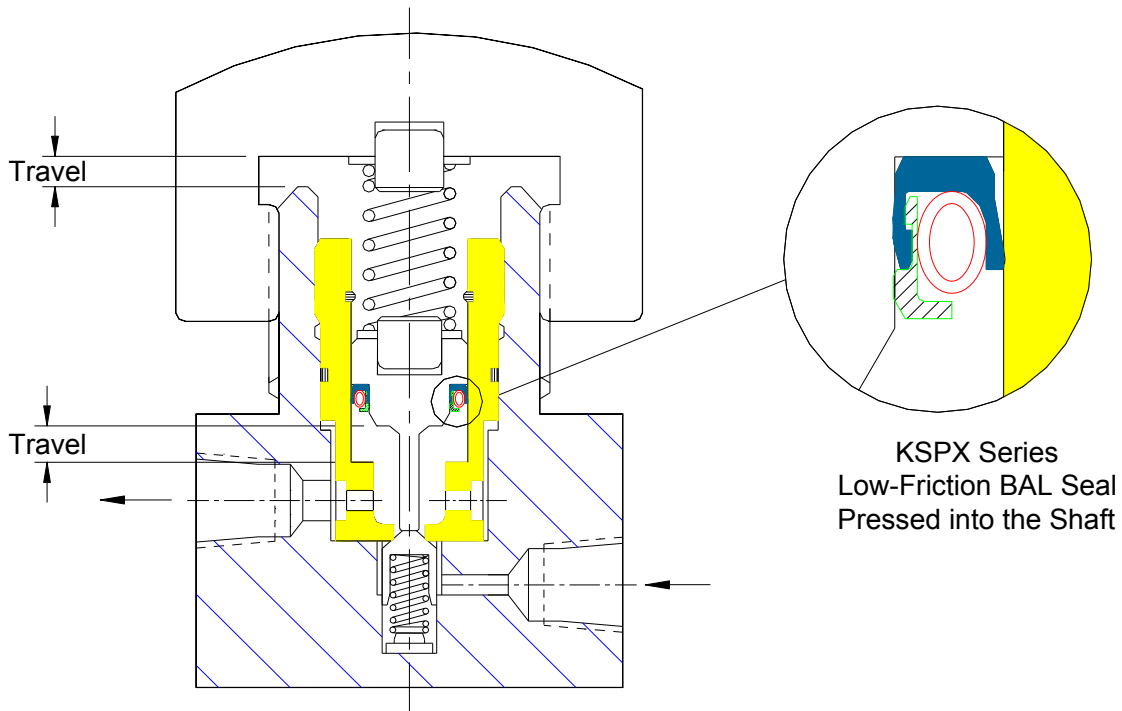

### Operating Parameters

Pressure: 0 to 1,000 psi (0 to 70 kg/cm<sup>2</sup>)  
Temperature: - 65°F to 160°F (- 54°C to 71°C)  
Media: Air, inert gases, corrosive fluids, hydraulic fluids and water

### Seal Selection:

Selected for its low friction, chemical compatibility, and ease of assembly, a KSPX series Bal Seal® seal is made from a PTFE-based material and has the ability to operate over long periods under various pressure and temperature conditions. The Bal Seal KSPX series seal is loaded with the unique, patented, canted-coil spring, which provides low friction and improved sealing ability.

When used in a seal, the force of the canted-coil spring remains relatively constant within its working deflection. This feature maintains low friction while compensating for seal wear, eccentricities, side loading, machining irregularities, and other variables. The regulator effectively maintains the selected pressure within the operating requirements.

For more information and technical assistance, consult the Technical Sales Department.