

BAL SEAL® SEALS IN HOT MELT ADHESIVE DISPENSING VALVES TEMPERATURES TO 400°F (204°C)

Many industries use valves to dispense and control the flow of single part adhesives and hot melt fluids. Typically, these applications are extremely harsh on sealing components because of the high temperatures, abrasive fluids and high velocities.

Bal Seal Engineering, Inc. pioneered a line of sealing solutions tailored for such hot melt valves. These field-proven sealing solutions provide millions of cycles and reliable sealing. Made from formulated and blended PTFE or other engineered polymer compounds to optimize performance, these seals are mounted with the Bal Seal patented metal locking ring that is pressed into the housing to maintain secure mounting despite repeated thermal cycling.

In addition, the seal has a Bal Seal canted-coil spring energizer to maintain a near-constant sealing contact force against the plunger throughout the seal life. Bal Seal® seals also have proven performance in a multitude of other valve types, including gate valves, ball valves and needle valves.

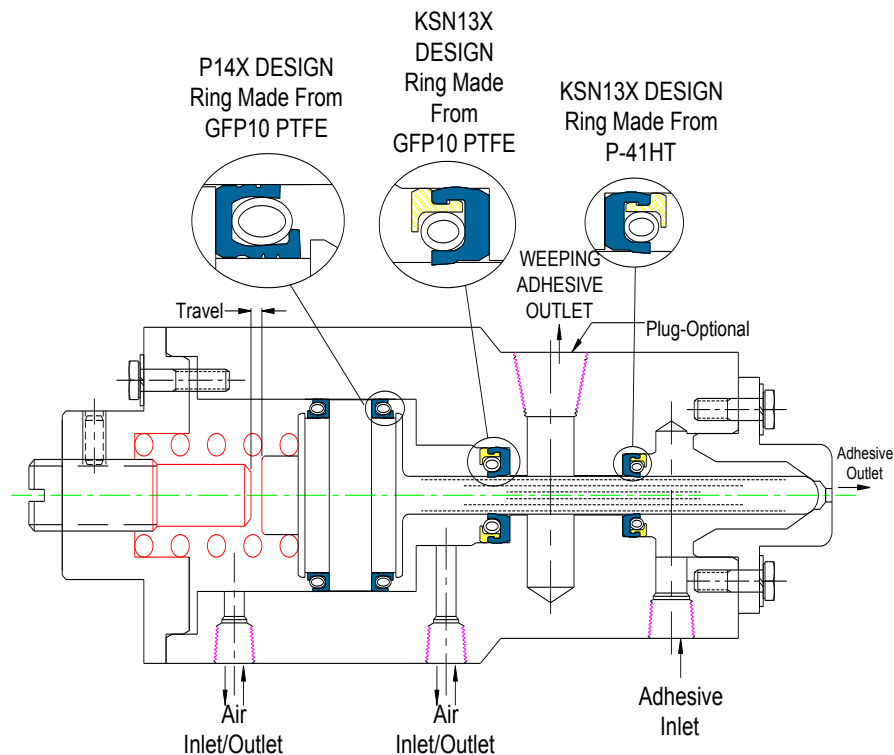

Operating Parameters

Pressure:	To 1,000 psi (70 kg/cm ²)
Media:	Hot Melt Packaging
Temperature:	To 400°F (204°C)
Speed:	4 feet per minute (1.22 meters per minute) @ 1,000 cycles per minute
Additional:	Low-frictional forces, variable pressure and temperature endurance

Features:

- Bal Seal K Series with metal locking rings pressed into the housing reduce diametrical seal shrinkage and provide reliable sealing under constant thermal cycling.
- Bal Seal Canted-coil springs energize the polymer seal ring improving sealing.
- The unique seal contact geometry results in excellent sealing performance.
- The patented, Canted-coil spring energizer provides near-constant force for optimal performance and long seal life; they are available in many different materials and loads to accommodate good sealing and low-frictional drag at various temperatures.
- Bal Seal Engineering provides filled PTFE seal materials with excellent wear resistance and chemical compatibility as well as other high-temperature engineered polymer compounds to meet long-term application needs.

For more information and technical assistance, contact the Technical Sales Department.

PATENTS: The items described in this page include products that are the subject of issued United States and foreign patents or products where patents are pending, including the following: Patents 6,641,141 B2; 7,210,398 B2; 6,161,838; 5,992,856; 5,134,244
U.S. Address 19650 Pauling Foothill Ranch, CA 92610-2610 • Phone: (949) 460-2100 • Fax: (949) 460-2300

BV Address: Jollemanhof 16, • 1019 GW Amsterdam • The Netherlands • Phone: 31 20 638 65 23 • Fax: 31 20 625 60 18

Rev.B 10-19-07(11-293)

Bal Seal Engineering, Inc. is certified to ISO 9001 | www.balseal.com