

Ferraris Acceleration Sensor - Principle and Field of Application in Servo Drives

Bernhard Hiller

Hübner Elektromaschinen AG, Berlin, Germany

Tel.: +49/30/69003-101, email: hiller@huebner-berlin.de

Abstract: The Ferraris principle for measurement of the relative acceleration has been known for more than 100 years. In academic works the potential of this sensor principle has been demonstrated again and again /1, 2/. But only commercial production which has been started some years ago opened up possibilities for the sensor principle in industrial applications. The simple and robust design, combined with non-contact object measurement, predetermines the sensor for application in rotary and linear motion axis. Ferraris sensors can be used either for analysis of motion behaviour or for improved control of servo drives of all kind. This lecture describes the principle, the design and the profitable application fields of the relative acceleration sensor.

Motivation

Continuous request for increasing productivity together with higher precision of N/C machines, such as machine tools, printing machines, but also robots and a variety of machines in the field of automation engineering results in increasingly high requirements for the servo or main drives used therein. High dynamics, good synchronism and best possible disturbance reaction of controlled drives are basic conditions for increase in productivity and quality of the entire plant. This in turn requires that the state variables position, velocity and acceleration must be acquired quickly and precisely so that, despite of disturbance and machining forces effecting the drive, the desired motion can be performed exactly, dynamically and in synchronisation with other drives.

Requirements for the quality of state variable acquisition are especially high for direct drives, as the stiffness has to be provided by the control device exclusively. To make full use of the potential of direct drives which origins from omission of deficiencies caused by gears and spindle such as elasticity or backlash, high resolution and dynamics of the state variables have to be demanded.

If moreover at servo drives, especially at direct drives, concepts of acceleration feedback, state control, cascaded acceleration control or active damping for further improvement of control per-

formance shall be applied - which have been known since long, but applied only seldom - direct acquisition of the relative acceleration is required in addition to the position.

Present Acquisition of State Variables

Today cascade control is mainly applied in digital servo drives. Measurement is limited to the current and the position only. Position acquisition is mainly based on incremental or absolute rotary or linear encoders. High resolutions can be achieved by sine encoders as their analogue signals can be multiple partitioned compared to the signal period. Optical systems allow signal periods which are typically 20 µm and permit resolutions of 20 nm and below. In applications with lower requirements concerning positioning accuracy magnetic, inductive and partly capacitive systems are applied. In these systems the signal periods are within the millimeter range and permit resolutions of 1 µm and below. Better robustness in comparison to optical systems, higher assembly tolerances and lower costs, are arguments for these position measuring devices. However, significant cuts have to be made in the achievable control performance due to lower resolution and precision. For all systems it should be taken into consideration that precision within one signal period is considerably worse than the resolutions as the sampled signals and their processing are never optimal /2/.

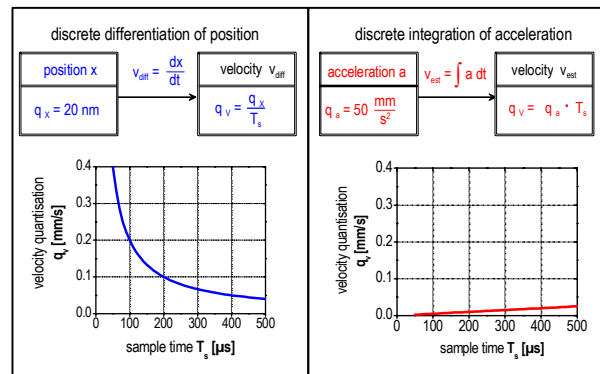

Figure 1: Velocity acquisition and quantization

Velocity is mostly determined by discrete differentiation of the position. Thus quantization and

above all other errors of the position are turning up in an amplified way. Velocity quantization q_v is proportional to position quantization q_x and reversely proportional to the sampling time T_s (Figure 1 left side). Modern servo controller work at sampling times of $62,5 \mu\text{s}$ and below. The velocity quantization caused by this leads to serious problems, even at high position resolution. A compromise between quantization noise (and the related stimulation of vibrations, acoustic noise development and temperature rise in the motor) and the obtainable stiffness and dynamics of the drive has to be found in any case. Application of digital filters or observers for velocity smoothening deteriorates the disturbance behaviour of the drive as disturbance forces can be recognized with a delay only. As with the application of band elimination filters for suppression of weakly damped, higher frequencies, this requires a considerable parameterization effort. Additional problems may be caused by position depending and gradually changing resonance frequencies and plant parameters [2]. Using more precise measurement systems with smaller signal periods, which leads to a higher position resolution and thus decrease of velocity quantization, often is not reasonable due to cost and robustness factors. Moreover, a possible limitation of the maximum speed must be taken into consideration.

Ferraris Acceleration Sensor

Significant improvement of the control behaviour of servo drives allows the application of acceleration sensors. Measurement of acceleration provides the state variable representing the direct and instantaneous reaction of the mass to be moved to the forces acting upon. Acceleration is therefore suited as feedback signal (e.g. for system damping) or for construction of cascade acceleration control which allows significant increase in disturbance reaction and dynamics. Integration further leads to excellent, low quantized velocity (Figure 1 right side). The position does not necessarily need high resolution allowing the use of robust, low-cost position measuring systems.

The principle of the Ferraris sensor has been created by the Italian Galileo Ferraris more than 100 years ago and is to be explained by means of Figure 2 [2]. When turning the conductive eddy current disc (rotor) of non-magnetic material, in the area of the stationary excitation magnetic fields eddy currents are created within the rotor with secondary, velocity-proportional magnetic fields as a consequence. They are detected

by the pick-up coils. The voltage induced in the pick-up coils is proportional to the change in these magnetic fields and thus to the angular acceleration.

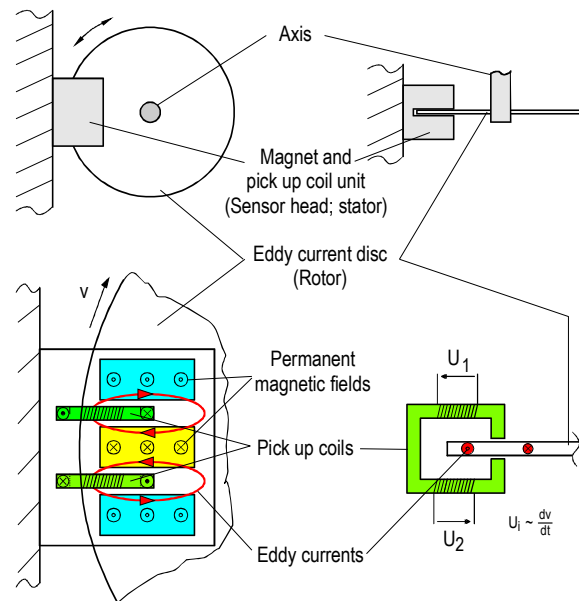

Figure 2: Principle of the Ferraris sensor [2]

The Ferraris sensor is characterized by the following features [1, 2].

- The Ferraris sensor measures only the *relative* acceleration between eddy current material and sensor head. Thus the sensor is preferredly used in the drive technology of machines and plants where not absolute, but only relative movements are of importance. Acceleration sensors based on the spring-mass principle are measuring the absolute acceleration and thus partly cause problems.
- It is not based on an oscillatory system. Thus the Ferraris sensor is very robust and resistant to highest shock accelerations.
- The Ferraris sensor is an active, non-contact sensor. During occurrence of acceleration a small, low-noise and offset-free voltage is induced in the measuring coils directly.
- The low-noise signals allow scaling of the measuring range in wide limits only via the gain of the back-end sensor amplifier.
- Large installation tolerances permit stiff attachment without coupling.
- There is no low-end frequency limit like with absolute piezoelectric sensors. The bandwidth can be varied by the type of eddy current material used and the design of the excitation- and pick-up units.
- In case of angular acceleration measurement the measuring signal is taken at the stator;

transmitters for the measured values are not required. This reduces the costs and increases reliability compared to other principles.

- As the sensor works with eddy currents, aspects of heating and retroactivity to the exciting magnetic field have to be taken into consideration, because they reduce the transfer ratio.

Types

During further development of Ferraris sensors, stress was put on the requirements for practical use. Beside the basic types described herein, there are further types which have been optimized either concerning sensitivity, bandwidth or maximum speed range.

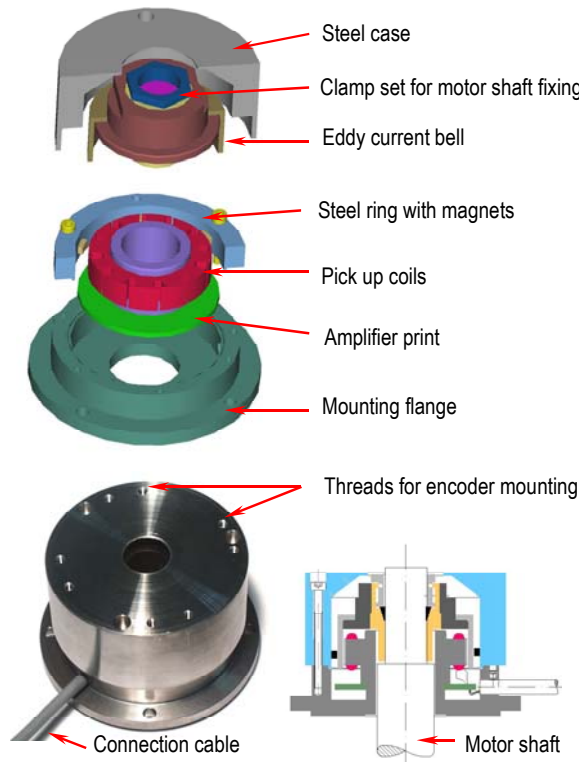

Figure 3: Rotary acceleration sensor ACC 70

Figure 3 shows the ACC 70 type. The design of the eddy current material as an aluminium- or copper bell with hollow shaft, which is fixed to the motor shaft by means of the clamp set, allows an axial offset of up to 2 mm on the one hand and on the other hand firm fixing without coupling of the sensor directly to the motor flange. Often a hollow shaft encoder or resolver for position measuring is assembled to the motor shaft which is pushing through the acceleration sensor. The housing of this may be fixed to the ACC 70 by means of a stator coupling. As six sensor coils have been distributed internally around the entire circumference, this construction is especially

insensitive to reeling and eccentric run of the eddy current bell and electromagnetic interference fields.

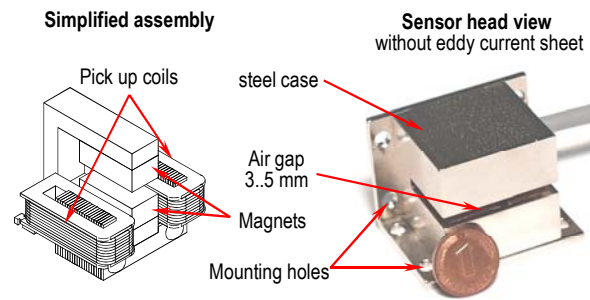

Figure 4: Linear / rotary acceleration sensor ACC 93

Type ACC 93 (Figure 4) is a compact linear acceleration sensor which is also used in roundtables, robots and torque motors. Though the construction style is very compact, the patented arrangement of the pick-up unit allows high sensitivity and good disturbance suppression. The eddy current sheet or disc (thickness: 0.3 mm to 2.5 mm) is encompassed by the slotted sensor head (width of air gap: 3 to 5 mm) allowing large installation tolerances.

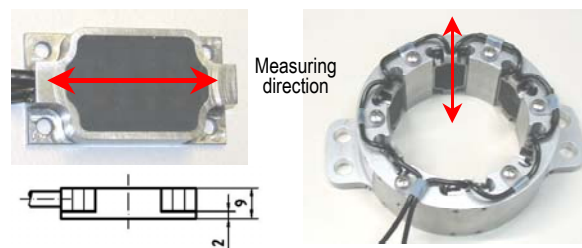

Figure 5: Single-side acceleration sensor ACC 22

The latest development is the ACC 22 type as shown in Figure 5 left side which is scanning the eddy current sheet or just a non-magnetic body on one side only. This requires a considerably smaller space for installation. Due to a new patented magnet and coil arrangement the sensor is only 9 mm in high and provides a bandwidth up to 5 kHz. The transfer ratio, however, is lower than in ACC 93. Moreover it has to be considered that distance variations between sensor head and eddy current material influence the sensor signal. Figure 5 right side shows 6 sensor heads of the ACC 22 type which have been installed in an assembly ring. They will scan the titanium piston of a highly dynamic hydraulic drive. As known, the acceleration feedback in controlled hydraulic axis permits considerable increase in performance.

Characteristics Data of Ferraris Sensors

The *transfer ratio* defines the voltage per acceleration ($V/\text{rad s}^{-2}$ or V/g) supplied by Ferraris sensors without amplification. It depends on the exciting magnetic field, the conductivity and thickness of the eddy current material, the design of the pick-up units and the geometry. Due to retroactivity of the magnetic field generated by the eddy currents to the exciting magnetic field, the transfer ratio is reduced at higher speeds. This effect is also made use of at high speed to avoid extreme heating caused by the eddy currents and *braking effects* /3/.

Disturbance *sensitivity towards external alternating magnetic* fields is considerably reduced by clever positioning and circuitry of several pick-up coils. In addition magnetic shielding housings are used. Static magnetic fields do not have any effect on the measuring signal.

Transfer ratio depends on the frequency and at good approximation shows *first order low-pass behaviour*. The time constant is proportional to the conductivity and thickness of the eddy current material and depends on the enclosing area of the eddy currents and the pick-up unit construction. Thus a very small sensor is of advantage. It is obvious that an application-specific compromise between maximum measuring frequency and transfer ratio has to be found. By connection of several „small“ pick-up units in tandem, a high bandwidth can be combined with a large transfer ratio and good disturbance suppression. The *bandwidth* of actual sensors varies between 300 Hz and 5 kHz. A *signal-to-noise ratio* of > 70 dB can be achieved.

Without special measures, the transfer ratio of Ferraris sensors shows a *negative temperature coefficient*. The temperature coefficient corresponds to that of the eddy current material (aluminium, copper, bronze, brass) and the permanent magnets. Due to this reason electronic temperature compensation has to be provided in case of high requirements for temperature stability of the transfer ratio. Application of constantan or manganin as eddy current material may lead to a temperature coefficient near zero, but due to lower conductivity the transfer ratio is then considerably lower. Likewise cost aspect should be taken into account.

Sensor Amplifier

The sensor amplifier may either be integrated into the sensor housing or positioned externally. As it has to convert voltages of partly only μV to a usable output level, high-quality differential amplifiers with low noise and offset level are

used. Thus sensitivity adjustment (*normalisation factor*) of the Ferraris sensor can be achieved by simply changing the gain of the sensor amplifier. The gain range is between 2 and 20000. At present two measuring amplifiers are used:

- unipolar supply with 4.5 Volt to 30 Volt; differential output with an amplitude of $1 V_{SS}$ (maximum $4 V_{SS}$); digital programming of gain and offset, via RS 485 or USB interface. In near future complex filters, temperature and speed compensation of the transfer ratio will be implemented, too,
- bipolar supply with ± 5 Volt to ± 18 Volt; differential output with a maximum amplitude of $20 V_{SS}$; gain adjustment via potentiometer and jumper.
- future versions will provide a BiSS-interface /4/

Field of Application of Ferraris Sensors

acceleration measurement (without control involvement)	acceleration measurement to improve servo-control
➤ test-bench	➤ improved velocity acquisition
➤ system analysis	➤ acceleration feedback / active damping
➤ measuring stations	➤ acceleration control
➤ vibration supervision	➤ state control
➤ force / torque and friction reconstruction	

Figure 6: Possible application of Ferraris sensors

Due to space reasons only few applications listed in Figure 6 will be mentioned here.

Figure 7 shows a linear axis with timing belt being equipped with a single-side scanning Ferraris sensor for system analysis. Eddy current material is a simple copper band which has been gummed to the aluminium profile. The sensor head has been screwd to the carriage. At a given position ramp (Set values: Position x : 400 mm; Velocity v : 1 m/s; Acceleration a : 10 m/s^2) the amplified, digitized signal of the Ferraris sensor is sampled (sampling frequency: 10 kHz). As the normalisation factor is not known first, it has to be determined by double integration of the sampled acceleration signal and subsequent comparison with the (known) final position value, a process which can be done automatically. The superimposed vibration of the slide at approx. 250 Hz caused by the elasticity of the timing belt can be seen in a time-zoomed view of acceleration (Figure 8). The acceleration values are partly double as high as the set value for acceleration. Feedback of acceleration may dampen the vibration and thus considerably improve motion behaviour.

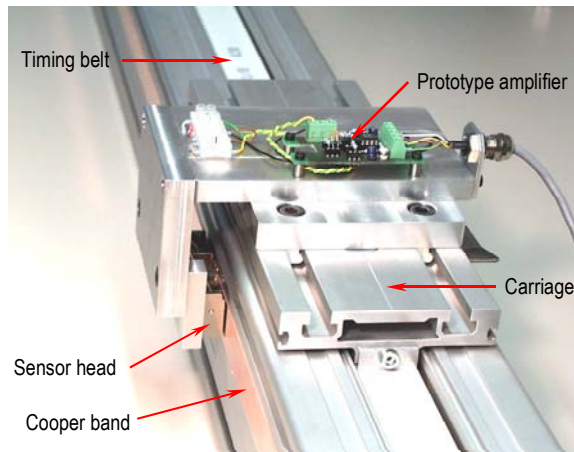

Figure 7: Linear axis with single-side Ferraris sensor

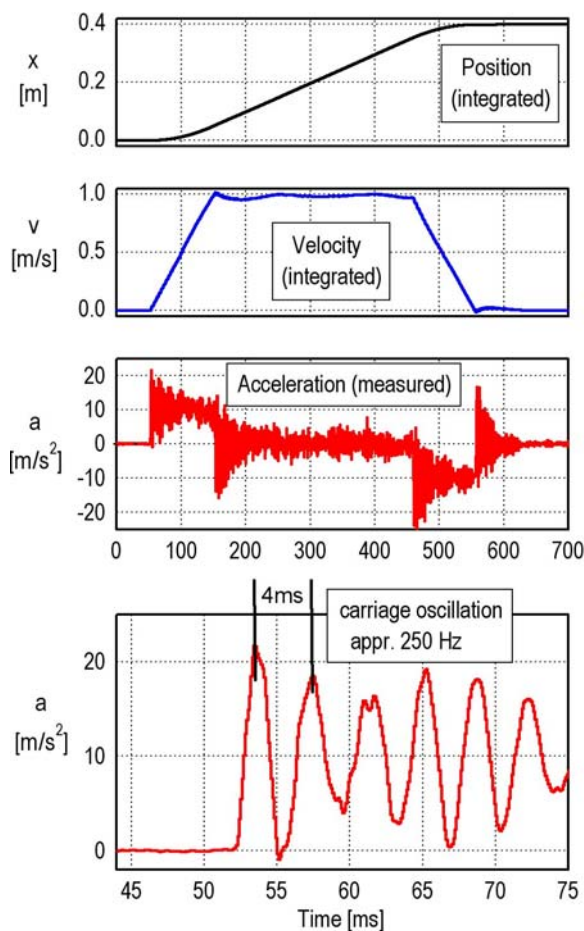

Figure 8: Acceleration of timing belt linear axis

The following example shows the improvement of the control behaviour when combining the Ferraris sensor with a low cost, low resolution encoder. For position measurement in a small, iron-free and highly dynamic linear direct drive (Figure 9) an optical non-capsulated linear en-

coder with a signal period of 20 μm and a robust magnetic system with a pole distance of 1 mm is used. After interpolation the position is available with a resolution of approx. 20 nm respectively 1 μm . It would be easy to supply even higher resolution, but this is only partially reasonable, as then the errors of the respective position measuring device are shown in higher resolution only.

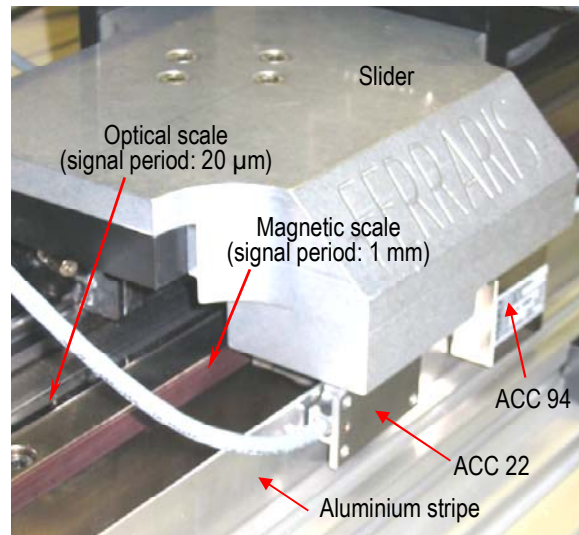

Figure 9: Linear direct drive with different linear encoders and acceleration sensors

For measurement of the acceleration a_{meas} a Ferraris sensor Type ACC 94 (similar to ACC 93 but with higher bandwidth) is used which is fixed to the slider. A simple aluminium sheet of 1 mm thickness, which is connected to the machine bed is applied as eddy current material. The ACC 94 in combination with the amplifier's gain and a 12bit AD-converter in the drive controller offers a resolution of 0.057 m/s^2 and a large measurement range of $\pm 116 \text{ m/s}^2$ (about $\pm 12 \text{ G}$).

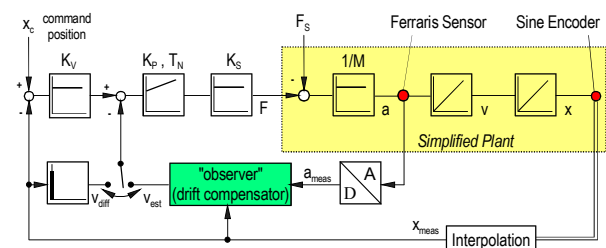

Figure 10: Cascade controller with optional improved velocity acquisition by Ferraris Sensor

For the digital control (sample time: 62.5 μs), the structure shown in Figure 10 is used [2].

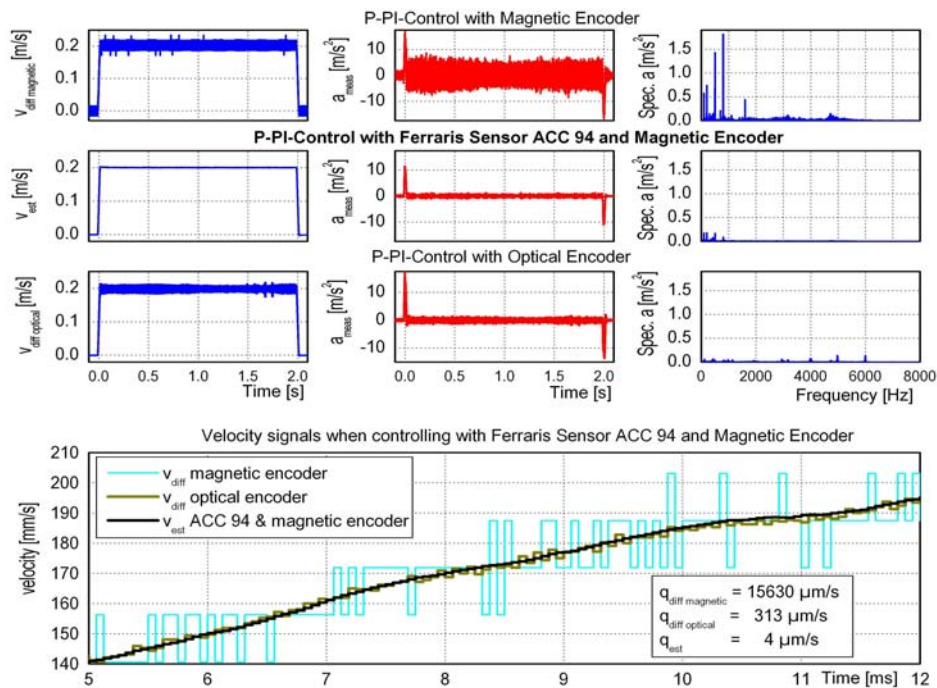

Figure 11: Comparison of velocity and acceleration signals of an high dynamic linear direct drive using different velocity acquisition and high controller gains ($K_V=200$ 1/s; $K_P=400$ 1/s)

This structure differs from the classic cascade controller only in the fact that for the velocity a choice between v_{diff} and v_{est} is possible. The signal v_{est} is determined by an observer structure /5/ and mainly corresponds to the discrete integrated acceleration. The observer avoids low-pass drifting due to small errors of the sampled acceleration. For this a low-pass alignment with the quantized, still faulty, but offset-free position x_{meas} is done and an offset-free acceleration is calculated. High resolution and dynamics of v_{est} , however, are exclusively guaranteed by the acceleration a_{meas} . The observer may also be extended to get a minor quantized position x_{est} . This is especially reasonable if, due to the use of a position with low resolution, quantization causes problems in the position control loop, too. As the Ferraris sensor usually scans the same movement as the encoder, the parameters in the observer structure are independent of the plant parameters (load mass, friction, time constants). The normalisation factor and the offset of a_{meas} can also be determined or readjusted independently by means of adaptive structures /6/. Figure 11 shows speed, acceleration and spectrum of acceleration for the different types of speed measurement. Speed ripple, excitation of mechanical structure vibrations and noise can be reduced by application of a combination of Ferraris sensor and magnetic encoder in the same way as if using the more expensive, sensible, optical encoder.

Summary

The Ferraris sensor allows non-contact, low-noise and dynamic measurement of the relative acceleration of two bodies, and thus offers a wide field of application in system analysis and improvement of servo drive control. The newly developed Ferraris sensors have been adapted to the users' requirements and allow acceleration measurement with high resolution and bandwidth at rotary or linear axis and this with compact design and easy assembly. Latest developments deal with further reduction in size and constructive and signal-electronic combination of Ferraris sensors and incremental or absolute position measuring systems of high or and low resolution.

References

1. Sobota, J.: Drehbeschleunigungsmessung an Antrieben, Dissertation, TH Aachen, 1985.
2. Hiller, B.: „Verfahren zur hochgenauen Erfassung von Zustandsgrößen an Maschinenachsen“, in: Spur, G., Weck, M., Pritschow, G., Technologien für die Hochgeschwindigkeitsbearbeitung, VDI-Verlag, Düsseldorf, 1998.
3. Wilhelmy, L.; Domke, R.: Drehbeschleunigungssensor ermöglicht hochgenaue Drehzahlregelung. Antriebstechnik 38 (1999) Nr. 4, pp.122-125
4. Quasdorf, J; Schulz, J.: Sensorkommunikation mit BiSS, Elektronik 7/2002.
5. Jirowskaja, E.: Entwicklung und Aufbau eines Relativbeschleunigungssensors für Direktantriebe, ISW, Universität Stuttgart, Diplomarbeit, 1996.
6. Kramer, C., Willuweit, G.: Adaptive Beobachterstruktur für Ferraris-Sensoren, Antriebstechnik 41; Nr. 9, 2002.