

FAST HIGH VOLTAGE TRANSISTOR SWITCHES

These MOSFET switches are designed for general high voltage switching applications such as pockels cell drivers, deflection and acceleration grid drivers, piezo drivers, MCP/SEV pulsers and DC/DC converters. The switching modules incorporate all features of the well known HTS switch family: Easy handling, high reliability, low jitter and precise switching. In contrast to conventional high voltage switches like spark gaps, electron tubes, gas discharge tubes and mechanical switches, HTS transistor switches show very stable switching characteristics independent of temperature and age. The mean time between failures (MTBF) is by several orders of magnitude higher than that of the classical HV switches. The switching modules are controlled by an interference-proof driver circuit which provides signal conditioning, auxiliary voltage monitoring, frequency limitation and temperature protection. In case of false operating conditions the switches are immediately turned-off and a fault signal is generated (not available for "pigtail" devices). The switches are turned-on by a positive going signal of 2 to 10 volts amplitude. The on-time may be varied between 100 ns and infinity. A short recovery time of 300 ns allows burst frequencies up to 3.3 MHz. Due to the galvanic isolation of more than 10 kV the switches may simply be operated also in high-side circuits. Three housing options are available to meet individual electrical and constructive requirements. The plastic case is the cost-effective standard package in low frequency, pulsed power applications with a low continuous power dissipation. The standard housing has soldering terminals and "pigtailed" for connection. It is also available as a printed circuit board version with soldering pins at bottom (option 06). To increase the Maximum Power Dissipation $P_{d(max)}$ the plastic modules can additionally be fitted with non-isolated cooling fins (option 04), which improve the $P_d(max)$ value by approximately the factor 5. A metal case for a continuous power dissipation of up to 400 Watt is also available (option 05, cf. data sheet "High Power Metal Case"). For detailed design recommendations please refer to the general instructions.

HTS 31

3000 VDC / 30 Amps

HTS 51

5000 VDC / 30 Amps

HTS 81

8000 VDC / 30 Amps

**High Frequency
Variable On-Time**

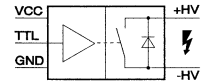

Standard plastic case with pigtail connection

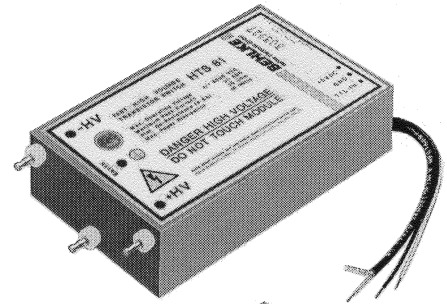

Plastic case for PCB insertion (flat version, option 06-B).

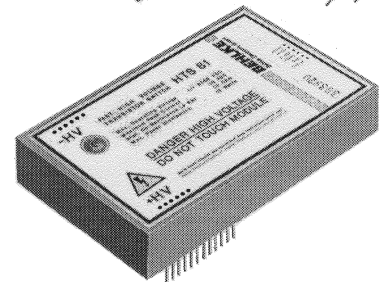

Standard plastic case with copper cooling fins for increased power dissipation (option 04)

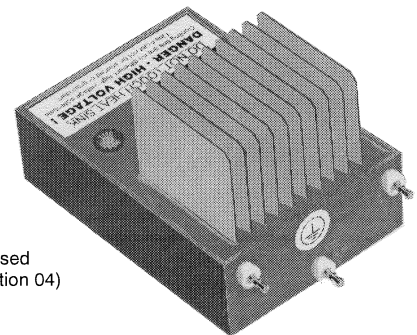

Basic Circuits

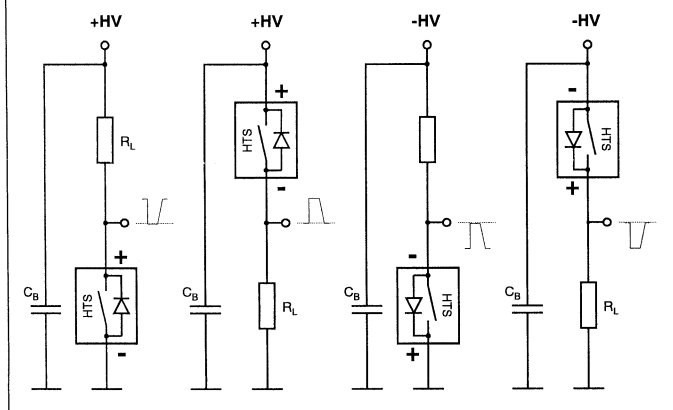

Test Circuit

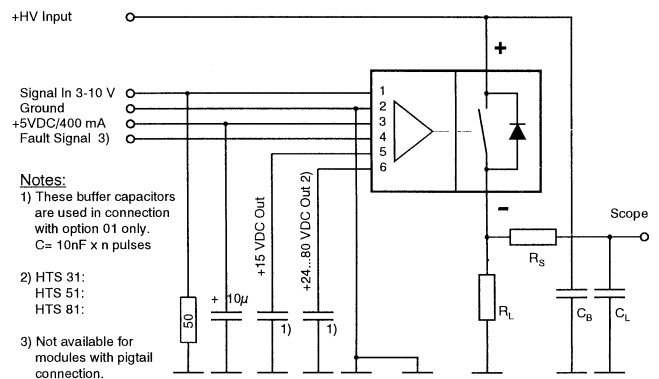

TECHNICAL DATA

Specification	Symbol	Condition / Comment		HTS 31	HTS 51	HTS 81	Unit
Maximum Operating Voltage	$V_{O(max)}$	$I_{off} < 10 \mu ADC$		3000	5000	8000	VDC
Minimum Operating Voltage	$V_{O(min)}$	Increased $t_{r(on)}$ and $t_{r(off)}$ below $0.1 \times V_{O(max)}$		0			VDC
Typical Breakdown Voltage	V_{br}	$I_{off} > 1mADC$, $T_{case} = 70^\circ C$		3600	6000	9600	VDC
Galvanic Isolation	V_I	HV part against control, standard		>10000			VDC
Maximum Peak Current	$I_{P(max)}$	$T_{case} = 25^\circ C$	$t_p < 10 \mu s$, duty cycle $< 1\%$ $t_p < 100 \mu s$, duty cycle $< 1\%$ $t_p < 1 ms$, duty cycle $< 1\%$	30 24 17			ADC
Maximum Continuous Load Current	I_L	$T_{case} = 25^\circ C$ respectively $T_{fin} = 25^\circ C$	Standard plastic case Ditto + option 03 Ditto +cooling fins (opt. 04) Metal case B1 (opt. 05)	0.71 0.87 - -	0.58 0.71 - -	0.45 0.55 1.09 2.83	ADC
Static On-Resistance	R_{stat}	$T_{case} = 25^\circ C$	$0.1 \times I_{P(max)}$ @ $I_{P(max)}$	8 20	12 30	20 50	Ω
Maximum Off-State Current	I_{off}	$0.8 \times V_O$, $T_{case} = 25...70^\circ C$		5			μADC
Turn-On Delay Time	$t_{d(on)}$	@ $I_{P(max)}$		100			ns
Typical Turn-On Rise Time	$t_{r(on)}$	$0.8 \times V_O$, 10-90 %	$0.1 \times I_{P(max)}$ $1.0 \times I_{P(max)}$	6 9			ns
Typical Turn-Off Rise Time	$t_{r(off)}$	$0.8 \times V_O$, $0.1 \times I_{P(max)}$, resistive load, 10-90%		7			ns
Minimum On-Time	$t_{on(min)}$	Limited by driver circuit		100			ns
Maximum On-Time	$t_{on(max)}$	Please note possible $P_{d(max)}$ limitations		∞			
Switch Recovery Time	t_{rc}	t_{rc} = minimum pulse spacing		300			ns
Typical Turn-On Jitter	$t_{j(on)}$	$V_{aux} / V_{tr} = 5.0 VDC$		100			ps
Max. Switching Frequency	$f_{(max)}$	Please note possible $P_{d(max)}$ limitations		100	70	40	kHz
Maximum Burst Frequency	$f_{b(max)}$	Use option 01 for >10 pulses within $<20 \mu s$		3.3			MHz
Maximum Continuous Power Dissipation	$P_{d(max)}$	$T_{case} = 25^\circ C$ respectively $T_{fin} = 25^\circ C$	Standard plastic case Ditto + option 03 Ditto +cooling fins (opt. 04) Metal case B1 (opt. 05)	10 15 - -	10 15 - -	10 15 60 400	Watts
Linear Derating		Above $25^\circ C$	Standard plastic case Ditto + option 03 Ditto + cooling fins (opt. 04) Metal case B1 (opt. 05)	0.22 0.33 - -	0.22 0.33 - -	0.22 0.33 1.33 6.66	W/K
Temperature Range	T_O	Plastic case, plastic case +cooling fins Metal case B1 (option 05)		-40...70 -30...85			$^\circ C$
Natural Capacitance	C_N	Capacitance between switch poles at $V_{O(max)}$		110	75	45	pF
Coupling Capacitance	C_C	HV side against control side		16			pF
Diode Reverse Recovery Time	t_{rrc}	$I_F = 0.1 \times I_{P(max)}$	MOSFET parasitic diode	500			ns
Diode Forward Voltage Drop	V_F	$I_F = 0.1 \times I_{P(max)}$	MOSFET parasitic diode	6	9	15	VDC
Auxiliary Supply Voltage	V_{aux}	Stabilized to $\pm 5\%$		5.0			VDC
Auxiliary Supply Current	I_{aux}	@ f_{max}		400			mADC
Control Signal	V_{tr}	$> 3VDC$ recommended		2-10			VDC
Fault Signal Output		TTL compatible, short circuit proof, L=Fault		H= 4 V, L= 0.5 V			VDC
Dimensions	LxBxH	Standard plastic case Flat plastic case (opt. 06-B) Plastic case + cooling fins (opt. 04) Metal case B1 (opt. 05)		89 x 64 x 27 89 x 64 x 19 89 x 64 x 60 180 x 100 x 53.5			mm ³
Weight		Standard plastic case Flat plastic case (opt. 06-B) Plastic case + cooling fins (opt. 04) Metal case B1 (opt. 05)		250 190 350 2500			g

Ordering Informations

HTS 31	Transistor switch, 3000 VDC, 30 Amps.	Option 04	Cooling fins, non-isolated
HTS 51	Transistor switch, 5000 VDC, 30 Amps.	Option 05	Metal case B1, potential-free (cf. separate data sheet)
HTS 81	Transistor switch, 8000 VDC, 30 Amps.	Option 06	Soldering pins for printed boards, module height 27 mm
Option 01	High frequency burst	Option 06-B	Ditto, module height 19 mm (options 02,03, 04 excluded)
Option 02	Flame retardend casting resin UL94-VO	Option 08	30 kV instead of 10 kV isolation, module size on request
Option 03	Increased thermal conductivity	Option 08-B	80 kV instead of 10 kV isolation, module size on request

All data and specifications subject to change without notice. Custom designed devices on request.