

★ For use with Globespan EL-1510

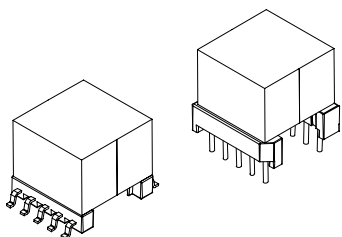

★ Designed to meet IR 235<sup>o</sup>C peak requirement

★ Excellent THD performance

★ Small EP13 Package in SMD and THT Type

Specifications					
Part Number	Application	Turn Ratio (2%)	OCL @ 10 KHz, 0.1 V	Leakage Inductance @ 10 KHz, 0.1 V	Longitudinal Balance (from 20 KHz to 250 KHz)
AT0013	CO	1 : 1.4 (1-5) : (10-6)	474 uH (±5%) (10-6), 7-9 shorted	15 uH Max (10-6), 1-2- 4-5 shorted	-55 dB Min
AT5013					
AT0002	CPE	1:1(1-5):(10-6)	407.5uH (±6%)	10 uH Max	-55 dB Min
AT5002		1:1(1-4):(10-7)			

Specifications continue					
Part Number	THD	DCR (1-5), 2-4 shorted	Isolation Voltage (Vrms)	Insertion Loss @ 300 KHz	Package
AT0013	-80 dB MIN @100 KHz, 15Vac	2.1 Ω Max	1500	0.5 dB Max	SMD
AT5013					THT
AT0002	-85 dB MIN @100 KHz, 5.3Vrms	1.0 Ω Max	1500	0.5 dB Max	SMD
AT5002					THT

**Schematic**

AT0013/AT5013/AT0002

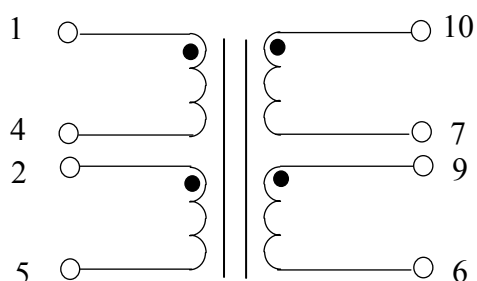

AT5002

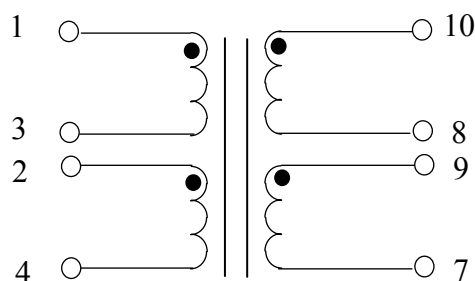

## Dimension

### AT0013/AT0002

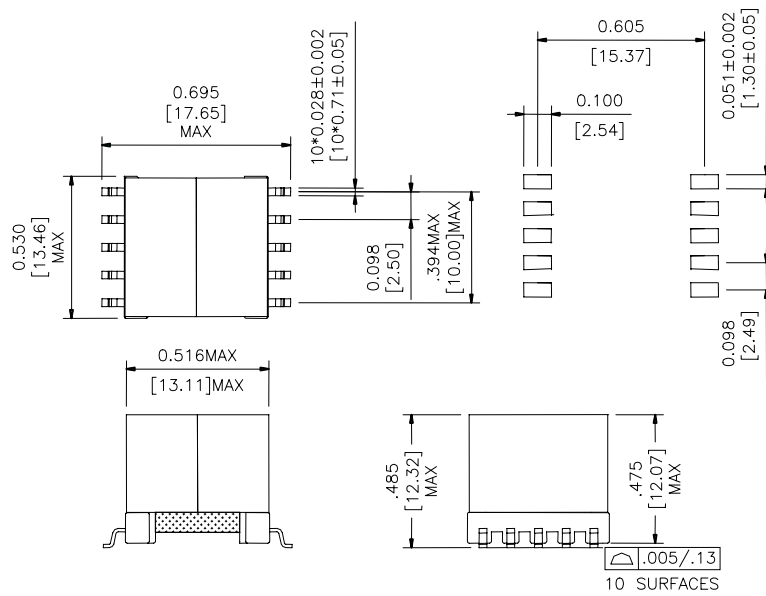

### AT5013/AT5002

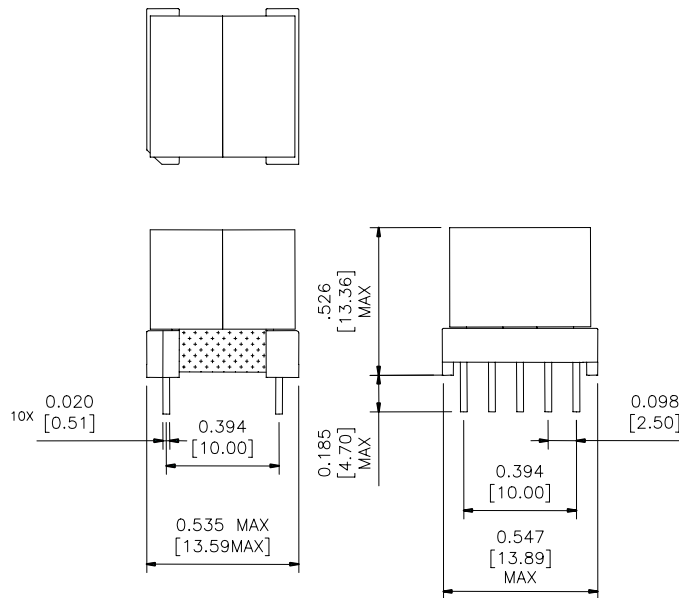

Data sheet subject to change without notice