

10/100 Quad Port Transformer Modules

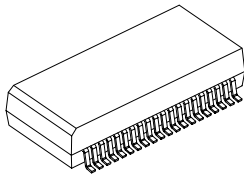

- ★ Designed to meet IEEE802.3u requirement
- ★ Designed to meet IR 235^oC peak requirement
- ★ Primary inductance 350μH min. with 8mA DC Bias
- ★ Quad Port for Hub Application

Specifications										
Part Number	Turn Ratio		Insertion Loss 1~100MHz (dB MAX)	Return Loss (MHz)			CMRR (dB)			Hi-Pot (Vrms MIN)
	Tx	Rx		30MHz	50MHz	80MHz	30MHz	50MHz	100MHz	
HS4013	1:1	1:1	1.0	-21db	-15.5dB	-12dB	-42db	-40dB	-35dB	1500
HS4014	1.25:1	1:1	1.0	-21db	-15.5dB	-12dB	-42db	-40dB	-35dB	1500

Mechanical

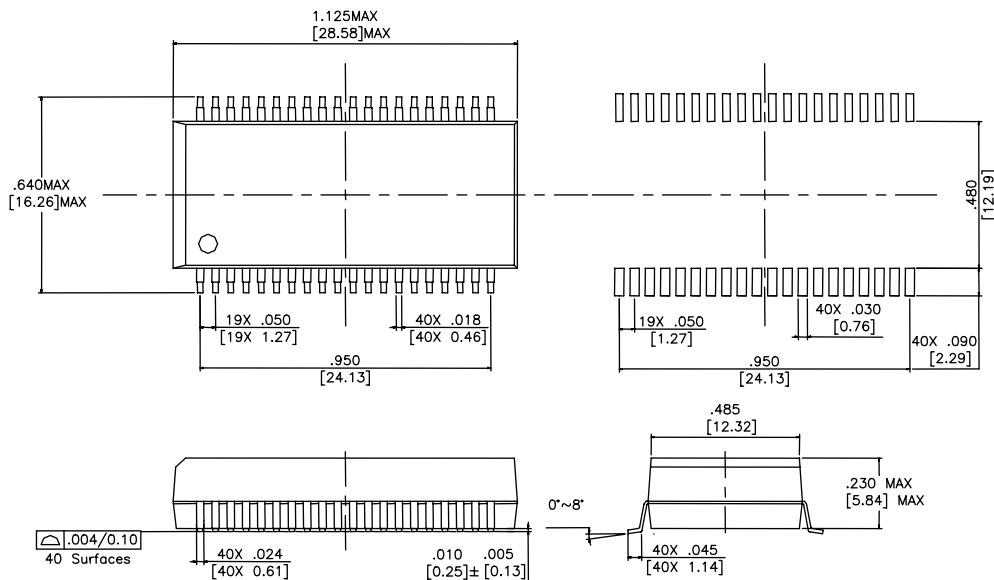

Data sheet subject to change without notice



Best Job!

10/100 Quad Port Transformer Modules



Schematics

HS4013

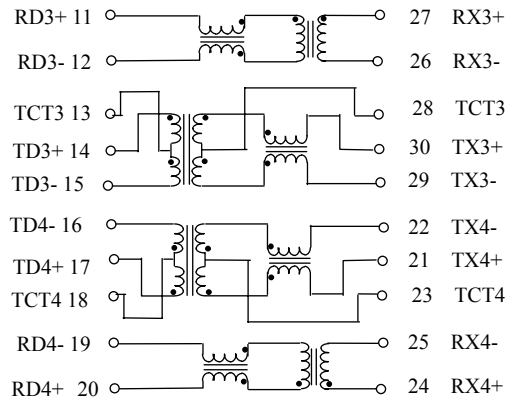
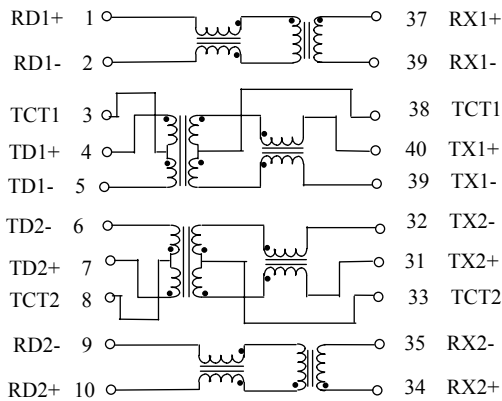

HS4014

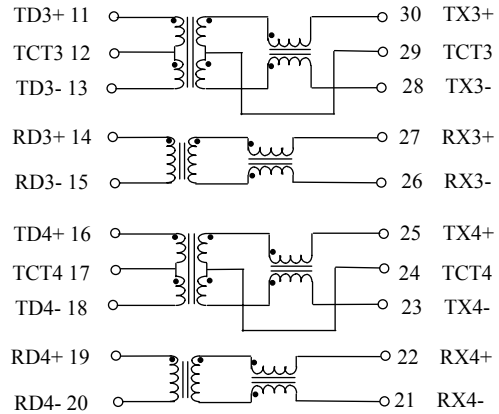
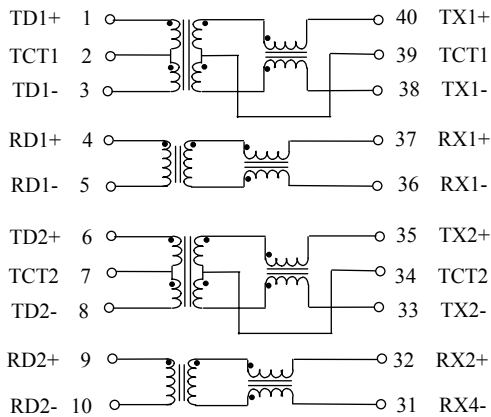

Data sheet subject to change without notice