



### Overview

Tech Kit 2.0 (TK-2.0) includes all components for USB and Bluetooth wireless configuration of the Aperio Open Control Platform. TK-2.0 facilitates Controller Board setup, programming, firmware updates, and firmware restoration. The kit features Blue Ridge Technologies Essentials (BRT Essentials) software on a 1GB flash drive, a Bluetooth Dongle, a Bluetooth Module, a 12'(3.66m) Tech Cable (TC), a screwdriver, and a Carry Bag.

### Features

Configures RI, RK, RP, ZC and CANbus components:  
Satellite  
Capacitive Touch Station (CTS)  
USB and Bluetooth wireless communication  
Complete BRT Essentials software

### Warranty

Two (2) year limited manufacturer warranty from date of shipment (extended warranty optional)

### Computer Requirements

Operating System: Windows 7 (32/64-bit)  
Bluetooth: Microsoft Bluetooth Stack  
USB: Standard-A USB 2.0 port

### Flash Drive Specifications

Capacity: 1GB  
Contents:  
BRT Essentials software  
BRT Essentials Template Files  
USB Drivers  
Supporting Documents

### Bluetooth Specifications

Dongle Connection  
Hardware: Standard-A USB port on computer  
Wireless: Supports multiple device connections  
Module Connection  
Hardware: Bluetooth Plug on Controller Board  
Wireless: PTP connection  
Wireless Type: Bluetooth v2.0+EDR Class 1  
Wireless Range: Open air 328' (100m)  
Wireless Compatibility: BRT Essentials software (API available from Blue Ridge for interface development)

### Tech Cable Specifications

Type: USB 2.0  
Dimensions: 12'(3.66m)L  
Computer Connection: Standard-A USB port  
Controller Board Connection: Micro-B USB port

### Accessory Specifications

Screwdriver  
Type: 0.4 x 2.5mm slot head  
Carry Bag  
Type: Flat cloth with zipper closure  
Dimensions: 7.25"(184mm)H x 9.50"(241mm)W

# Tech Kit 2.0

www.BRTint.com : 800-241-9173 Blue Ridge Technologies® © 2014 Blue Ridge Technologies International, LLC All Rights Reserved. TK20-DS-V14.05

Data Sheet : Catalog Page 93

## General Architecture

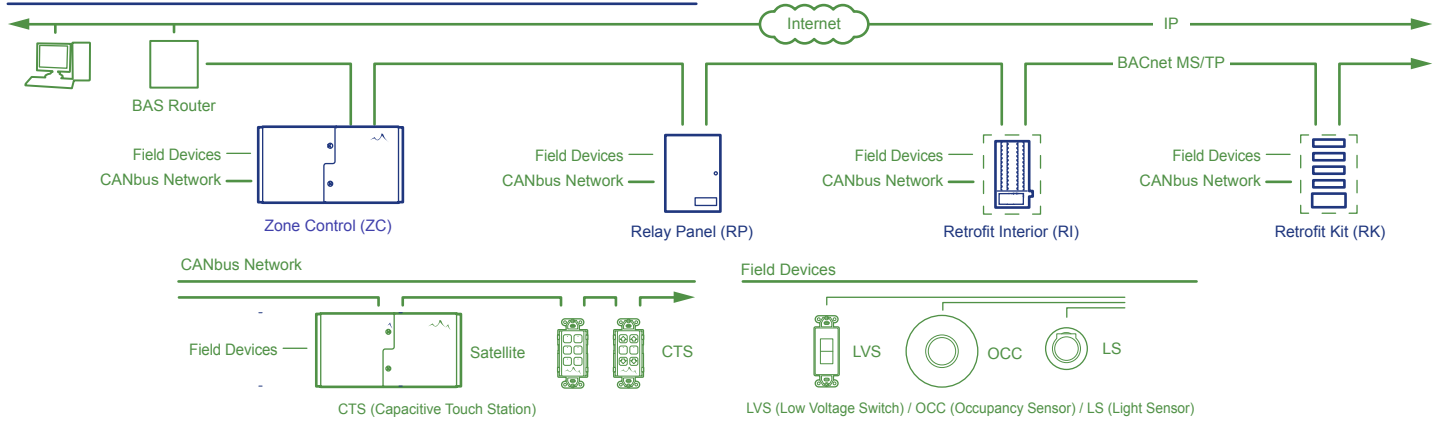

## Controller Board Terminations (ZC)

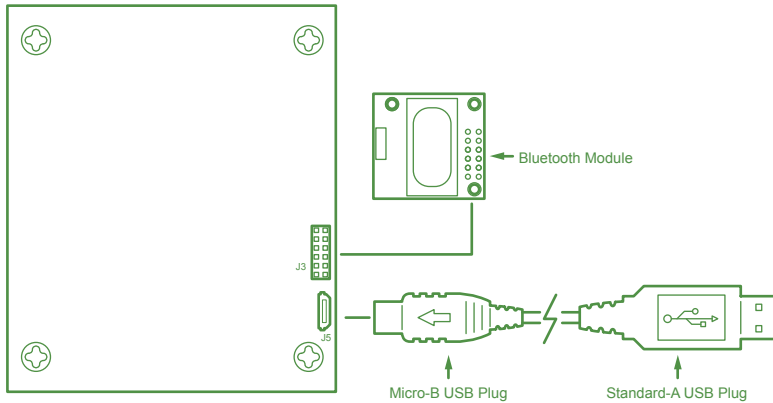

## Controller Board Terminations (RI / RK / RP)

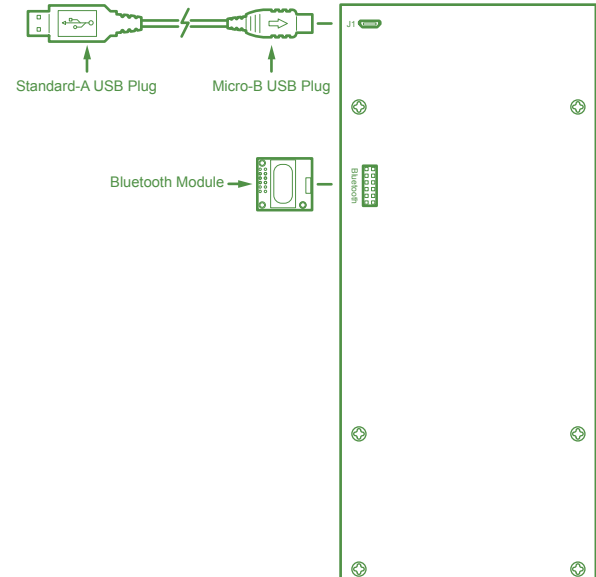

## Ordering Information

Part Number	Description
TK-2.0	Tech Kit 2.0 (Micro-USB Cable, USB flash drive with BRT Essentials software, Bluetooth Dongle, Bluetooth Module, Screwdriver, and Carry Bag)