

# Calconduit™

Rigid Conduit, Rigid, EMT & AL Fittings

---

Product Catalog

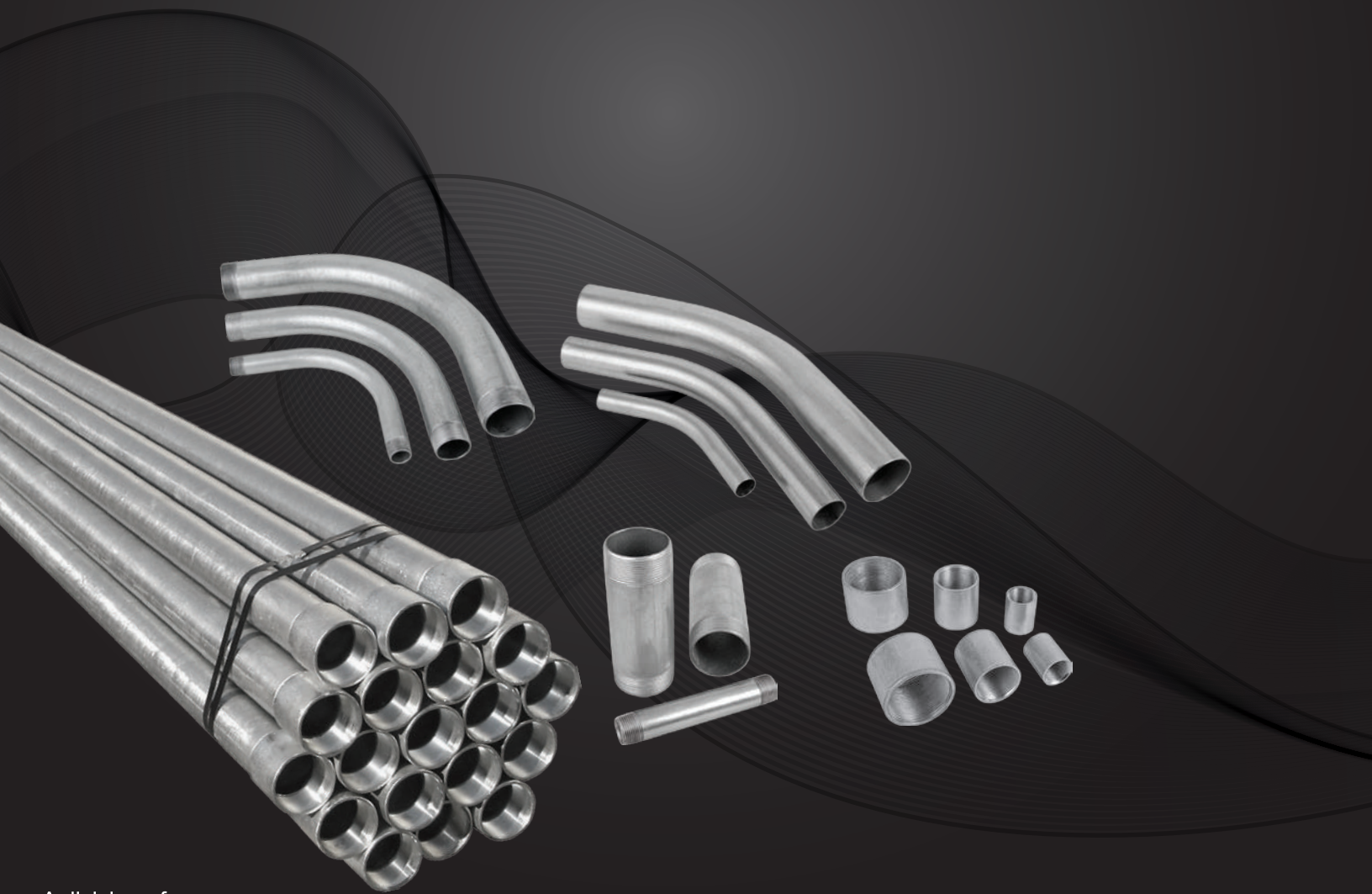

## TABLE OF CONTENTS

### GALVANIZED RIGID CONDUIT & COUPLINGS

Galvanized Rigid Conduit . . . . .	4
Galvanized Rigid Couplings . . . . .	4

### GALVANIZED RIGID FACTORY ELBOWS

90° Galvanized Rigid Factory Elbows . . . . .	5
45° Galvanized Rigid Factory Elbows . . . . .	5

### GALVANIZED RIGID SPECIAL RADIUS SWEEPS

Special Radius 90° Sweeps . . . . .	6
Special Radius 45° Sweeps . . . . .	7

### GALVANIZED RIGID NIPPLES & YARD ELBOWS

Galvanized Rigid Nipples . . . . .	8-9
Galvanized Rigid Yard Elbows . . . . .	9

### EMT FACTORY ELBOWS

EMT 90° Factory Elbows . . . . .	10
EMT 45° Factory Elbows . . . . .	10

### EMT SPECIAL RADIUS SWEEPS

Special Radius 90° Sweeps . . . . .	11
Special Radius 45° Sweeps . . . . .	12

### ALUMINUM RIGID FACTORY ELBOWS

Aluminum Rigid 90° Factory Elbows . . . . .	13
Aluminum Rigid 45° Factory Elbows . . . . .	13

### ALUMINUM RIGID SPECIAL RADIUS SWEEPS

Special Radius 90° Sweeps . . . . .	14
Special Radius 45° Sweeps . . . . .	15



## CONDUIT COAST-TO-COAST

Headquartered in Rancho Dominguez, CA, Calconduit™, a division of Calpipe Industries, Inc., is a leading manufacturer and supplier of galvanized rigid, EMT, and aluminum. With stocking locations throughout the USA, short manufacturing lead times and competitive pricing, Calconduit is focused on quick response to project requirements nationwide.



## FAST, RELIABLE AND RESPONSIVE TEAM

- Our superior customer service team impacts the buying process from specification to shipment.
- With our unique production capabilities, we can accommodate special requests and those "unscheduled" changes to conduit runs that are impossible to produce using field equipment.
- Calconduit makes it easy to do business regardless of your location.

## MADE IN THE USA & ARRA CAPABILITIES

Calconduit's product offering includes domestically manufactured and ARRA-compliant conduit, nipples, and bends available in a wide variety of specifications. For more information regarding custom ARRA solutions, please contact a Calconduit product specialist.

On February 17, 2009, the American Recovery and Reinvestment of 2009 (ARRA) was signed into law. Among the many areas the legislation addresses, ARRA 2009 includes allocations for the construction and renovation of Federal and State buildings. This funding is available for new construction projects, renovations, repairs and sustainability upgrades.

## COMMITMENT TO CUSTOMERS

Calconduit is dedicated to providing customers with quality steel conduit and fittings that meet industry standards and are delivered on a timely basis. We rely on direct personal service, fast response to quotations with competitive pricing and performance to keep our customers coming back.

- 24 to 72 hour turnaround on most production runs and specials
- Competitive pricing and availability for projects nationwide
- With regional inventory throughout the USA, we offer next day delivery in most locations

## CALCONDUIT ... THE BENDING EXPERTS

When presented a project with special requirements, our bending specialists have the experience to produce conduit runs from complex layouts with a turnaround time that meets your schedule. Calconduit has been providing distributors and their customers with special radius sweeps and custom bends for nearly three decades. Whether it's a standard or special requirement, think Calconduit.



### Stub ups

L-shaped conduit  
(90° bend)



### Back-to-back bends

Conduit that turns two  
corners in a 180° bend



### Offset bend

Changes the conduit plane  
to clear obstacles or to  
rise up from a wall to enter  
a junction box



### Three bend saddle

Allows conduit to clear an  
obstacle, maintain alignment  
and appearance

Standard threading & bending capabilities

- Available in galvanized and aluminum rigid and EMT
- Diameters – 1/2" – 6"
- Radii – 12" to 360" in 12" increments

Special large-radii bending capabilities

- Custom segment bends (11-1/4° - 15° - 22-1/2° - 30° - 60°) in a variety of radii
- Large diameter and difficult-to-field bend stubs and offsets
- Large diameter special length nipples

## QUALITY MAKES THE DIFFERENCE

Calconduit's quality assurance program complies with industry standards established by Underwriters' Laboratories (UL), CSA, ASTM, ANSI, NEMA, and other agencies.

**UL listings include:**

Ferrous electrical conduit	File # DYIX.E226472
Electrical metallic tubing	File # FJMX.E315441
Non-Ferrous electrical conduit (aluminum & stainless)	File # DYWV.E230584



## GALVANIZED RIGID CONDUIT Dimension and Weight Chart

Item Number	Trade Size	Nominal Weight / per 100 Ft. w/ couplings	Nominal Outside Dia.	Nominal Wall Thickness	Length w/ Coupling	Bundle Quantities		
	Inches	Pounds	Inches	Inches	Feet	Pieces	Feet	Pounds
ST0510CT00	½"	82	0.840	0.104	10	250	2,500	2,050
ST0710CT00	¾"	109	1.050	0.107	10	200	2,000	2,180
ST1010CT00	1"	161	1.315	0.126	10	125	1,250	2,013
ST1210CT00	1-¼"	218	1.660	0.133	10	90	900	1,962
ST1510CT00	1-½"	263	1.900	0.138	10	80	800	2,104
ST2010CT00	2"	350	2.375	0.146	10	60	600	2,100
ST2510CT00	2-½"	559	2.875	0.193	10	37	370	2,068
ST3010CT00	3"	751	3.500	0.205	10	30	300	2,181
ST3510CT00	3-½"	880	4.000	0.215	10	25	250	2,200
ST4010CT00	4"	1030	4.500	0.225	10	20	200	2,060
ST5010CT00	5"	1400	5.563	0.245	10	15	150	2,100
ST6010CT00	6"	1840	6.625	0.266	10	10	100	1,840

Applicable tolerances: Length: 10Ft ± ¼"  
 Outside Diameter: ½"-2" ±0.015"; 2-½"-4" ±0.025"; 5"-6" ± 1%

### SPECIFICATIONS

Calconduit rigid conduit is manufactured in accordance with the latest edition of the following:  
 American National Standards Institute for rigid steel tubing (ANSI® C80.1)  
 Underwriters Laboratories Standard for rigid steel tubing (UL6)  
 Threads conform to ANSI B1.20.1



## GALVANIZED RIGID COUPLINGS c(UL)us

Item Number	Trade Size	Wt. (lbs)	Box Qty	Length A
ST0500CP00	½"	0.12	100	1.63
ST0700CP00	¾"	0.17	50	1.64
ST1000CP00	1"	0.29	30	1.97
ST1200CP00	1-¼"	0.38	25	2.03
ST1500CP00	1-½"	0.53	25	2.06
ST2000CP00	2"	0.70	20	2.13
ST2500CP00	2-½"	1.80	24	3.19
ST3000CP00	3"	2.26	16	3.31
ST3500CP00	3-½"	3.50	12	3.41
ST4000CP00	4"	3.13	10	3.52
ST5000CP00	5"	4.75	5	3.95
ST6000CP00	6"	7.65	3	4.25

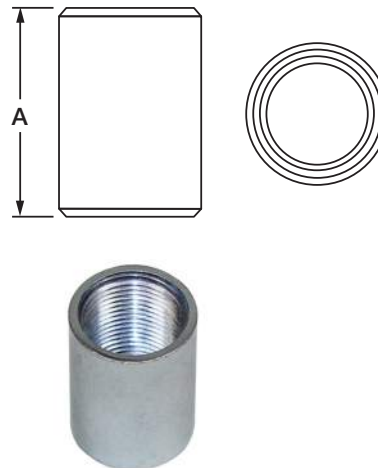

Dimensions listed in inches unless otherwise noted

## GALVANIZED RIGID FACTORY ELBOWS

90° Elbows				Dimensions			
Item Number	Description	Wt. (lbs)	Box Qty	A	B	T	Cut Length
ST0590EL00	½" X 90°	1.00	50	4.0	6.9	2.9	12.0"
ST0790EL00	¾" X 90°	1.30	50	4.5	7.4	2.9	12.9"
ST1090EL00	1" X 90°	2.10	25	5.8	8.7	3.0	15.0"
ST1290EL00	1-¼" X 90°	3.40	20	7.3	10.6	3.3	18.0"
ST1590EL00	1-½" X 90°	4.80	15	8.3	11.9	3.6	20.3"
ST2090EL00	2" X 90°	7.30	10	9.5	13.8	4.3	23.4"
ST2590EL00	2-½" X 90°	13.90	50	10.5	15.8	5.3	27.0"
ST3090EL00	3" X 90°	21.30	35	13.0	18.8	5.8	32.0"
ST3590EL00	3-½" X 90°	27.00	35	15.0	21.8	6.8	37.0"
ST4090EL00	4" X 90°	36.80	35	16.0	23.1	7.1	39.3"
ST5090EL00	5" X 90°	70.00	bulk	24.0	35.2	11.2	60.0"
ST6090EL00	6" X 90°	111.80	bulk	30.0	42.6	12.6	72.3"

Dimensions listed in inches unless otherwise noted

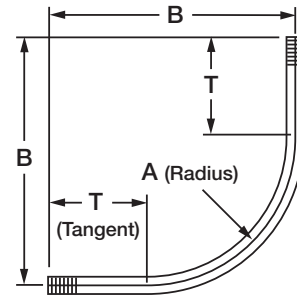

45° Elbows				Dimensions				
Item Number	Description	Wt. (lbs)	Box Qty	A	B	C	T	Cut Length
ST0545EL00	½" X 45°	0.70	50	4.0	7.0	2.9	1.9	8.0"
ST0745EL00	¾" X 45°	0.90	50	4.5	7.4	3.0	2.0	9.0"
ST1045EL00	1" X 45°	1.60	25	5.8	9.5	4.0	2.7	10.0"
ST1245EL00	1-¼" X 45°	2.90	20	7.3	13.1	5.4	4.3	15.5"
ST1545EL00	1-½" X 45°	3.80	15	8.3	14.0	5.8	4.3	16.5"
ST2045EL00	2" X 45°	5.40	10	9.5	16.1	6.6	5.4	18.5"
ST2545EL00	2-½" X 45°	10.80	50	10.5	19.0	7.9	6.8	22.5"
ST3045EL00	3" X 45°	14.70	35	13.0	20.5	8.5	6.7	23.5"
ST3545EL00	3-½" X 45°	19.50	35	15.0	22.8	9.5	7.1	26.0"
ST4045EL00	4" X 45°	29.30	35	16.0	29.2	12.1	10.5	33.5"
ST5045EL00	5" X 45°	50.20	bulk	24.0	36.1	15.0	11.2	43.0"
ST6045EL00	6" X 45°	77.60	bulk	30.0	42.9	17.8	12.8	48.0"

Dimensions listed in inches unless otherwise noted

Dimensional data is for reference only  
 NPT thread on each end  
 Galvanized Rigid Elbows meet UL6 and ANSI C80.1  
 Threads conform to ANSI B1.20.1  
 Also available in 11-1/4°, 15°, 22-1/2°, 30°, and 60°

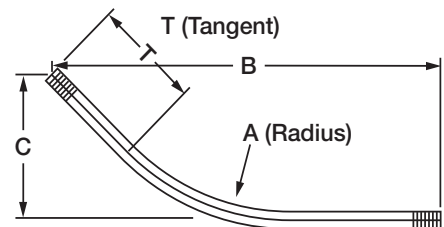

## GALVANIZED RIGID SPECIAL RADIUS 90° SWEEPS <sup>c</sup>UL<sub>US</sub>

### 12" - 18"

		Radius						
A	12 Inch				18 Inch			
Size	Item Number	B	T	Wt.	Item No	B	T	Wt.
½"	ST0512SW90	21	10	2.60	ST0518SW90	28	11	3.60
¾"	ST0712SW90	21	10	3.50	ST0718SW90	28	11	4.70
1"	ST1012SW90	21	10	5.00	ST1018SW90	28	11	6.00
1-¼"	ST1212SW90	21	10	6.00	ST1218SW90	28	11	9.00
1-½"	ST1512SW90	21	10	8.00	ST1518SW90	28	11	11.40
2"					ST2018SW90	28	11	15.20
2-½"					ST2518SW90	28	11	24.30
3"					ST3018SW90	28	11	32.90
3-½"					ST3518SW90	28	11	39.00



### 24" - 30" - 36"

		Radius											
A	24 Inch				30 Inch				36 Inch				
Size	Item Number	B	T	Wt.	Item No	B	T	Wt.	Item No	B	T	Wt.	
½"	ST0524SW90	35	11	4.10	ST0530SW90	41	11	4.90	ST0536SW90	47	11	5.50	
¾"	ST0724SW90	35	11	5.50	ST0730SW90	41	11	6.50	ST0736SW90	47	11	7.30	
1"	ST1024SW90	35	11	8.00	ST1030SW90	41	11	9.00	ST1036SW90	47	11	10.00	
1-¼"	ST1224SW90	35	11	11.00	ST1230SW90	41	11	12.00	ST1236SW90	47	11	14.00	
1-½"	ST1524SW90	35	11	13.20	ST1530SW90	41	11	15.80	ST1536SW90	47	11	17.50	
2"	ST2024SW90	35	11	17.50	ST2030SW90	41	11	21.00	ST2036SW90	47	11	23.30	
2-½"	ST2524SW90	35	11	28.00	ST2530SW90	41	11	33.60	ST2536SW90	47	11	37.30	
3"	ST3024SW90	35	11	38.00	ST3030SW90	41	11	45.60	ST3036SW90	47	11	50.70	
3-½"	ST3524SW90	35	11	45.00	ST3530SW90	41	11	54.00	ST3536SW90	47	11	60.00	
4"	ST4024SW90	35	11	52.50	ST4030SW90	41	11	63.00	ST4036SW90	47	11	70.00	
5"									ST5036SW90	47	11	93.30	
6"									ST6036SW90	48	12	123.30	

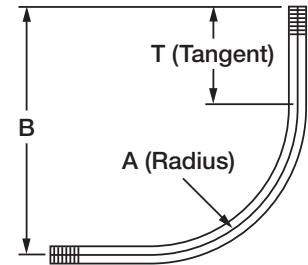

### 42" - 48" - 60"

		Radius											
A	42 Inch				48 Inch				60 Inch				
Size	Item Number	B	T	Wt.	Item No	B	T	Wt.	Item No	B	T	Wt.	
½"	ST0542SW90	54	12	6.20	ST0548SW90	60	12	6.90	ST0560SW90	72	12	8.30	
¾"	ST0742SW90	54	12	8.20	ST0748SW90	60	12	9.10	ST0760SW90	72	12	11.00	
1"	ST1042SW90	54	12	12.00	ST1048SW90	60	12	13.00	ST1060SW90	72	12	15.00	
1-¼"	ST1242SW90	54	12	16.00	ST1248SW90	60	12	18.00	ST1260SW90	72	12	22.00	
1-½"	ST1542SW90	54	12	19.00	ST1548SW90	60	12	21.90	ST1560SW90	72	12	25.00	
2"	ST2042SW90	54	12	26.30	ST2048SW90	60	12	29.20	ST2060SW90	72	12	37.00	
2-½"	ST2542SW90	54	12	42.00	ST2548SW90	60	12	46.70	ST2560SW90	72	12	56.00	
3"	ST3042SW90	54	12	57.00	ST3048SW90	60	12	63.30	ST3060SW90	72	12	76.00	
3-½"					ST3548SW90	60	12	75.00	ST3560SW90	72	12	90.00	
4"					ST4048SW90	60	12	87.50	ST4060SW90	72	12	105.00	
5"					ST5048SW90	60	12	116.70	ST5060SW90	72	12	140.00	
6"					ST6048SW90	60	12	156.00	ST6060SW90	72	12	185.00	

Dimensions listed in inches unless otherwise noted

Dimensional data is for reference only

NPT thread with end-cap on each end

Galvanized Rigid Special Radius 90° Sweeps meet UL6 and ANSI C80.1

Threads conform to ANSI B1.20.1

Also available in 11-1/4°, 15°, 22-1/2°, 30°, and 60°

## GALVANIZED RIGID SPECIAL RADIUS 45° SWEEPS

12" - 18"										
Radius										
A	12 Inch					18 Inch				
Size	Item Number	B	C	T	Wt.	Item Number	B	C	T	Wt.
½"	ST0512SW45	24	10	10	2.10	ST0518SW45	30	12.5	11	2.50
¾"	ST0712SW45	24	10	10	2.50	ST0718SW45	30	12.5	11	3.30
1"	ST1012SW45	24	10	10	3.60	ST1018SW45	30	12.5	11	4.20
1-¼"	ST1212SW45	24	10	10	5.50	ST1218SW45	30	12.5	11	6.10
1-½"	ST1512SW45	24	10	10	8.00	ST1518SW45	30	12.5	11	8.00
2"						ST2018SW45	30	12.5	11	10.00
2-½"						ST2518SW45	30	12.5	11	15.00
3"						ST3018SW45	30	12.5	11	20.00
3-½"						ST3518SW45	30	12.5	11	22.50

24" - 30" - 36"															
Radius															
A	24 Inch					30 Inch					36 Inch				
Size	Item Number	B	C	T	Wt.	Item Number	B	C	T	Wt.	Item No	B	C	T	Wt.
½"	ST0524SW45	36	15	11	2.90	ST0530SW45	40	17	11	3.30	ST0536SW45	44	18.5	11	3.60
¾"	ST0724SW45	36	15	11	3.80	ST0730SW45	40	17	11	4.40	ST0736SW45	44	18.5	11	4.70
1"	ST1024SW45	36	15	11	6.40	ST1030SW45	40	17	11	7.00	ST1036SW45	44	18.5	11	6.20
1-¼"	ST1224SW45	36	15	11	8.00	ST1230SW45	40	17	11	9.00	ST1236SW45	44	18.5	11	9.00
1-½"	ST1524SW45	36	15	11	9.20	ST1530SW45	40	17	11	9.60	ST1536SW45	44	18.5	11	11.00
2"	ST2024SW45	36	15	11	12.00	ST2030SW45	40	17	11	14.00	ST2036SW45	44	18.5	11	14.00
2-½"	ST2524SW45	36	15	11	15.00	ST2530SW45	40	17	11	22.00	ST2536SW45	44	18.5	11	22.00
3"	ST3024SW45	36	15	11	25.00	ST3030SW45	40	17	11	27.00	ST3036SW45	44	18.5	11	29.00
3-½"	ST3524SW45	36	15	11	28.60	ST3530SW45	40	17	11	29.30	ST3536SW45	44	18.5	11	35.00
4"	ST4024SW45	36	15	11	34.00	ST4030SW45	40	17	11	41.00	ST4036SW45	44	18.5	11	42.00
5"											ST5036SW45	44	18.5	11	60.00
6"											ST6036SW45	44	18.5	12	121.00

42" - 48" - 60"															
Radius															
A	42 Inch					48 Inch					60 Inch				
Size	Item Number	B	C	T	Wt.	Item Number	B	C	T	Wt.	Item No	B	C	T	Wt.
½"	ST0542SW45	50	21	12	3.90	ST0548SW45	54.5	22.5	12	4.20	ST0560SW45	62	26	12	4.90
¾"	ST0742SW45	50	21	12	5.20	ST0748SW45	54.5	22.5	12	5.60	ST0760SW45	62	26	12	6.40
1"	ST1042SW45	50	21	12	7.60	ST1048SW45	54.5	22.5	12	8.30	ST1060SW45	62	26	12	9.50
1-¼"	ST1242SW45	50	21	12	10.40	ST1248SW45	54.5	22.5	12	11.30	ST1260SW45	62	26	12	12.90
1-½"	ST1542SW45	50	21	12	12.50	ST1548SW45	54.5	22.5	12	13.60	ST1560SW45	62	26	12	15.60
2"	ST2042SW45	50	21	12	16.60	ST2048SW45	54.5	22.5	12	18.10	ST2060SW45	62	26	12	20.70
2-½"	ST2542SW45	50	21	12	26.60	ST2548SW45	54.5	22.5	12	28.90	ST2560SW45	62	26	12	33.10
3"	ST3042SW45	50	21	12	35.70	ST3048SW45	54.5	22.5	12	38.80	ST3060SW45	62	26	12	44.40
3-½"						ST3548SW45	54.5	22.5	12	45.50	ST3560SW45	62	26	12	52.10
4"						ST4048SW45	54.5	22.5	12	53.20	ST4060SW45	62	26	12	60.90
5"						ST5048SW45	54.5	22.5	12	72.30	ST5060SW45	62	26	12	82.80
6"						ST6048SW45	54.5	22.5	12	93.00	ST6060SW45	62	26	12	106.50

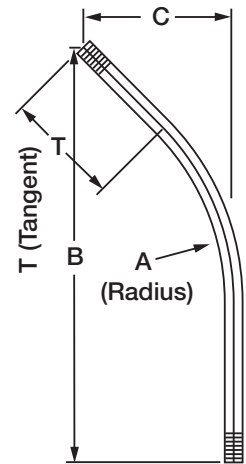

Dimensional data is for reference only  
 NPT thread with end-cap on each end  
 Galvanized Rigid Special Radius 45° Sweeps meet UL6 and ANSI C80.1  
 Threads conform to ANSI B1.20.1  
 Also available in 11-1/4°, 15°, 22-1/2°, 30°, and 60°

## GALVANIZED RIGID NIPPLES

Item Number	Size	Length	Wt. (lbs)	Box Qty
ST05CLCN00	½" X CL	1-⅛"	0.05	25
ST0515CN00	½" X 1-½"	1-½"	0.08	25
ST0520CN00	½" X 2"	2"	0.10	25
ST0525CN00	½" X 2-½"	2-½"	0.14	25
ST0530CN00	½" X 3"	3"	0.18	25
ST0535CN00	½" X 3-½"	3-½"	0.22	25
ST0540CN00	½" X 4"	4"	0.24	25
ST0550CN00	½" X 5"	5"	0.30	25
ST0560CN00	½" X 6"	6"	0.40	25
ST0580CN00	½" X 8"	8"	0.51	25
ST0510CN00	½" X 10"	10"	0.68	25
ST0512CN00	½" X 12"	12"	0.80	25
ST07CLCN00	¾" X CL	1-⅜"	0.08	25
ST0715CN00	¾" X 1-½"	1-½"	0.09	25
ST0720CN00	¾" X 2"	2"	0.13	25
ST0725CN00	¾" X 2-½"	2-½"	0.19	25
ST0730CN00	¾" X 3"	3"	0.23	25
ST0735CN00	¾" X 3-½"	3-½"	0.28	25
ST0740CN00	¾" X 4"	4"	0.33	25
ST0745CN00	¾" X 4-½"	4-½"	0.38	25
ST0750CN00	¾" X 5"	5"	0.40	25
ST0760CN00	¾" X 6"	6"	0.50	25
ST0780CN00	¾" X 8"	8"	0.73	25
ST0710CN00	¾" X 10"	10"	0.84	25
ST0712CN00	¾" X 12"	12"	1.08	25
ST10CLCN00	1" X CL	1-½"	0.16	25
ST1020CN00	1" X 2"	2"	0.20	25
ST1025CN00	1" X 2-½"	2-½"	0.27	25
ST1030CN00	1" X 3"	3"	0.34	25
ST1035CN00	1" X 3-½"	3-½"	0.41	25
ST1040CN00	1" X 4"	4"	0.47	25
ST1045CN00	1" X 4-½"	4-½"	0.53	25
ST1050CN00	1" X 5"	5"	0.63	25
ST1060CN00	1" X 6"	6"	0.75	25
ST1080CN00	1" X 8"	8"	1.09	25
ST1010CN00	1" X 10"	10"	1.38	25
ST1012CN00	1" X 12"	12"	1.47	25

Dimensional data is for reference only

NPT thread on each end  
Galvanized Rigid Nipples meet UL6 and ANSI C80.1  
Threads conform to ANSI B1.20.1

Prices are available upon request for nipples in lengths longer than 12" or special threads

Item Number	Size	Length	Wt. (lbs)	Box Qty
ST12CLCN00	1-¼" X CL	1-⅝"	0.19	25
ST1220CN00	1-¼" X 2"	2"	0.25	25
ST1225CN00	1-¼" X 2-½"	2-½"	0.34	25
ST1230CN00	1-¼" X 3"	3"	0.44	25
ST1235CN00	1-¼" X 3-½"	3-½"	0.55	25
ST1240CN00	1-¼" X 4"	4"	0.62	25
ST1245CN00	1-¼" X 4-½"	4-½"	0.80	25
ST1250CN00	1-¼" X 5"	5"	0.80	25
ST1260CN00	1-¼" X 6"	6"	1.00	25
ST1280CN00	1-¼" X 8"	8"	1.36	25
ST1210CN00	1-¼" X 10"	10"	1.82	40
ST1212CN00	1-¼" X 12"	12"	1.97	30
ST15CLCN00	1-½" X CL	1-¾"	0.24	25
ST1520CN00	1-½" X 2"	2"	0.28	25
ST1525CN00	1-½" X 2-½"	2-½"	0.36	25
ST1530CN00	1-½" X 3"	3"	0.48	25
ST1535CN00	1-½" X 3-½"	3-½"	0.68	25
ST1540CN00	1-½" X 4"	4"	0.77	25
ST1550CN00	1-½" X 5"	5"	0.97	25
ST1560CN00	1-½" X 6"	6"	1.13	50
ST1580CN00	1-½" X 8"	8"	1.53	40
ST1510CN00	1-½" X 10"	10"	1.94	30
ST1512CN00	1-½" X 12"	12"	2.60	20
ST20CLCN00	2" X CL	2"	0.38	25
ST2025CN00	2" X 2-½"	2-½"	0.59	25
ST2030CN00	2" X 3"	3"	0.62	25
ST2035CN00	2" X 3-½"	3-½"	0.88	40
ST2040CN00	2" X 4"	4"	0.90	40
ST2050CN00	2" X 5"	5"	1.32	40
ST2060CN00	2" X 6"	6"	1.46	30
ST2080CN00	2" X 8"	8"	2.20	20
ST2010CN00	2" X 10"	10"	2.85	15
ST2012CN00	2" X 12"	12"	3.02	15





## GALVANIZED RIGID NIPPLES

Item Number	Size	Length	Wt. (lbs)	Box Qty
ST25CLCN00	2-½" X CL	2-½"	0.84	40
ST2530CN00	2-½" X 3"	3"	1.00	40
ST2535CN00	2-½" X 3-½"	3-½"	1.20	30
ST2540CN00	2-½" X 4"	4"	1.50	30
ST2550CN00	2-½" X 5"	5"	1.97	20
ST2560CN00	2-½" X 6"	6"	2.40	20
ST2580CN00	2-½" X 8"	8"	3.29	10
ST2510CN00	2-½" X 10"	10"	4.22	10
ST2512CN00	2-½" X 12"	12"	5.05	10
ST30CLCN00	3" X CL	2-5/8"	1.18	30
ST3030CN00	3" X 3"	3"	1.30	20
ST3035CN00	3" X 3-½"	3-½"	1.57	15
ST3040CN00	3" X 4"	4"	2.00	15
ST3050CN00	3" X 5"	6"	2.60	15
ST3060CN00	3" X 6"	8"	3.00	10
ST3080CN00	3" X 8"	10"	4.11	7
ST3010CN00	3" X 10"	12"	5.28	5
ST3012CN00	3" X 12"	12"	6.30	5
ST35CLCN00	3-½" X CL	2-¾"	1.60	20
ST3540CN00	3-½" X 4"	4"	2.40	10
ST3550CN00	3-½" X 5"	5"	3.20	8
ST3560CN00	3-½" X 6"	6"	3.73	8
ST3580CN00	3-½" X 8"	8"	5.10	4
ST3510CN00	3-½" X 10"	10"	6.55	4
ST3512CN00	3-½" X 12"	12"	7.85	4

Item Number	Size	Length	Wt. (lbs)	Box Qty
ST40CLCN00	4" X CL	2-7/8"	1.80	20
ST4040CN00	4" X 4"	4"	2.85	10
ST4050CN00	4" X 5"	5"	3.80	8
ST4060CN00	4" X 6"	6"	4.40	8
ST4080CN00	4" X 8"	8"	6.00	4
ST4010CN00	4" X 10"	10"	7.75	4
ST4012CN00	4" X 12"	12"	9.25	4
ST50CLCN00	5" X CL	3"	2.40	5
ST5050CN00	5" X 5"	5"	4.80	5
ST5060CN00	5" X 6"	6"	6.00	5
ST5080CN00	5" X 8"	8"	8.25	4
ST5010CN00	5" X 10"	10"	10.55	3
ST5012CN00	5" X 12"	12"	12.60	3
ST60CLCN00	6" X CL	3-1/8"	3.50	5
ST6050CN00	6" X 5"	5"	6.60	5
ST6060CN00	6" X 6"	6"	8.20	5
ST6080CN00	6" X 8"	8"	10.40	4
ST6010CN00	6" X 10"	10"	14.40	3
ST6012CN00	6" X 12"	12"	17.20	3

Dimensional data is for reference only

NPT thread on each end

Galvanized Rigid Nipples meet UL6 and ANSI C80.1  
Threads conform to ANSI B1.20.1

Prices are available upon request for nipples in lengths longer than 12" or special threads

## GALVANIZED RIGID YARD ELBOWS

Item Number	Description	Wt. (lbs)	Dimensions (Inches)				
			A	B	C	D	E
ST0590YL00	½" X 90°	1.40	4"	18"	6.19"	2.19"	14"
ST0790YL00	¾" X 90°	1.90	4.50"	18"	6.75"	2.25"	13.50"
ST1090YL00	1" X 90°	3.00	5.75"	18"	8.63"	2.88"	12.25"
ST1290YL00	1-¼" X 90°	4.80	7.25"	19.25"	10.25"	3.25"	12.25"
ST1590YL00	1-½" X 90°	6.30	8.25"	20.50"	11.63"	3.38"	12.25"
ST2090YL00	2" X 90°	9.00	9.50"	21.50"	14.50"	5"	12"
ST2590YL00	2-½" X 90°	14.50	10.50"	22.50"	16"	5.50"	12"
ST3090YL00	3" X 90°	21.20	13"	25"	19.25"	6.25"	12"
ST3590YL00	3-½" X 90°	28.30	15"	27"	22.75"	7.75"	12"
ST4090YL00	4" X 90°	35.00	16"	28"	24"	8"	12"

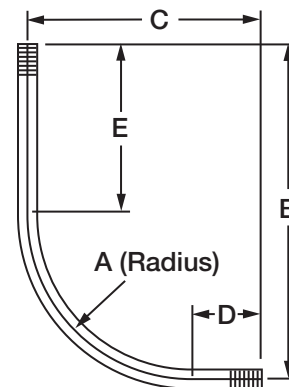

Dimensional data is for reference only

NPT thread with end-cap on each end

Galvanized Rigid Yard Elbows meet UL6 and ANSI C80.1  
Threads conform to ANSI B1.20.1

## EMT FACTORY ELBOWS

90° Factory Elbows				Dimensions (inches)			
Item Number	Description	Wt. (lbs)	Box Qty	A	B	T	Cut Length
EM0590EL00	½" X 90°	0.26	50	4.0	6.9	2.9	12.0
EM0790EL00	¾" X 90°	0.46	50	4.5	7.4	2.9	12.9
EM1090EL00	1" X 90°	0.92	25	5.8	8.7	3.0	15.0
EM1290EL00	1-¼" X 90°	1.35	20	7.3	10.6	3.3	18.0
EM1590EL00	1-½" X 90°	2.00	15	8.3	11.9	3.6	20.3
EM2090EL00	2" X 90°	2.80	10	9.5	13.8	4.3	23.4
EM2590EL00	2-½" X 90°	5.00	50	10.5	15.8	5.3	27.0
EM3090EL00	3" X 90°	7.50	35	13.0	18.8	5.8	32.0
EM3590EL00	3-½" X 90°	10.14	35	15.0	21.8	6.8	37.0
EM4090EL00	4" X 90°	13.00	35	16.0	23.1	7.1	39.3

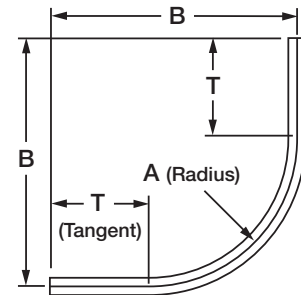

45° Elbows				Dimensions (Inches)				
Item Number	Description	Wt. (lbs)	Box Qty	A	B	C	T	Cut Length
EM0545EL00	½" X 45°	0.24	50	4.0	7.0	2.9	1.9	8.0
EM0745EL00	¾" X 45°	0.40	50	4.5	7.4	3.0	2.0	9.0
EM1045EL00	1" X 45°	0.72	25	5.8	9.5	4.0	2.7	10.0
EM1245EL00	1-¼" X 45°	1.00	20	7.3	13.1	5.4	4.3	15.5
EM1545EL00	1-½" X 45°	1.47	15	8.3	14.0	5.8	4.3	16.5
EM2045EL00	2" X 45°	2.10	10	9.5	16.1	6.6	5.4	18.5
EM2545EL00	2-½" X 45°	3.58	50	10.5	19.0	7.9	6.8	22.5
EM3045EL00	3" X 45°	7.00	35	13.0	20.5	8.5	6.7	23.5
EM3545EL00	3-½" X 45°	8.50	35	15.0	22.8	9.5	7.1	26.0
EM4045EL00	4" X 45°	10.00	35	16.0	29.2	12.1	10.5	33.5

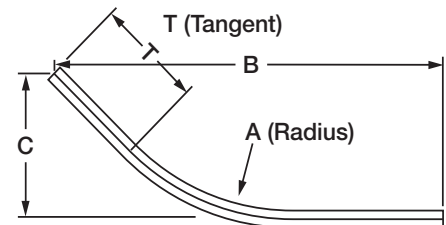

Dimensional data is for reference only

EMT Elbows meet UL797 and ANSI C80.3  
Also available in 11-¼°, 15°, 22-½°, 30° and 60°.

## EMT SPECIAL RADIUS 90° SWEEPS

12"				
Radius				
A	12 Inch			
Size	Item Number	B	T	Wt.
½"	EM0512SW90	21	10	1.00
¾"	EM0712SW90	21	10	1.50
1"	EM1012SW90	21	10	2.10
1-¼"	EM1212SW90	21	10	2.80
1-½"	EM1512SW90	21	10	3.50



24" - 30" - 36"												
Radius												
A	24 Inch				30 Inch				36 Inch			
Size	Item Number	B	T	Wt.	Item No	B	T	Wt.	Item No	B	T	Wt.
½"	EM0524SW90	35	11	1.50	EM0530SW90	41	11	1.80	EM0536SW90	47	11	2.00
¾"	EM0724SW90	35	11	2.30	EM0730SW90	41	11	2.80	EM0736SW90	47	11	3.10
1"	EM1024SW90	35	11	3.30	EM1030SW90	41	11	3.70	EM1036SW90	47	11	4.20
1-¼"	EM1224SW90	35	11	5.10	EM1230SW90	41	11	5.60	EM1236SW90	47	11	6.50
1-½"	EM1524SW90	35	11	5.80	EM1530SW90	41	11	7.00	EM1536SW90	47	11	7.70
2"	EM2024SW90	35	11	7.40	EM2030SW90	41	11	8.90	EM2036SW90	47	11	9.90
2-½"	EM2524SW90	35	11	10.80	EM2530SW90	41	11	12.90	EM2536SW90	47	11	14.40
3"	EM3024SW90	35	11	13.30	EM3030SW90	41	11	16.00	EM3036SW90	47	11	17.70
3-½"	EM3524SW90	35	11	17.80	EM3530SW90	41	11	21.40	EM3536SW90	47	11	23.80
4"	EM4024SW90	35	11	20.00	EM4030SW90	41	11	24.00	EM4036SW90	47	11	26.70

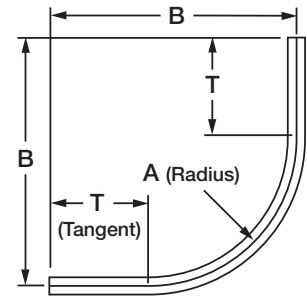

42" - 48" - 60"												
Radius												
A	42 Inch				48 Inch				60 Inch			
Size	Item Number	B	T	Wt.	Item No	B	T	Wt.	Item No	B	T	Wt.
½"	EM0542SW90	54	12	2.30	EM0548SW90	60	12	2.50	EM0560SW90	72	12	3.00
¾"	EM0742SW90	54	12	3.50	EM0748SW90	60	12	3.90	EM0760SW90	72	12	4.60
1"	EM1042SW90	54	12	5.00	EM1048SW90	60	12	5.40	EM1060SW90	72	12	6.20
1-¼"	EM1242SW90	54	12	7.40	EM1248SW90	60	12	8.30	EM1260SW90	72	12	10.20
1-½"	EM1542SW90	54	12	8.40	EM1548SW90	60	12	9.70	EM1560SW90	72	12	11.00
2"	EM2042SW90	54	12	11.10	EM2048SW90	60	12	12.30	EM2060SW90	72	12	15.60
2-½"	EM2542SW90	54	12	16.20	EM2548SW90	60	12	17.90	EM2560SW90	72	12	21.50
3"	EM3042SW90	54	12	20.00	EM3048SW90	60	12	22.20	EM3060SW90	72	12	26.60
3-½"	EM3542SW90	54	12	26.80	EM3548SW90	60	12	29.70	EM3560SW90	72	12	35.70
4"	EM4042SW90	54	12	30.00	EM4048SW90	60	12	33.40	EM4060SW90	72	12	40.10

EMT Sweeps meet UL797 and ANSI C80.3  
 Also available in 11-¼°, 15°, 22-½°, 30° and 60°.

## EMT SPECIAL RADIUS 45° SWEEPS

12"					
Radius					
A	12 Inch				
Size	Item Number	B	C	T	Wt.
½"	EM0512SW45	24	10	10	0.80
¾"	EM0712SW45	24	10	10	1.10
1"	EM1012SW45	24	10	10	1.50
1-¼"	EM1212SW45	24	10	10	2.50
1-½"	EM1512SW45	24	10	10	3.50

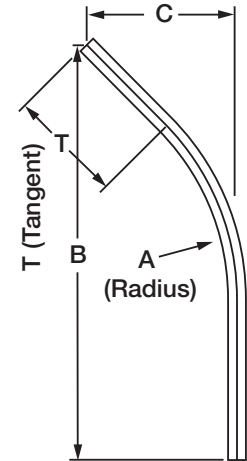

24" - 30" - 36"															
Radius															
A	24 Inch					30 Inch					36 Inch				
Size	Item Number	B	C	T	Wt.	Item No	B	C	T	Wt.	Item No	B	C	T	Wt.
½"	EM0524SW45	36	15	11	1.10	EM0530SW45	40	17	11	1.20	EM0536SW45	44	18.5	11	1.30
¾"	EM0724SW45	36	15	11	1.60	EM0730SW45	40	17	11	1.80	EM0736SW45	44	18.5	11	2.00
1"	EM1024SW45	36	15	11	2.70	EM1030SW45	40	17	11	2.90	EM1036SW45	44	18.5	11	2.60
1-¼"	EM1224SW45	36	15	11	3.70	EM1230SW45	40	17	11	4.20	EM1236SW45	44	18.5	11	4.10
1-½"	EM1524SW45	36	15	11	4.10	EM1530SW45	40	17	11	4.60	EM1536SW45	44	18.5	11	5.10
2"	EM2024SW45	36	15	11	5.10	EM2030SW45	40	17	11	5.90	EM2036SW45	44	18.5	11	5.90
2-½"	EM2524SW45	36	15	11	5.80	EM2530SW45	40	17	11	8.50	EM2536SW45	44	18.5	11	8.50
3"	EM3024SW45	36	15	11	8.80	EM3030SW45	40	17	11	9.50	EM3036SW45	44	18.5	11	10.20
3-½"	EM3524SW45	36	15	11	11.30	EM3530SW45	40	17	11	11.60	EM3536SW45	44	18.5	11	13.90
4"	EM4024SW45	36	15	11	13.00	EM4030SW45	40	17	11	15.60	EM4036SW45	44	18.5	11	16.00

42" - 48" - 60"															
Radius															
A	42 Inch					48 Inch					60 Inch				
Size	Item Number	B	C	T	Wt.	Item No	B	C	T	Wt.	Item No	B	C	T	Wt.
½"	EM0542SW45	50	21	12	1.40	EM0548SW45	54.5	22.5	12	1.60	EM0560SW45	62	26	12	1.80
¾"	EM0742SW45	50	21	12	2.20	EM0748SW45	54.5	22.5	12	2.40	EM0760SW45	62	26	12	2.70
1"	EM1042SW45	50	21	12	3.20	EM1048SW45	54.5	22.5	12	3.50	EM1060SW45	62	26	12	4.00
1-¼"	EM1242SW45	50	21	12	4.80	EM1248SW45	54.5	22.5	12	5.20	EM1260SW45	62	26	12	6.00
1-½"	EM1542SW45	50	21	12	5.50	EM1548SW45	54.5	22.5	12	6.00	EM1560SW45	62	26	12	6.90
2"	EM2042SW45	50	21	12	7.00	EM2048SW45	54.5	22.5	12	7.60	EM2060SW45	62	26	12	8.80
2-½"	EM2542SW45	50	21	12	10.20	EM2548SW45	54.5	22.5	12	11.10	EM2560SW45	62	26	12	12.70
3"	EM3042SW45	50	21	12	12.50	EM3048SW45	54.5	22.5	12	13.60	EM3060SW45	62	26	12	15.60
3-½"	EM3542SW45	50	21	12	16.60	EM3548SW45	54.5	22.5	12	18.00	EM3560SW45	62	26	12	20.60
4"	EM4042SW45	50	21	12	18.70	EM4048SW45	54.5	22.5	12	20.30	EM4060SW45	62	26	12	23.30

EMT Sweeps meet UL797 and ANSI C80.3  
 Also available in 11-¼°, 15°, 22-½°, 30° and 60°.

## ALUMINUM RIGID FACTORY ELBOWS

90° Elbows				Dimensions			
Item Number	Description	Wt. (lbs)	Box Qty.	A	B	T	Cut Length
AR0590EL00	1/2" X 90°	0.30	50	4.0	6.9	2.9	12.0"
AR0790EL00	3/4" X 90°	0.40	50	4.5	7.4	2.9	12.9"
AR1090EL00	1" X 90°	0.70	25	5.8	8.7	3.0	15.0"
AR1290EL00	1-1/4" X 90°	1.10	20	7.3	10.6	3.3	18.0"
AR1590EL00	1-1/2" X 90°	1.50	15	8.3	11.9	3.6	20.3"
AR2090EL00	2" X 90°	2.10	10	9.5	13.8	4.3	23.4"
AR2590EL00	2-1/2" X 90°	5.00	50	10.5	15.8	5.3	27.0"
AR3090EL00	3" X 90°	8.00	35	13.0	18.8	5.8	32.0"
AR3590EL00	3-1/2" X 90°	9.00	35	15.0	21.8	6.8	37.0"
AR4090EL00	4" X 90°	12.00	35	16.0	23.1	7.1	39.3"
AR5090EL00	5" X 90°	24.00	bulk	24.0	35.2	11.2	60.0"
AR6090EL00	6" X 90°	38.00	bulk	30.0	42.6	12.6	72.3"

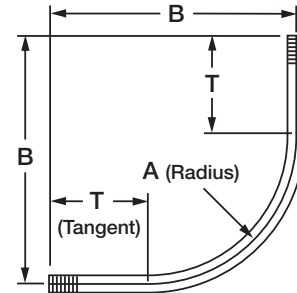

45° Elbows				Dimensions				
Item Number	Description	Wt. (lbs)	Box Qty	A	B	C	T	Cut Length
AR0545EL00	1/2" X 45°	0.20	50	4.0	7.0	2.9	1.9	8.0"
AR0745EL00	3/4" X 45°	0.30	50	4.5	7.4	3.0	2.0	9.0"
AR1045EL00	1" X 45°	0.50	25	5.8	9.5	4.0	2.7	10.0"
AR1245EL00	1-1/4" X 45°	0.90	20	7.3	13.1	5.4	4.3	15.5"
AR1545EL00	1-1/2" X 45°	1.20	15	8.3	14.0	5.8	4.3	16.5"
AR2045EL00	2" X 45°	1.60	10	9.5	16.1	6.6	5.4	18.5"
AR2545EL00	2-1/2" X 45°	3.90	50	10.5	19.0	7.9	6.8	22.5"
AR3045EL00	3" X 45°	5.50	35	13.0	20.5	8.5	6.7	23.5"
AR3545EL00	3-1/2" X 45°	6.50	35	15.0	22.8	9.5	7.1	26.0"
AR4045EL00	4" X 45°	9.60	35	16.0	29.2	12.1	10.5	33.5"
AR5045EL00	5" X 45°	17.20	bulk	24.0	36.1	15.0	11.2	43.0"
AR6045EL00	6" X 45°	26.40	bulk	30.0	42.9	17.8	12.8	48.0"

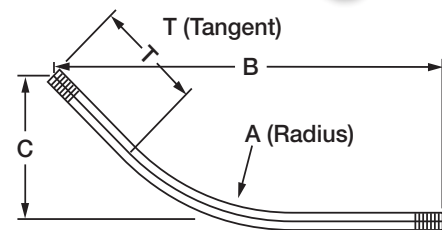

Dimensions listed in inches unless otherwise noted  
 Dimensional data is for reference only  
 NPT thread on each end  
 Aluminum Rigid Elbows meet UL6A and ANSI C80.5

## ALUMINUM RIGID SPECIAL RADIUS 90° SWEEPS

### 12" - 15" - 18"

		Radius											
A	12 Inch				15 Inch				18 Inch				
Size	Item Number	B	T	Wt.	Item Number	B	T	Wt.	Item Number	B	T	Wt.	
1"	AR1012SW90	21	10	1.00	AR1015SW90	24	10	2.00	AR1018SW90	28	11	2.00	
1¼"	AR1212SW90	21	10	2.00	AR1215SW90	24	10	3.00	AR1218SW90	28	11	3.00	
1½"	AR1512SW90	21	10	3.00	AR1515SW90	24	10	3.00	AR1518SW90	28	11	4.00	
2"	AR2012SW90	21	10	4.00	AR2015SW90	24	10	3.00	AR2018SW90	28	11	4.00	
2½"	AR2512SW90	21	10	6.00	AR2515SW90	24	10	7.00	AR2518SW90	28	11	6.00	
3"					AR3015SW90	24	10	9.00	AR3018SW90	28	11	8.00	
3½"									AR3518SW90	28	11	11.00	
4"									AR4018SW90	28	11	14.00	

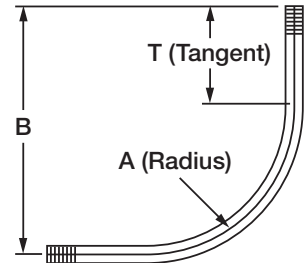

### 24" - 30" - 36"

		Radius											
A	24 Inch				30 Inch				36 Inch				
Size	Item No	B	T	Wt.	Item Number	B	T	Wt.	Item Number	B	T	Wt.	
1"	AR1024SW90	35	11	3.00	AR1030SW90	41	11	3.00	AR1036SW90	47	11	4.00	
1¼"	AR1224SW90	35	11	3.00	AR1230SW90	41	11	4.00	AR1236SW90	47	11	5.00	
1½"	AR1524SW90	35	11	4.00	AR1530SW90	41	11	5.00	AR1536SW90	47	11	6.00	
2"	AR2024SW90	35	11	5.00	AR2030SW90	41	11	7.00	AR2036SW90	47	11	8.00	
2½"	AR2524SW90	35	11	8.00	AR2530SW90	41	11	10.00	AR2536SW90	47	11	12.00	
3"	AR3024SW90	35	11	11.00	AR3030SW90	41	11	13.00	AR3036SW90	47	11	16.00	
3½"	AR3524SW90	35	11	14.00	AR3530SW90	41	11	16.00	AR3536SW90	47	11	19.00	
4"	AR4024SW90	35	11	16.00	AR4030SW90	41	11	19.00	AR4036SW90	47	11	23.00	
5"					AR5030SW90	41	11	29.00	AR5036SW90	47	11	34.00	
6"									AR6036SW90	48	12	42.00	

### 48" - 60"

		Radius							
A	48 Inch				60 Inch				
Size	Item Number	B	T	Wt.	Item Number	B	T	Wt.	
1"	AR1048SW90	60	12	5.00	AR1060SW90	72	12	6.00	
1¼"	AR1248SW90	60	12	6.00	AR1260SW90	72	12	8.00	
1½"	AR1548SW90	60	12	8.00	AR1560SW90	72	12	10.00	
2"	AR2048SW90	60	12	10.00	AR2060SW90	72	12	13.00	
2½"	AR2548SW90	60	12	16.00	AR2560SW90	72	12	20.00	
3"	AR3048SW90	60	12	21.00	AR3060SW90	72	12	27.00	
3½"	AR3548SW90	60	12	25.00	AR3560SW90	72	12	32.00	
4"	AR4048SW90	60	12	29.00	AR4060SW90	72	12	38.00	
5"	AR5048SW90	60	12	44.00	AR5060SW90	72	12	50.00	
6"	AR6048SW90	60	12	58.00	AR6060SW90	72	12	67.00	

Dimensional data is for reference only

NPT thread with end-cap on each end

Aluminum Rigid Sweeps meet UL6 and ANSI C80.5

## ALUMINUM RIGID SPECIAL RADIUS 45° SWEEPS

### 12" - 15" - 18"

		Radius													
A	12 Inch					15 Inch					18 Inch				
Size	Item No	B	C	T	Wt.	Item No	B	C	T	Wt.	Item No	B	C	T	Wt.
1"	AR1012SW45	24	10	10	1.30	AR1015SW45	26	11	10	1.50	AR1018SW45	30	12.5	11	1.50
1¼"	AR1212SW45	24	10	10	1.90	AR1215SW45	26	11	10	1.90	AR1218SW45	30	12.5	11	2.20
1½"	AR1512SW45	24	10	10	2.90	AR1515SW45	26	11	10	2.90	AR1518SW45	30	12.5	11	2.90
2"	AR2012SW45	24	10	10	2.80	AR2015SW45	26	11	10	3.10	AR2018SW45	30	12.5	11	3.60
2½"	AR2512SW45	24	10	10	3.90	AR2515SW45	26	11	10	4.60	AR2518SW45	30	12.5	11	5.40
3"						AR3015SW45	26	11	10	6.10	AR3018SW45	30	12.5	11	7.20
3½"											AR3518SW45	30	12.5	11	8.10
4"											AR4018SW45	30	12.5	11	10.00

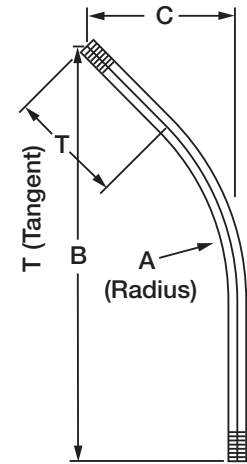

### 24" - 30" - 36"

		Radius													
A	24 Inch					30 Inch					36 Inch				
Size	Item No	B	C	T	Wt.	Item No	B	C	T	Wt.	Item No	B	C	T	Wt.
1"	AR1024SW45	36	15	11	2.30	AR1030SW45	40	17	11	2.50	AR1036SW45	44	18.5	11	2.70
1¼"	AR1224SW45	36	15	11	3.00	AR1230SW45	40	17	11	3.20	AR1236SW45	44	18.5	11	3.20
1½"	AR1524SW45	36	15	11	3.00	AR1530SW45	40	17	11	3.40	AR1536SW45	44	18.5	11	3.90
2"	AR2024SW45	36	15	11	4.30	AR2030SW45	40	17	11	5.00	AR2036SW45	44	18.5	11	5.00
2½"	AR2524SW45	36	15	11	5.40	AR2530SW45	40	17	11	8.00	AR2536SW45	44	18.5	11	7.90
3"	AR3024SW45	36	15	11	9.00	AR3030SW45	40	17	11	9.70	AR3036SW45	44	18.5	11	10.00
3½"	AR3524SW45	36	15	11	10.00	AR3530SW45	40	17	11	10.50	AR3536SW45	44	18.5	11	12.60
4"	AR4024SW45	36	15	11	12.00	AR4030SW45	40	17	11	14.80	AR4036SW45	44	18.5	11	15.00
5"						AR5030SW45	40	17	11	19.00	AR5036SW45	44	18.5	11	21.60
6"											AR6036SW45	44	18.5	12	43.50

### 48" - 60"

		Radius									
A	48 Inch					60 Inch					
Size	Item No	B	C	T	Wt.	Item No	B	C	T	Wt.	
1"	AR1048SW45	54.5	22.5	12	3.00	AR1060SW45	62	26	12	3.40	
1¼"	AR1248SW45	54.5	22.5	12	4.00	AR1260SW45	62	26	12	4.60	
1½"	AR1548SW45	54.5	22.5	12	5.00	AR1560SW45	62	26	12	5.70	
2"	AR2048SW45	54.5	22.5	12	6.50	AR2060SW45	62	26	12	7.40	
2½"	AR2548SW45	54.5	22.5	12	10.40	AR2560SW45	62	26	12	11.90	
3"	AR3048SW45	54.5	22.5	12	14.00	AR3060SW45	62	26	12	16.00	
3½"	AR3548SW45	54.5	22.5	12	16.00	AR3560SW45	62	26	12	18.30	
4"	AR4048SW45	54.5	22.5	12	19.00	AR4060SW45	62	26	12	21.80	
5"	AR5048SW45	54.5	22.5	12	26.00	AR5060SW45	62	26	12	29.80	
6"	AR6048SW45	54.5	22.5	12	33.50	AR6060SW45	62	26	12	38.40	

Dimensional data is for reference only

NPT thread with end-cap on each end

Aluminum Rigid Sweeps meet UL6 and ANSI C80.5

## ADDITIONAL RESOURCES

### VISIT CALCONDUIT.COM:

- Quick and easy access to online catalog and brochures
- Educational resources and latest news
- Product videos
- Submittal sheets
- Price guide
- Rep locator
- Mobile friendly

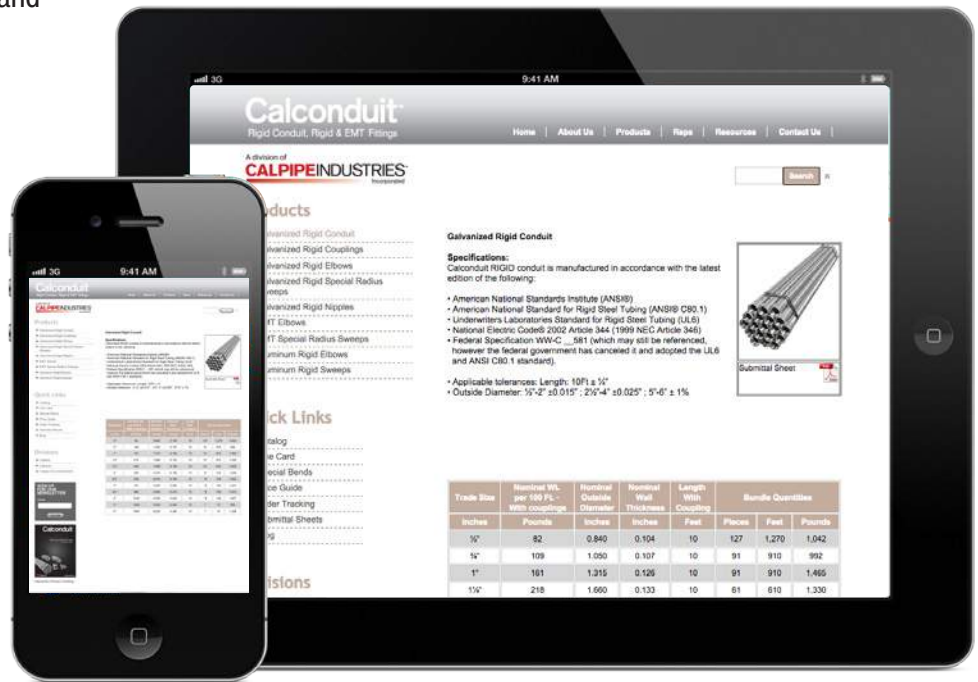

## ENVIRONMENTAL SUSTAINABILITY THE CALPIPE COMMITMENT

- Steel is the most recycled material in North America
- One ton of recycled steel saves 2,500 pounds of iron ore, 1,400 pounds of coal and 120 pounds of limestone
- In addition to manufacturing a fully recyclable product, Calconduit is committed to minimizing their carbon footprint by constantly implementing new environmentally sustainable practices



Source: Steel Recycling Institute



## Rigid Conduit, Rigid & EMT Fittings

### GALVANIZED RIGID ELBOWS



**Diameters:** 1/2" to 6"  
**Specifications:** UL 6 & cUL 6, ANSI C80.1  
**Degrees of bend:**  
 90°, 60°, 45°, 30°, 22-1/2°, 15°, 11-1/4°



### GALVANIZED RIGID SPECIAL RADIUS SWEEPS

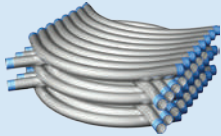

**Diameters:** 1/2" to 6"  
**Specifications:** UL 6 & cUL 6, ANSI C80.1  
**Degrees of bend:**  
 90°, 60°, 45°, 30°, 22-1/2°, 15°, 11-1/4°

**Radii available:**  
 12", 18", 24", 30", 36", 42", 48", 60"



### GALVANIZED RIGID COUPLINGS



**Diameters:** 1/2" to 6"

### GALVANIZED RIGID NIPPLES



**Diameters:** 1/2" to 6" by any length  
**Specifications:** UL 6 & cUL 6, ANSI C80.1



### OFFSETS, KICKS & RISERS



**Diameters:** 1/2" to 6"  
 GRC, EMT & PVC Coated

\*See other side for information on custom bending capabilities



### GALVANIZED RIGID CONDUIT

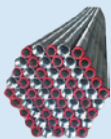

**Diameters:** 1/2" to 6"  
**Specifications:** UL 6 & cUL 6, ANSI C80.1  
 10' Lengths standard

\*Special lengths through 20' available by request



### EMT ELBOWS AND SPECIAL RADIUS SWEEPS



**Diameters:** 1/2" to 4"  
**Specifications:** UL 797 & cUL 797, ANSI C80.3  
**Degrees of bend:**  
 90°, 60°, 45°, 30°, 22-1/2°, 15°, 11-1/4°



## GOOD SERVICE IS GOOD BUSINESS

### Calconduit™

Rigid Conduit, Rigid & EMT Fittings  
 A division of  
**CALPIPE INDUSTRIES**  
Incorporated

Calconduit's superior customer service impacts the buying process from specification to shipment. With an experienced service department and skilled work force, no bend requirement is too "special." Committed to being a true problem solver, we accommodate requests and those "unscheduled" changes to conduit runs that are impossible to produce using field equipment.

The **Calconduit Difference** comes from our:

- Competitive pricing
- Custom bending capabilities
- Fast, reliable and responsive team
- Made in US & ARRA capabilities 

Calconduit specializes in the following custom bends in diameters from 1/2" thru 6":

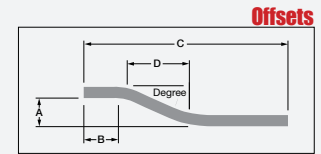

#### Special Radius Sweeps

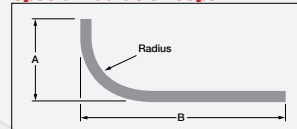

#### Kicks

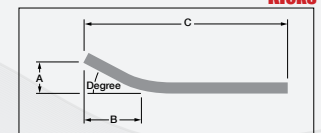

#### Saddles

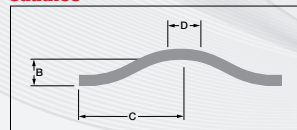

Calconduit.com

(800) CALPIPE

### Calconduit™

Rigid Conduit, Rigid & EMT Fittings  
 a division of  
**CALPIPE INDUSTRIES**  
Incorporated

The Trusted Source for Standard or Custom Conduit Requirements

90° bend

**A**

**B**

**SPECIAL BENDS**

- SPECIAL RADIUS SWEEPS
- OFFSETS
- KICKS
- SADDLES

New Expanded Rep Coverage across the USA and Canada

Calconduit.com

(800) Calpipe

NOTES

A division of

**CALPIPE INDUSTRIES™**  
Incorporated

- PROVIDING SPECIAL RADIUS SWEEPS AND CUSTOM BENDS FOR NEARLY THREE DECADES
- INDUSTRY LEADING 24-72 HOUR TURNAROUND ON MOST PRODUCTION RUNS AND SPECIALS
  - QUICK RESPONSE TO PROJECT REQUIREMENTS NATIONWIDE
  - STOCKING LOCATIONS THROUGHOUT THE USA
  - UNPARALLELED BENDING EXPERTISE

# Calconduit™

Rigid Conduit, Rigid, EMT & AL Fittings

Keep America Working



**CALPIPE INDUSTRIES, INC.**  
19440 S. Dominguez Hills Dr.  
Rancho Dominguez, CA 90220  
(800) Calpipe  
(562) 803-4388

**CALCONDUIT SALES  
SUPPORT & DISTRIBUTION  
CENTER**  
19440 S. Dominguez Hills Dr.  
Rancho Dominguez, CA 90220  
(800) Calpipe  
(562) 803-4388

**MIDWEST  
DISTRIBUTION CENTER**  
6451 Northwinds Pkwy  
Hobart, IN 46342  
(219) 844-6800  
(800) 536-2248  
(219) 844-6884 fax

FOR SALES INQUIRIES CALL (800) 536-2248

2016 CAT-RevB