

75 WATT WDE SERIES PMBus™ DC/DC CONVERTERS



Features

- 'Black Box' digital fault datalogging
- Digitally Configurable voltage, current & over-temperature
- Digitally configurable fault response
- Real-time performance data via PMBus™ serial interface
- High power density
- 4:1 Input voltage range
- Small size 2.5" x 1.1" x 0.50"
- Efficiency up to 90%
- Excellent thermal performance with metal case
- Auto-softstart
- Constant frequency
- Remote sense
- Remote ON/OFF
- Analog and digital voltage trim
- No minimum load requirement
- Water washable, high humidity applications
- Good shock and vibration damping
- Available in both RoHS and non-RoHS construction. See ordering info below.

Description

The 4:1 Input Voltage 75 Watt Single WDE DC/DC converter provides a precisely regulated dc output. The output voltage is fully isolated from the input, allowing the output to be positive or negative polarity and with various ground connections. The 75 Watt WDE meets the most rigorous performance standards in an industry standard footprint for mobile (12VIN), process control (24VIN), military COTS (28VIN) and higher VIN applications.

The 4:1 Input Voltage 75 Watt WDE includes remote sensing, ultra-wide output voltage trim, and remote ON/OFF. The digital power management features via the industry standard PMBus™ enable increased reliability, configurability, voltage / current precision and fault management, including:

- Precision, adjustable over-temperature protection
- Configurable input under and over voltage protection
- Configurable current-limit inception and shut-down delay
- Logging of historical fault events in non-volatile memory
- Precision (+/-0.2%) output voltage accuracy and trim
- Monitoring of VIN, VOUT, IOUT and Temperature
- Digital dynamic adjustment of VOUT
- Digital warning thresholds for faults

Model	Input Range VDC		Vout VDC	Iout ADC
	Min	Max		
24S5.15WDE	9	36	5.0	15
24S12.6WDE	9	36	12	6
24S24.3WDE	9	36	24	3
24S28.3WDE	9	36	28	2.5
24S48.1WDE	9	36	48	1.5
48S24.3WDE	18	75	24	3
48S28.3WDE	18	75	28	2.5
48S48.1WDE	18	75	48	1.5

To order RoHS, add (RoHS) to the part number



75 WATT WDE SERIES PMBus™ DC/DC CONVERTERS



24V Input Parameters			
Model	24SXX-YY-WDE		Units
Voltage Range	MIN TYP MAX	9.0 24.0 36.0	V
Input Overvoltage (100 ms)	MAX	50 [Unit may shut down at input overvoltage set point]	V
Input Ripple Rejection (120Hz)	TYP	20 [With recommended ext. LC filter]	dB
Undervoltage Lockout	TYP	Start-up: 9.0 / Shut-down: 8.75	V
Input Reverse Voltage Protection	Yes - Main FET Body Diode Conduction 2A max/1Sec		
Inrush Current	MAX	0.05 [With recommended ext. LC filter]	A ² s
Reflected Ripple	TYP	50 [With recommended ext. LC filter]	mA _{RMS}
Switching Frequency	TYP	275	kHz
Recommended Fuse	See Note 2		A
External Input Capacitance	MIN	30 (Ceramic)	μF

24V Output Parameters							
Model		24S5.15WDE	24S12.6WDE	24S24.3WDE	24S28.3WDE	24S48.1WDE	Units
Output Voltage		5.0	12	24	28	48	V
Output Voltage Setpoint Accuracy	MAX	0.2					%
Turn On Overshoot	TYP	5					%
Temperature Coefficient (5)	TYP MAX	0.02					%/°C
Noise (3)	TYP TYP	50 25	120 50	240 80	280 100	480 150	mV _{P-P} mV _{RMS}
Load Current	MIN MAX	0 15	0 6	0 3	0 2.5	0 1.5	A
Load Transient Overshoot (4)	TYP	5					%
Load Transient Recovery Time (4)	TYP	500					μs
Load Regulation (6) Min-Max Load	TYP MAX	0.2 1					%
Line Regulation Vin = Min-Max	TYP MAX	0.2 1					%
Overvoltage Protection (OVP) Threshold OVP Type - Non-latching Open Loop Overvoltage Clamp Hiccup Mode	TYP	120					%
Output Current Limit Vout = 90% of Vout-nom	TYP	120					%
External Output Capacitance	MIN MAX	300 3000	20 1000	20 400	20 300	20 200	μF
Efficiency - Max Load	TYP	91	92	87	89	88	%

75 WATT WDE SERIES PMBus™ DC/DC CONVERTERS



48V Input Parameters			
Model		48SXX-YY-WDE	Units
Voltage Range	MIN TYP MAX	18.0 48.0 75.0	V
Input Overvoltage (100 ms)	MAX	100 [Unit may shut down at input overvoltage set point]	V
Input Ripple Rejection (120Hz)	TYP	20 [With recommended ext. LC filter]	dB
Undervoltage Lockout	TYP	Start-up: 17.8 / Shut-down: 17.5	V
Input Reverse Voltage Protection		Yes - [Main FET Body Conduction 2.5A / 1Sec Max]	
Inrush Current	MAX	0.1 [With recommended ext. LC filter]	A ² s
Reflected Ripple	TYP	50 [With recommended ext. LC filter]	mA _{RMS}
Switching Frequency	TYP	275	kHz
Recommended Fuse		See Note 2	A
External Input Capacitance	MIN	20 (Ceramic)	μF

48V Output Parameters					
Model		48S24.3WDE	48S28.3WDE	48S48.1WDE	Units
Output Voltage		24	28	48	V
Output Voltage Setpoint Accuracy	MAX	0.2			%
Turn On Overshoot	TYP	5			%
Temperature Coefficient (5)	TYP MAX	0.02			%/°C
Noise (3)	TYP TYP	240 80	280 100	480 150	mV _{P-P} mV _{RMS}
Load Current	MIN MAX	0 3	0 2.5	0 1.5	A
Load Transient Overshoot (4)	TYP	5			%
Load Transient Recovery Time (4)	TYP	500			μs
Load Regulation (6) Min-Max Load	TYP MAX	0.2 1			%
Line Regulation Vin = Min-Max	TYP MAX	0.2 1			%
Overvoltage Protection (OVP) Threshold OVP Type - Non-latching Open Loop Overvoltage Clamp	TYP	120			%
Output Current Limit Vout = 90% of Vout-nom	TYP	120			%
External Output Capacitance	MIN MAX	20 400	20 300	20 200	μF
Efficiency - Max Load	TYP	87	89	89	%

75 WATT WDE SERIES PMBus™ DC/DC CONVERTERS



General Specifications			
All Models			Units
ON/OFF Function			
Converter - ON HIGH Logic Level / Leave ON/OFF Pin Open (11)	MIN	3.0	V
External Leakage Current Allowed for Logic High (7)	MAX	10	µA
Converter - OFF LOW Logic Level / Tie ON/OFF Pin to -INPUT (11)	MAX	1.0	V
Sinking Current for Logic Low	MAX	500	µA
Idle Current (Module is OFF)	TYP	40	mA
Turn-on Time to 1% error	TYP	40	ms
Output Voltage Remote Sensing (13)			
Maximum Voltage Drops on Leads	MAX	750	mV
Line Regulation under remote sensing	TYP MAX	0.2 1	%
Load Regulation under remote sensing	TYP MAX	0.2 1	%
Output Voltage Trim (13)			
Trim Range	MIN TYP	-20 +10	% of Vout
Input Resistance	TYP	47.5	kΩ
Open Circuit Voltage	TYP	2.0	V
Trim Limit			
Maximum Output Voltage	TYP	110	% of Vout
Isolation			
Input to Output Isolation 10µA Leakage	MAX	1544	VDC
Input to Output Resistance	MIN	10	MΩ
Input to Output Capacitance	TYP	3300	pF
Environmental			
MTBF Telcordia (Bellcore) standard SR-332, issue 2, using Method 1.	10.9 Million		hours
Case Operating Temperature Range	MIN MAX	-55 +100	°C
Storage Temperature	MIN MAX	-55 +120	°C
Thermal Impedance (8)	TYP	9	°C/W
Thermal Shutdown Internal Temperature (Auto Restart)	TYP	110	°C
General			
Unit Weight	55		g
Case Dimension	2.5" x 1.1" x 0.50"		
Designed to meet UL/cUL 60950, IEC/EN 60950-1			

Notes:

- All parameters measured at Tc=+25°C ambient, Vin = Vnom, maximum rated load, unless otherwise noted. Refer to CALEX Application Notes for definition of terms, measurement circuits and other information.
- External fusing should be used for system protection in the event of a catastrophic failure. See CALEX Application Note 9 in the Calex DC/DC Catalog to determine the correct fuse.
- Output noise is measured with a 10µF ceramic capacitor and a 1µF ceramic capacitor connected across the output pins. The fundamental component of noise is at the switching frequency. Using smaller value capacitors will make the output noise slightly higher. Bandwidth limit is 20 MHz. In system board design high-voltage capacitors between input and output from 1000pF to 6800pF can be used to reduce common-mode noise.
- Load Transient Overshoot is the output voltage peak amplitude, referenced to the final value, due to a step load change from 50% of maximum load to 75% of maximum load. "Load Transient Overshoot" and "Dynamic Response" are the same specification. Load Transient Recovery Time is the time it takes the output to return to the specified voltage error band centered around the final value. Transient response may degrade at low load currents.
- Temperature coefficient is defined for case temperatures. Output voltage deviation is calculated as the maximum resulting from either 1) 25°C case to maximum operating case temperature, or 2) 25°C case to minimum operating case temperature.
- Load regulation is defined as the output voltage change resulting from a load current change from minimum to maximum. The voltage is measured at the output pins.
- When an external ON/OFF switch is used, such as an open collector switch, logic high requires the switch to be high-impedance. Switch leakage currents greater than 10µA may be sufficient to trigger the ON/OFF to the logic-low state.
- Thermal impedance is tested with the converter mounted vertically and facing another printed circuit board 1/2 inch away. Thermal impedance is approximately 9°C/W.
- Water washability - Calex DC/DC converters are designed to withstand most solder/wash processes. Careful attention should be used when assessing the applicability in your specific manufacturing process. Converters are not hermetically sealed.
- The input impedance on these units must be kept to a maximum of 100mΩ. In order to support this requirement, this converter needs 55µF of capacitance (low ESR) for every 1.0µH of inductance between the power source and the DC/DC converter.
- The range between 1V as maximum turn off voltage and 3V as minimum turn on voltage is considered the dead-band. Operation in the dead-band is not recommended.
- MTBF is calculated based on MIL-HDBK-217F under the following conditions:
Reliability prediction method = Part Stress Analysis
Baseplate temperature = 40°C
Environment = Ground, Benign
- Refer to Calex Application Note 4 for methods to apply Remote Sense and Trim.
- Specifications subject to change without notice.
- RoHS Compliance:
See Calex Website www.calex.com/RoHS.html for the complete RoHS Compliance statement.
The RoHS marking is as follows.



75 WATT WDE SERIES PMBus™ DC/DC CONVERTERS



Characteristic Curves:

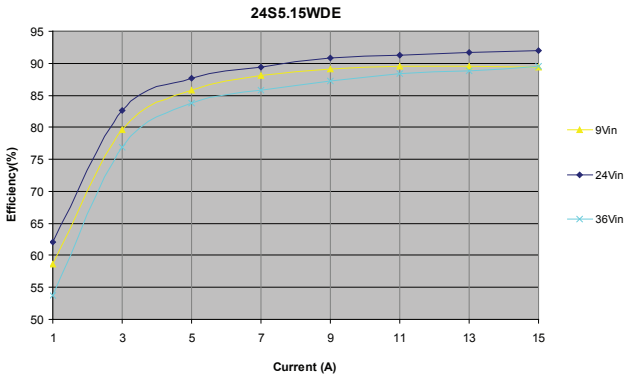

24S5.15WDE Efficiency Curve

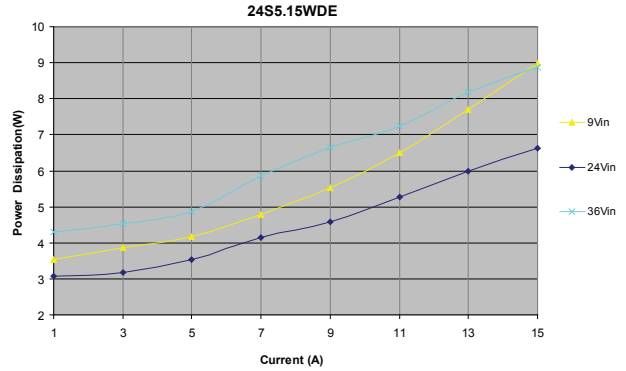

24S5.15WDE Power Dissipation

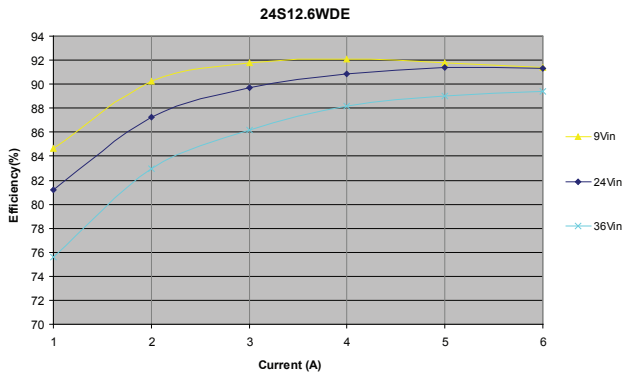

24S12.6WDE Efficiency Curve

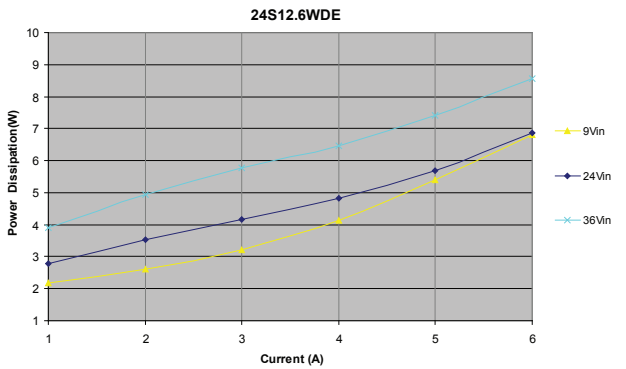

24S12.6WDE Power Dissipation

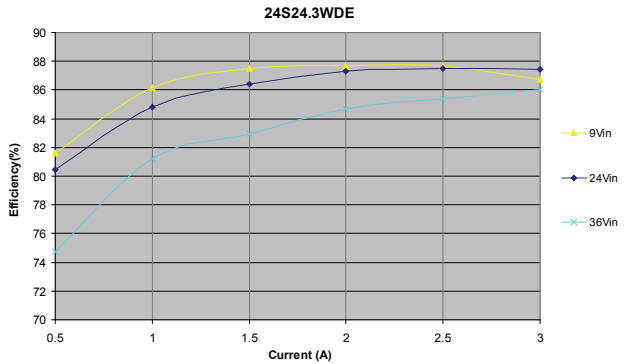

24S24.3WDE Efficiency Curve

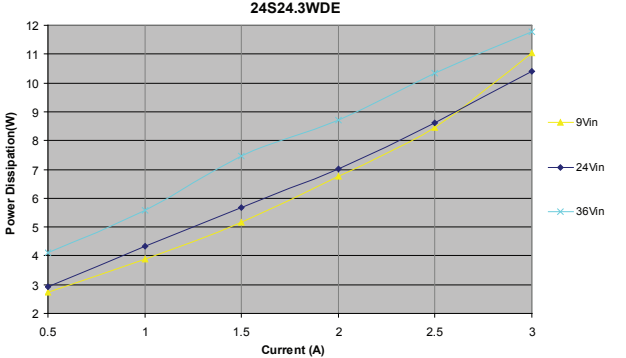

24S24.3WDE Power Dissipation

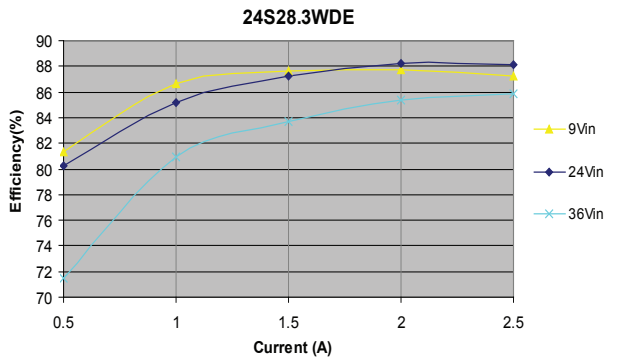

24S28.3WDE Efficiency Curve

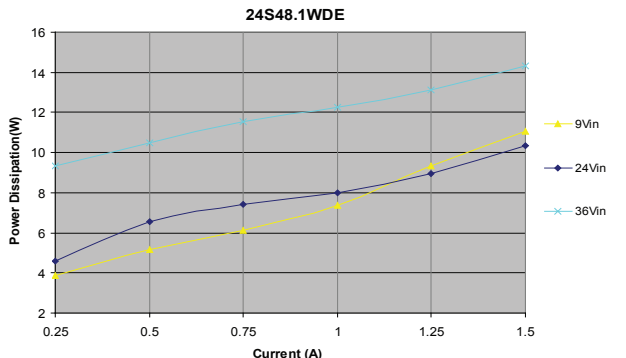

24S28.3WDE Power Dissipation



75 WATT WDE SERIES PMBus™ DC/DC CONVERTERS

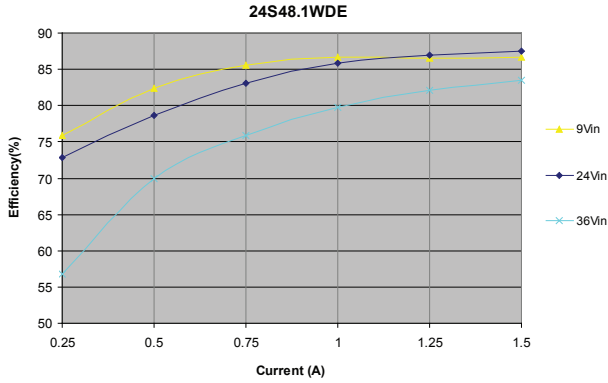

24S48.1WDE Efficiency Curve

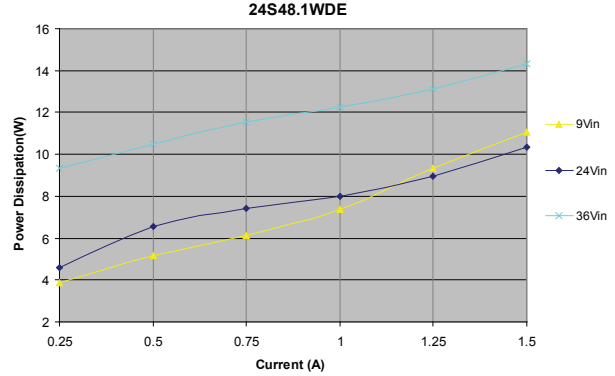

24S48.1WDE Power Dissipation

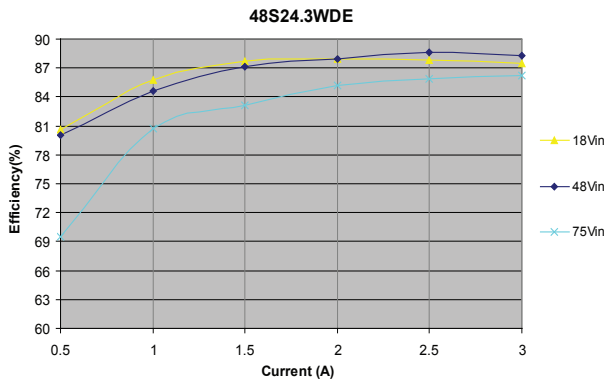

48S24.3WDE Efficiency Curve

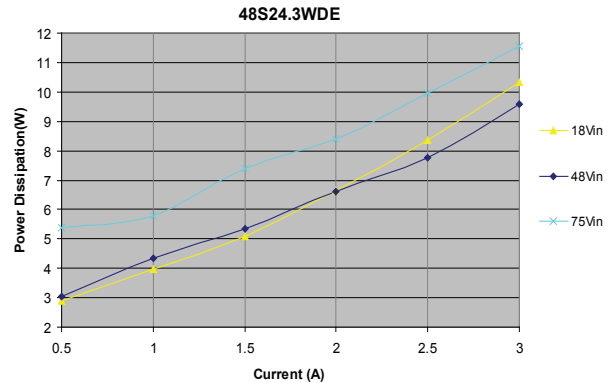

48S24.3WDE Power Dissipation

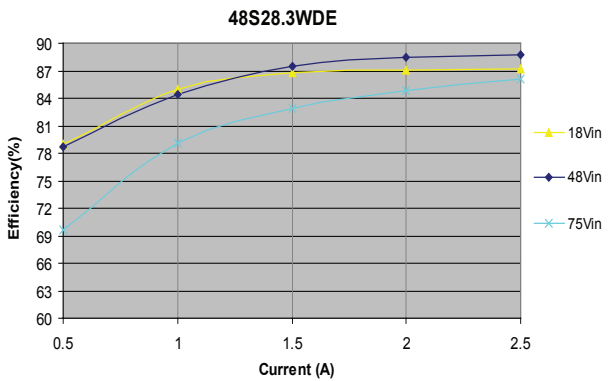

48S28.3WDE Efficiency Curve

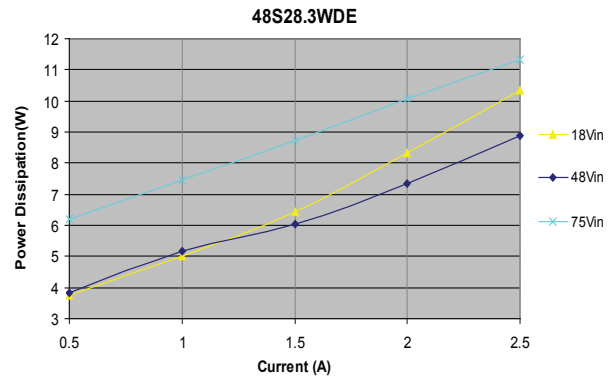

48S28.3WDE Power Dissipation

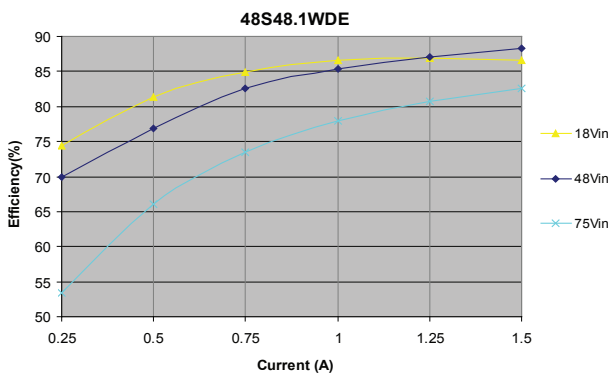

48S48.1WDE Efficiency Curve

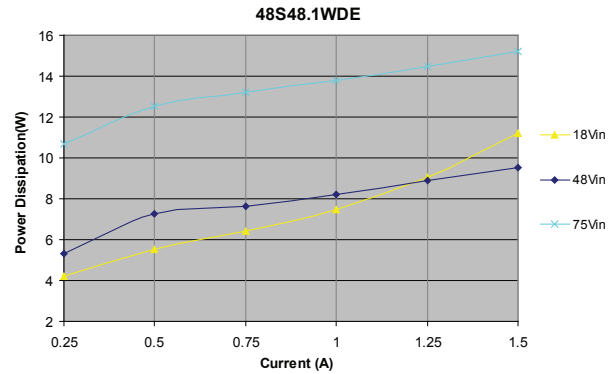

48S48.1WDE Power Dissipation



75 WATT WDE SERIES PMBus™ DC/DC CONVERTERS

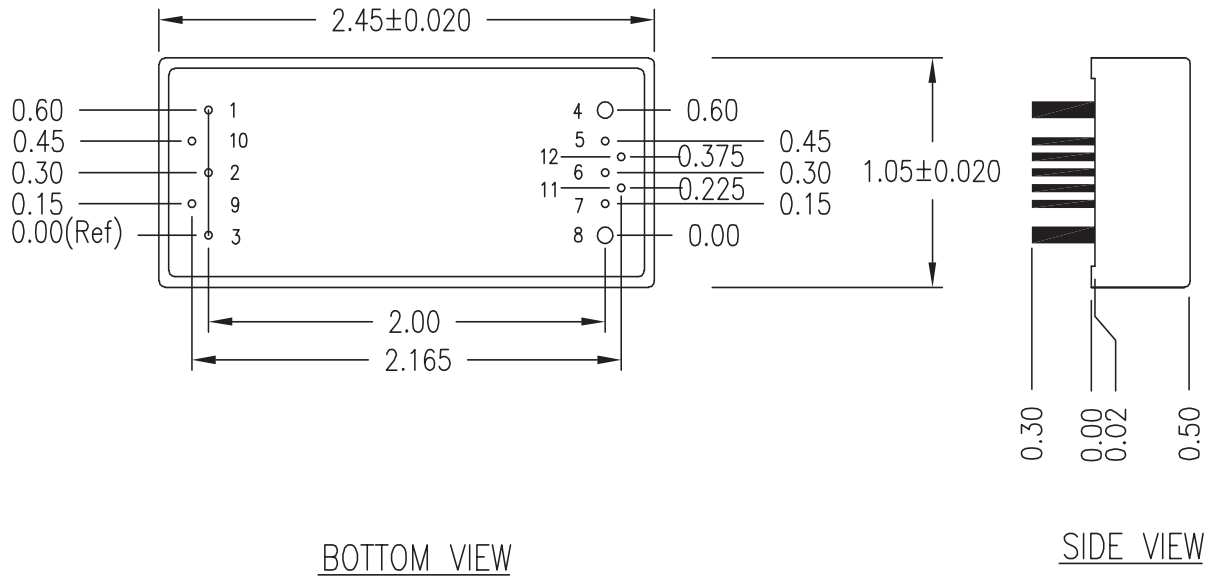

Pin	Name	Pin Dia. (Typ.)
1	-Input	0.04"
2	On/Off	0.04"
3	+Input	0.04"
4	-Output	0.06"
5	-Sense	0.04"
6	Trim	0.04"
7	+ Sense	0.04"
8	+Output	0.06"
9	PMBus™ SDA (-Input Ref.)	0.04"
10	PMBus™ SCL (-Input Ref.)	0.04"
11	PMBus™ SCL (-Output Ref.)	0.04"
12	PMBus™ SDA (-Output Ref.)	0.04"

TOLERANCE: ALL DIMENSIONS ARE TYPICAL IN INCHES UNLESS OTHERWISE NOTED:	
X.XX	±0.02
X.XXX	±0.005

75 WATT WDE SERIES PMBus™ DC/DC CONVERTERS



External Input Filter Recommendation

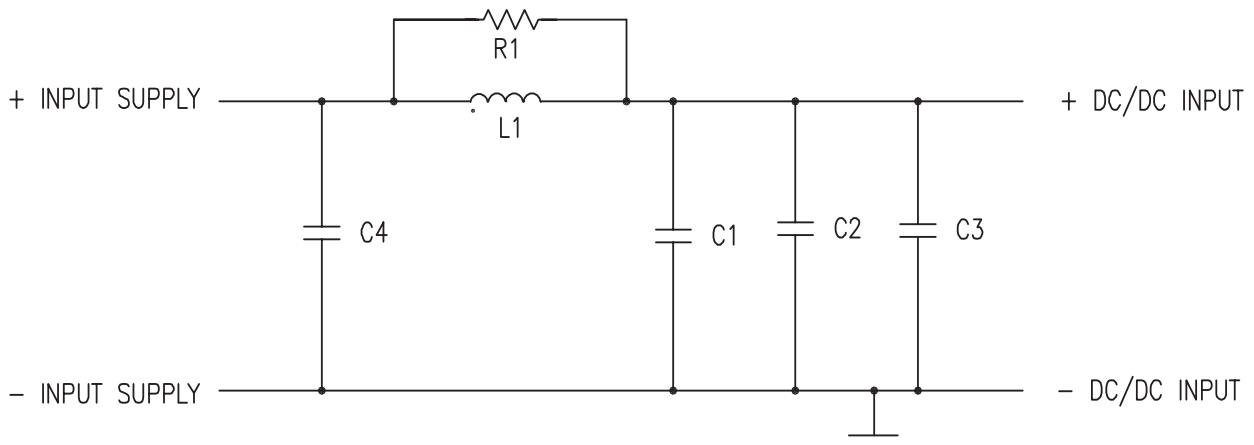

Note: Capacitors C1, C2 and C3 to be placed within 0.5" of DC/DC input pins.

9 - 36Volt Input Range

Reference	Description	Part Number	Supplier
R1	1 Ω , 0.25W	Any	Any
L1	470 nH, 10.9A	FP3-R47-R or Equivalent	Cooper-Bussman
C1, C2, C3	10 μ F, 50V, X5R, 1206	CGA5L3X5R1H106K or Equivalent	TDK
C4	100 μ F, 63V, 105C, Electrolytic	UPM1J101MPD-ND or Equivalent	Nichicon

18 - 75Volt Input Range

Reference	Description	Part Number	Supplier
R1	2.2 Ω , 0.25W	Any	Any
L1	1 μ H, 6.2A	FP3-1R0-R or Equivalent	Cooper-Bussman
C1, C2, C3	4.7 μ F, 100V, X7S, 1210	C3225X7S2A475M or Equivalent	TDK
C4	47 μ F, 100V, 105C, Electrolytic	UPW2A470MPD or Equivalent	Nichicon

Note: Use only ceramic capacitors in positions C1, C2 and C3.