



MS8 Mounting Kit

Description

The MS8 mounting kit will accept a 1" x 2", 1.6" x 2" or 2" x 2" DC/DC converter. Screw terminals allow for easy use in a chassis mounted application. The MS8 may also be used as a test and evaluation board.

The mounting kit includes a barrier strip for easy wire attachment and an input fuse. Provisions are made for the user to add capacitors to the output for noise reduction. If output capacitors are used consult the data sheets for the specific converter to select capacitors. The MS8 also has an optional input capacitor for converters which require an external input capacitor.

A trimpot for adjusting the output is included for all single and dual models which have a trim pin. The trimpot has no effect on units with out a trim pin. The trimpot may be removed if trimming is not desired.

Due to the large number of units that the MS8 supports, it may be required to change the fuse for your specific application. See CALEX application notes for selecting the correct fuse size.

Although the MS8 comes with solderless sockets for mounting the converter, it is recommended that the converter be soldered to the mounting kit for improved connection reliability under severe environmental or vibration conditions.

The MS8 may be conveniently attached to a chassis by using the 4 X 0.156 inch mounting holes located at all four corners of the board.

MS8 Mounting Kit Models	
Model	Description
MS8-S1.5	Single with 1.5 Amp Fuse
MS8-S4	Single with 4 Amp Fuse
*MS8-S6	Single with 6 Amp Fuse
MS8-CS1.5	Single with 1.5 Amp Fuse and 180µF, 100V Input Cap
MS8-CS4	Single with 4 Amp Fuse and 180µF, 100V Input Cap
*MS8-CS6	Single with 6 Amp Fuse 180µF, 100V Input Cap
MS8-D1.5	Dual with 1.5 Amp Fuse
MS8-D4	Dual with 4 Amp Fuse
MS8-CD1.5	Dual with 1.5 Amp Fuse and 180µF, 100V Input Cap
MS8-CD4	Dual with 4 Amp Fuse and 180µF, 100V Input Cap
MS8-T1.5	Triple with 1.5 Amp Fuse
MS8-T4	Triple with 4 Amp Fuse
MS8-CT1.5	Triple with 1.5 Amp Fuse and 180µF, 100V Input Cap
MS8-CT4	Triple with 4 Amp Fuse and 180µF, 100V Input Cap

* MS8-S6 & MS8-CS6 are for 9 - 36 Vin MHW.

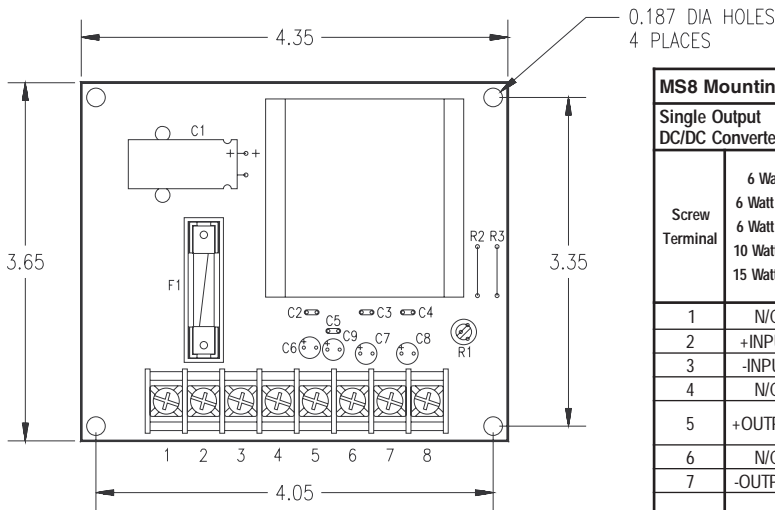

MS8 Mounting Kit		
Single Output DC/DC Converters		
Screw Terminal	6 Watt	12 Watt LV 15 Watt TC 20 Watt NT 30 Watt NT 30 Watt MH/MHW *
1	N/C	ON/OFF
2	+INPUT	+INPUT
3	-INPUT	-INPUT
4	N/C	N/C
5	+OUTPUT	N/C
6	N/C	+OUTPUT
7	-OUTPUT	-OUTPUT
8	N/C	TRIM

MS8 Mounting Kit		
Dual Output DC/DC Converters		
Screw Terminal	10 Watt "Low Input" WD 10 Watt WD	12 Watt LV 15 Watt TC 20 Watt NT
1	N/C	ON/OFF
2	+INPUT	+INPUT
3	-INPUT	-INPUT
4	N/C	N/C
5	+OUTPUT	+OUTPUT
6	CMN	CMN
7	-OUTPUT	-OUTPUT
8	N/C	TRIM

MS8 Mounting Kit	
Triple Output DC/DC Converters	
Screw Terminal	20 Watt HP
1	ON/OFF
2	+ INPUT
3	- INPUT
4	N/C
5	+12/15 OUTPUT
6	+5 OUTPUT
7	CMN
8	-12/15 OUTPUT

* Contact factory for mounting kit for 9 - 36Vin MHW.

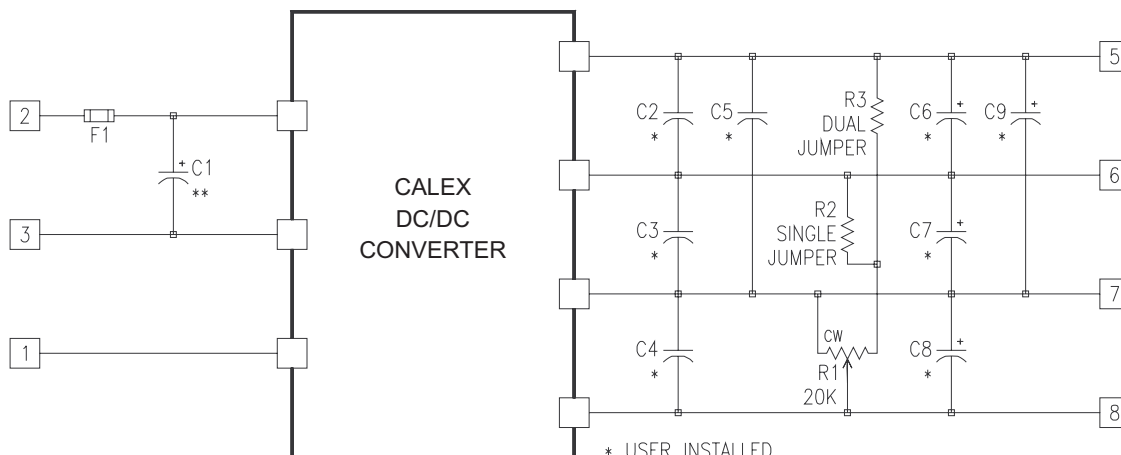

* USER INSTALLED

** ONLY USED IF EXTERNAL CAP IS REQUIRED