



NEW

Self-Clinching Self-Locking Nuts



Series CRT, CRTS, CRTA

CRT series fasteners provide a low-installed-cost solution where a clinching fastener with repeat locking torque is required. The design allows for greater reusability and minimizes the possibility of thread damage of the mating screw.

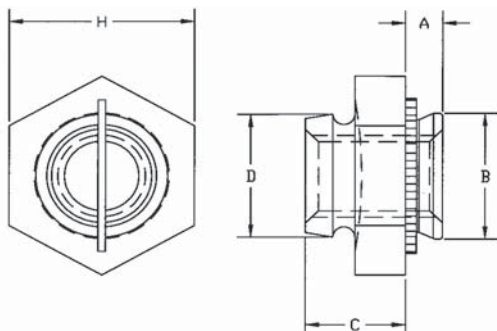

Series	Material	Finish
CRT	Carbon Steel	Black Dry film Lubricant over Zinc Phosphate
CRTS	300 Series Stainless Steel	Black Dry film Lubricant
CRTA	7075-T6 Aluminum	None

Thread: Internal 3B, ANSI B1.1 (6H ANSI/ASME B1.13M).
Use in: Cold-rolled Steel.

Part Number Structure:
CRTS 440-1ML



Note: Thread locking performance for CRT & CRTS is equivalent to applicable NASM25027 specifications.

Dimensions & Specifications

INCH (in.)	Thread Size	Series			Shank Code	A Max.	Min.	+.003 -.000	B Max.	D Max.	C ±.010	H Nom.	Min.
		Carbon Steel	Stainless Steel	Aluminum [†]									
	#440	CRT	CRTS	CRTA	1	.038	.040	.187	.186	.185	.135	.250	.156
					2	.054	.056						
	#6-32	CRT	CRTS	CRTA	1	.038	.040	.219	.218	.220	.145	.312	.187
					2	.054	.056						
	#8-32	CRT	CRTS	CRTA	1	.038	.040	.266	.265	.250	.175	.343	.203
					2	.054	.056						
#10-32	CRT	CRTS	CRTA	1	.038	.040	.312	.311	.285	.205	.375	.218	
				2	.054	.056							

Dimensions & Specifications

METRIC (mm)	Thread Size	Series			Shank Code	A Max.	Min.	+.08 -.00	B Max.	D Max.	C ±.25	H Nom.	Min.
		Carbon Steel	Stainless Steel	Aluminum [†]									
	M3 x 0.5	CRT	CRTS	CRTA	1	.97	1.0	4.75	4.73	4.85	3.43	6.35	4
					2	1.38	1.4						
	M4 x 0.7	CRT	CRTS	CRTA	1	.97	1.0	6.76	6.73	6.2	4.45	8.73	5.2
					2	1.38	1.4						
	M5 x 0.8	CRT	CRTS	CRTA	1	.97	1.0	7.92	7.9	7.4	5.21	9.53	5.6
					2	1.38	1.4						

[†]Not stocked, available on special order. *Lubricated screw is required.

Continued on next page.







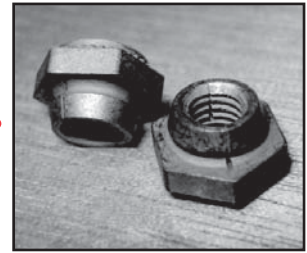

Self-Clinching Self-Locking Nuts

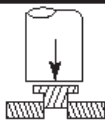
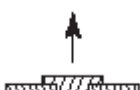
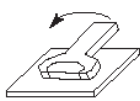
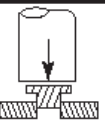
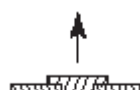
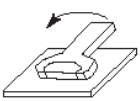
Series CRT, CRTS & CRTA

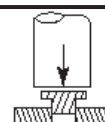

Continued from previous page.

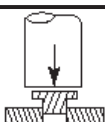
Installation & Performance Data									
INCH (in.)		Thread Size	Shank Code	Cold-rolled Steel			5052-H34 Aluminum		
									
				Installation Force (lbs.)	Pushout (lbs.)	Torque-out (in.-lbs.)	Installation Force (lbs.)	Pushout (lbs.)	Torque-out (in.-lbs.)
#4-40			1	3000	155	31	1600	134	26
			2	3000	258	41	2000	207	36
#6-32			1	4000	155	46	2400	134	26
			2	4300	284	51	2700	232	46
#8-32			1	4000	196	51	2700	155	46
			2	4300	310	72	3000	258	52
#10-32			1	4000	258	103	3200	155	93
			2	4300	310	124	3200	258	108

Installation & Performance Data									
METRIC (mm)		Thread Size	Shank Code	Cold-rolled Steel			5052-H34 Aluminum		
									
				Installation Force (kN)	Pushout (N)	Torque-out (N•m)	Installation Force (kN)	Pushout (N)	Torque-out (N•m)
M3			1	13.5	688	3.5	7	598	2.9
			2	13.5	1148	4.6	9	921	4.0
M4			1	18	874	5.8	12	688	5.1
			2	18	1376	8.1	12	1148	5.8
M5			1	18	1148	11.6	12	688	10.4
			2	19	1376	14.0	12	1148	12.2