



# Collar Base

## Self-Clinching Panel Fasteners

### Series PSK/PSS



PS panel fasteners are preassembled for attachment to removable sheet metal panels. Captive screw assemblies are spring loaded, for servicing ease, and provide low profile when secure. Combination cross-recess/slot head with knurled or smooth knob allows finger or tool operation. The base design has a collar that provides a mechanical stop when installed.

Series	Head	Material	Finish*
PSK	Knurled	Aluminum Knob	Natural
		Steel Base	Nickel/Copper ASTM B689
PSS	Smooth	Stainless Screw	Passivated ASTM A967

\*Black Nitride (BN) finish available.

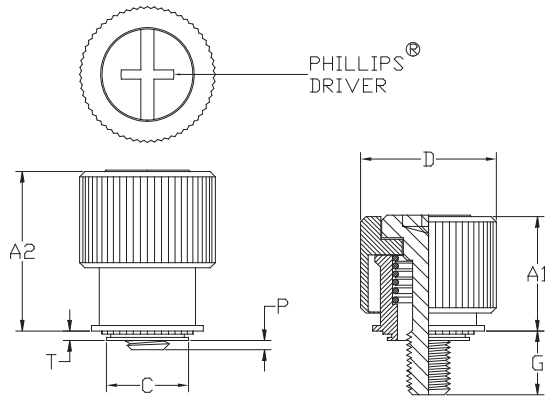

Thread: External 2A, ANSI B1.1 (6g ANSI/ASME B1.13M).  
Use in: Materials with Rockwell Hardness of B-80 or less.

Part Number Structure:

PSK-440-0



### Dimensions & Specifications

Thread Size	Driver Size	Type		Thread Code	Screw Length Code	Min.	T Max.	P ±.025	G ±.025	C Max.	D ±.010	A1 Nom.	A2 Nom.	+ .003 - .000	Min.		
		Knurled Head	Smooth Head														
#4-40	#1	PSK	PSS	440	-0	.036	.036	.000	.170	.218	.417	.310	.450	.219	.28		
					-1											.060	.230
					-2											.120	.290
#6-32	#2	PSK	PSS	632	-0	.036	.036	.000	.230	.249	.450	.450	.640	.250	.29		
					-1											.060	.290
					-2											.120	.350
#8-32	#2	PSK	PSS	832	-0	.036	.036	.000	.230	.311	.514	.450	.640	.312	.33		
					-1											.060	.290
					-2											.120	.350
#10-32	#2	PSK	PSS	1032	-0	.036	.036	.000	.230	.311	.514	.450	.640	.312	.33		
					-1											.060	.290
					-2											.120	.350
1/4-20	#3	PSK	PSS	420	-0	.036	.036	.000	.290	.374	.575	.530	.790	.375	.46		
					-1											.060	.350
					-2											.120	.410



# Collar Base Self-Clinching Panel Fasteners

## Series PSK/PSS

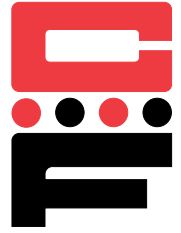

### Dimensions & Specifications

Thread Size	Driver Size	Type		Thread Code	Screw Length Code	Min.	T Max.	P ±.64	G ±.64	C Max.	D ±.25	A1 Nom.	A2 Nom.	+08 -00	Min.
		Knurled Head	Smooth Head												
M3x0.5	#1	PSK	PSS	M3	-0	.92	.92	0	4.32	5.54	10.59	7.87	11.43	5.56	7.11
					-1			1.52	5.84						
					-2			3.05	7.37						
M3.5x0.6	#2	PSK	PSS	M3.5	-0	.92	.92	0	5.84	6.33	11.43	11.43	16.26	6.35	7.37
					-1			1.52	7.37						
					-2			3.05	8.89						
M4x0.7	#2	PSK	PSS	M4	-0	.92	.92	0	5.84	7.9	13.06	11.43	16.26	7.92	8.38
					-1			1.52	7.37						
					-2			3.05	8.89						
M5x0.8	#2	PSK	PSS	M5	-0	.92	.92	0	5.84	7.9	13.06	11.43	16.26	7.92	8.38
					-1			1.52	7.37						
					-2			3.05	8.89						
M6x1	#3	PSK	PSS	M6	-0	.92	.92	0	7.37	9.5	14.61	13.46	20.07	9.53	11.68
					-1			1.52	8.89						
					-2			3.05	10.41						

### Installation & Performance Data

Type	Thread Code	Sheet Material			
		Aluminum		Cold-rolled Steel	
		Installation Force (lbs.)	Pushout (lbs.)	Installation Force (lbs.)	Pushout (lbs.)
PSK PSS	440	1500	80	2500	145
	632	2000	95	3500	150
	832	3000	100	4500	160
	1032	3000	100	4500	160
	420	3500	105	5000	195
Type	Thread Code	Installation Force (kN)	Pushout (N)	Installation Force (kN)	Pushout (N)
PSK PSS	M3	6.7	355	11.1	645
	M4	13.3	445	20	710
	M5	13.3	445	20	710
	M6	15.6	465	22.2	865