

GFCI / ELCI

Circuit Protection



CATALOG

FOUNDED IN 1920



Since its founding, Carling Technologies has continually forged a tradition of leadership in quality and product innovation.

There are few products that Carling Technologies hasn't turned "ON" and fewer industries that haven't turned to Carling for solutions. With ISO and TS registered manufacturing facilities and technical sales offices worldwide, Carling ranks among the world's largest manufacturers of circuit breakers, switches, power distribution units, digital switching systems and electronic controls.



SWITCHES & CONTROLS

- Rocker
- Toggle
- Pushbutton
- Rotary

CIRCUIT PROTECTION

- Hydraulic-Magnetic
- Thermal
- GFCI / ELCI

CUSTOM SOLUTIONS

- PDU's
- Keypads
- Control Modules

MULTIPLEXED POWER SYSTEMS

- HMI Devices & I/O Modules
- Programmable Displays
- Data Communication Interfaces
- Electrical Systems Monitoring

STRATEGIC MARKETS SERVED:



On/Off Highway



Marine



Telecom/Datacom



Military



Renewable Energy

GLOBAL LOCATIONS:

Carling Technologies
World Headquarters
Plainville, CT, USA
ISO9001:2008
ISO/TS16949:2009

Maretron
Phoenix, AZ, USA

Carling Technologies
Brownsville, TX, USA
ISO14001:2004
ISO9001:2008
ISO/TS16949:2009

Carling Technologies
Matehuala, Mexico
ISO14001:2004
ISO9001:2008
ISO/TS16949:2009

Carling Technologies
Jupiter, FL, USA

Carling Technologies
European Headquarters
Exeter, UK
ISO9001:2008
ISO/TS16949:2009

Carling Technologies
Kowloon, Hong Kong
ISO9001:2008
ISO/TS16949:2009

Carling Technologies
Zhongshan, China
ISO14001:2004
ISO9001:2008
ISO/TS16949:2009

OTHER SERVED INDUSTRIES:



Medical



Industrial Control



Audio / Visual



Commercial Food



HVAC



Floor Care



Generators



Small Appliances



Security Systems



Test & Measurement

WORLDWIDE NUMBERS:



2000+
EMPLOYEES



150+
ENGINEERS



70+
DISTRIBUTORS



50+
REP FIRMS

COMPETITIVE ADVANTAGES⁺

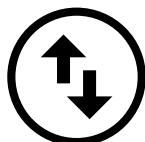

Vertical
Integration



Reliable &
On-Time Delivery



Excellent
Customer Service



Innovative &
Eco-Friendly Products

GFCI/ELCI Circuit Protection

This catalog features Carling Technologies’ current line of GFCIs/ELCIs products, which offer maximum equipment protection against overload and short circuits.

Carling’s Equipment leakage circuit breakers function as hydraulic-magnetic circuit breakers, offering customized overload and short circuit protection. In addition, they sense and guard against faults to ground using innovative electronics technologies. With the exception of small amounts of leakage, the current returning to the power supply will be equal to the current leaving the power supply. If the difference between the current leaving and returning through the earth leakage circuit breaker exceeds the leakage sensitivity setting, the breaker trips and its LED illuminates. The LED gives a clear indication that the trip occurred as a result of leakage to ground. This protection helps prevent serious equipment damage and fire.

Within This Catalog, you will find comprehensive product information for each product series including applications, specifications and ordering schemes.

Available Online are tools such as part configurator, product selectors and stock checks. Please visit www.carlingtech.com for the latest information on all our products.

Application Solution Engineers are readily available to assist you in selecting the appropriate product for your application. For further assistance, please email us at custservice@carlingtech.com

Custom Design Solutions are available for OEMs that require specific product design and performance.

Other Circuit Protection Products such as thermal protection and ground fault circuit protection are also available. Please refer to www.carlingtech.com for a complete list of product offering.

| | |
|-----------------------------|------|
| Table of Contents | Page |
| Product Selector Guide..... | 2 |

| | |
|----------------------------------|----|
| PB-Series | |
| Introduction | 3 |
| General Specifications..... | 4 |
| Ordering Scheme..... | 5 |
| Dimensional Specifications..... | 6 |
| Wiring Diagrams | 8 |
| Panel Seal Ordering Scheme | 9 |
| Panel Seal Drawings | 10 |
| Time Delays | 11 |

| | |
|----------------------------------|----|
| PC-Series | |
| Introduction | 12 |
| General Specifications..... | 14 |
| Ordering Scheme..... | 16 |
| Wiring Diagrams | 17 |
| Dimensions | 19 |
| Panel Seal Ordering Scheme | 20 |
| Panel Seal Drawings | 21 |
| Time Delay Curves..... | 22 |



PB-Series



PC-Series

| | | |
|--|---|---|
| POLES | 1-3 poles, 3rd pole switched neutral | 1-poles (1 circuit breaker + 1 GFCI sensor module), 120V, 2-pole (2 circuit breakers + 1 GFCI sensor module), 120/240V, or 120V with neutral break 2-pole (2 circuit breakers + 1 GFCI sensor module), 240VAC, 3-pole 120/240V with neutral break (sensor module has 2 pole width) |
| ACTUATOR STYLE | handle, rocker, flat rocker | handle, rocker, flat rocker, push-to-reset |
| LEAKAGE CURRENT TRIP LEVEL | 30mA & 6mA | 30mA & 6mA |
| LEAKAGE CURRENT TRIP TIME | For 30mA leakage trip: ≤ 22.2mA, shall not trip 30mA, shall trip within .10 seconds, complying with UL-1053 & ABYC E11. For 6mA leakage trip: ≤25ms | For 30mA leakage trip: ≤ 22.2mA, shall not trip 30mA, shall trip within .10 seconds, complying with UL-1053 & ABYC E11. For 6mA leakage trip: ≤25ms |
| MAX CURRENT & VOLTAGE RATINGS | 0.10-30A@120/240VAC | 0.10-50A@120/240VAC - 240VAC |
| MAX INTERRUPTING CAPACITY | 5,000A | 5,000A |
| AVAILABLE CIRCUITS | series trip | series trip |
| TERMINATION | .250" tabs, 8-32, 10-32, M4,M5 screw with upturned lugs, 8-32, 10-32, M4,M5 screw, bus type | 10-32 threaded stud |
| MOUNTING METHOD | front panel | front panel |
| OPERATING TEMPERATURE | -35° C to +65° C | -35° C to +65° C |
| APPROVALS | UL 489, UL 1077, UL 1500 | CSA Approved, UL 1053, UL 1500 |

*Manufacturer reserves the right to change product information without prior notice

PB-Series

GFCI/ELCI & PANEL SEAL

The new PB-Series, AC Residual Current Circuit Breaker with Overcurrent Protection (RCBO), combines the ground fault protection of a GFCI with the familiar overcurrent tripping characteristics of a normal circuit breaker. It utilizes the hydraulic magnetic principle which provides precise operation and performance even when exposed to extremely hot and/or cold application environments. These precision mechanisms are temperature stable and are not adversely affected by temperature changes in their operating environment. As such, derating considerations due to temperature variations are not normally required, and heat-induced nuisance tripping is avoided.



Resources:

[Download 3D CAD Files](#)

[IGS >](#) [STP >](#)

Product Highlights:

- Overload, short circuit and ground fault protection in a single package
- Handle or rocker style actuators
- Wiping Contacts - Mechanical linkage with two-step actuation - cleans contacts, provides high, positive contact pressure & longer contact life.
- A trip-free mechanism, a safety feature which makes it impossible to manually hold the contacts closed during overload or fault conditions.
- A common trip linkage between all poles, another safety feature, ensures that an overload in one pole will trip all adjacent poles.
- Front panel mounting
- Integral push-to-test button

Benefits:

- Increases safety around boats and marinas
- Protects against electrical shock hazards in areas near water
- Protects against defects in wires & conductors
- Reduces fire and shock hazards from defects in permanently installed appliances such as water heaters, battery chargers, lighting fixtures, etc.
- Detects lower level ground faults which do not trip ordinary circuit breakers, but can lead to fires, and shock hazards for boating occupants

Typical Applications:

- Marine
- Generators
- Lighting

Electrical Tables

Table A: UL Listed configurations and performance capabilities as Circuit Breakers.

| PB-SERIES TABLE A | | | | | |
|-----------------------|------------|-----------|-------|-----------------------|------------------------------|
| Circuit Configuration | Voltage | | | Current Rating (Amps) | Interrupting Capacity (Amps) |
| | Max Rating | Frequency | Phase | | |
| Series | 120 | 60 | 1 | 10 - 30 | 5000 |

Electrical

Maximum Voltage 120/240VAC 60 Hz
 Current Ratings Standard current coils: 0.100, 0.250, 0.500, 0.750, 1.00, 2.50, 5.00, 7.50, 10.0, 15.0, 20.0, 25.0 & 30.0 amps. Other ratings available, see ordering scheme.
 Insulation Resistance Minimum of 100 Megohms at 500 VDC.
 Dielectric Strength UL, CUL - 1500 V 60 Hz for one minute between all electrically isolated terminals. PB-Series circuit breakers comply with the 8mm spacing and 3750V 60 Hz dielectric requirements from hazardous voltage to operator accessible surfaces and between adjacent poles
 Impedance Values from Line to Load Terminal

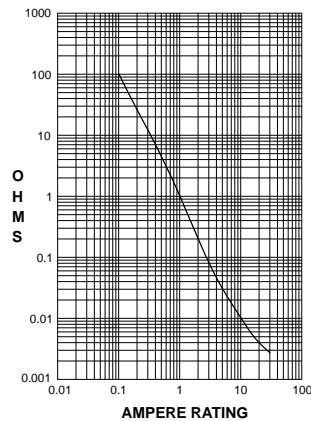

Ampere Rating

| CURRENT (AMPS) | TOLERANCE (%) |
|----------------|---------------|
| 0.10 - 5.0 | ± 15 |
| 5.10 - 20.0 | ± 25 |
| 20.10 - 30.0 | ± 35 |

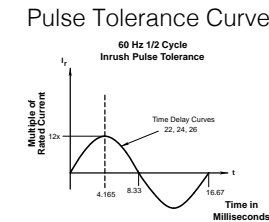

Leakage To Ground

Standard Must Trip 120/240VAC 60 Hz
 Leakage Current Ratings 5 & 30 milliamps. 5± 1mA
 For other ratings, consult factory.
 Trip Time 300 ms Max. @ 100%, 40ms Max. @ 500% of must trip leakage current.
 Test Button On unit face along side of actuator.

Mechanical

Endurance 10,000 ON-OFF operations @ 6 per minute; with rated Current & Voltage.
 Trip Free All PB-Series Circuit Breakers will trip on overload or ground fault, even when Handle is forcibly held in the ON position.
 Trip Indication The operating Handle moves positively to the OFF position when an overload or ground fault causes the breaker to trip.

Physical

Number of Poles 1 - 3 poles, where the third pole is neutral
 Internal Circuit Config. Series Trip
 Weight Approximately 65 grams/pole. (2.32 ounces/pole.)
 Standard Colors Housing- Black; Actuator - See Ordering Scheme.

Environmental

Designed and tested in accordance with requirements of specification MIL-PRF- 55629 and MIL-STD-202 as follows:
 Shock Withstands 100 Gs, 6ms, sawtooth while carrying rated current per Method 213, Test Condition "1". Ultra-short curves tested @ 90% of rated current.
 Vibration Withstands 0.060" excursion from 10-55 Hz, and 10 Gs 55-500 Hz, at rated current per Method 204C, Test Condition A. Instantaneous and ultrashort curves tested at 90% of rated current.
 Moisture Resistance Method 106D, i.e., ten 24-hour cycles @ + 25°C to +65°C, 80-98% RH.
 Salt Spray Method 101, Condition A (90-95% RH @ 5% NaCl Solution, 96 hrs).
 Thermal Shock Method 107D, Condition A (Five cycles @ -55°C to +25°C to +85°C to +25°C).
 Operating Temperature -35° C to +65° C
 Corrosion Tested FMG Test. 3 weeks @ 30°C 75% RH, 100ppb H2S, 20ppb Cl2, 200ppb NO2

Agency Certifications

UL Listed
 UL Standard 489 Circuit Breakers, Molded Case, (Guide DIVQ, File E129899)
 UL Standard 1077 Supplementary Protectors
 UL Standard 1053 Ground Fault Sensing and Relaying Equipment

*Manufacturer reserves the right to change product specification without prior notice.

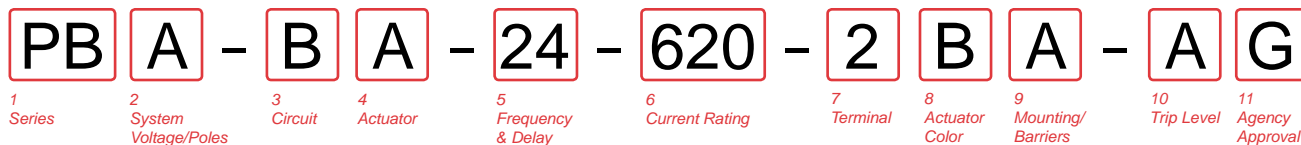

1 SERIES
PB

2 SYSTEM VOLTAGE / POLES
A 120 VAC single phase, one pole
B 120/240 VAC single phase, two pole
C 120/240 VAC single phase with switched neutral, three pole
D 120 VAC two pole with switched neutral

3 CIRCUIT
B Series Trip (Current)

4 ACTUATOR 1
Handle
A one per pole
B one per multipole unit
Two Color Curved Visi-Rocker
C Indicate ON, vertical legend
D Indicate ON, horizontal legend
F Indicate OFF, vertical legend
G Indicate OFF, horizontal legend
Single Color Curved Rocker
J Vertical legend
K Horizontal legend
Two Color Flat Visi-Rocker
1 Indicate OFF, vertical legend
2 Indicate OFF, horizontal legend
Single Color Flat Rocker
3 Vertical legend
4 Horizontal legend

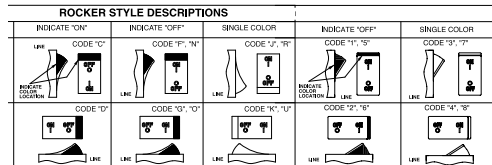

5 FREQUENCY & DELAY
22 60Hz Short
24 60Hz Medium
26 60Hz Long

6 CURRENT RATING (AMPERES)

| CODE | AMPERES | CODE | AMPERES | CODE | AMPERES | CODE | AMPERES |
|------|---------|------|---------|------|---------|------|---------|
| 210 | 0.100 | 285 | 0.850 | 450 | 5.000 | 712 | 12.500 |
| 215 | 0.150 | 290 | 0.900 | 455 | 5.500 | 613 | 13.000 |
| 220 | 0.200 | 295 | 0.950 | 460 | 6.000 | 614 | 14.000 |
| 225 | 0.250 | 410 | 1.000 | 465 | 6.500 | 615 | 15.000 |
| 230 | 0.300 | 512 | 1.250 | 470 | 7.000 | 616 | 16.000 |
| 235 | 0.350 | 415 | 1.500 | 475 | 7.500 | 617 | 17.000 |
| 240 | 0.400 | 517 | 1.750 | 480 | 8.000 | 618 | 18.000 |
| 245 | 0.450 | 420 | 2.000 | 485 | 8.500 | 620 | 20.000 |
| 250 | 0.500 | 522 | 2.250 | 490 | 9.000 | 622 | 22.000 |
| 255 | 0.550 | 425 | 2.500 | 495 | 9.500 | 624 | 24.000 |
| 260 | 0.600 | 527 | 2.750 | 610 | 10.000 | 625 | 25.000 |
| 265 | 0.650 | 430 | 3.000 | 710 | 10.500 | 630 | 30.000 |
| 270 | 0.700 | 435 | 3.500 | 611 | 11.000 | | |
| 275 | 0.750 | 440 | 4.000 | 711 | 11.500 | | |
| 280 | 0.800 | 445 | 4.500 | 612 | 12.000 | | |

7 TERMINAL 2
1³ Push-On 0.250 Tab (Q.C.)
2 Screw 8-32 w/upturned lugs
3 Screw 8-32 (Bus Type)
4 Screw 10-32 w/upturned lugs
5 Screw 10-32 (Bus Type)
B Screw M5 w/upturned lugs
C Screw M4 w/upturned lugs
E Screw M4 (Bus Type)
H Screw M5 (Bus Type)

8 ACTUATOR COLOR & LEGEND

| Handle Actuator Color | I-O | ON-OFF | Dual | Rocker Actuator Color Single | Color Visi-Rocker |
|-----------------------|-----|--------|------|------------------------------|-------------------|
| White | A | B | 1 | Black | White |
| Black | C | D | 2 | White | N/A |
| Red | F | G | 3 | White | Red |
| Green | H | J | 4 | White | Green |
| Blue | K | L | 5 | White | Blue |
| Yellow | M | N | 6 | Black | Yellow |
| Gray | P | Q | 7 | Black | Gray |
| Orange | R | S | 8 | Black | Orange |

9 MOUNTING/BARRIERS
 MOUNTING STYLE
Threaded Insert, 2 per pole
A 6-32 X 0.195 inches yes
B ISO M3 x 5mm yes

10 LEAKAGE CURRENT TRIP LEVEL - MAX. TRIP CURRENT
A 5 MA (CLASS A GFCI) ^{3,4}
E 30 MA (ELCI)

11 AGENCY APPROVAL
G UL489 Listed, CSA Certified
C UL1077
I UL1077/UL1500 Ignition Protected ⁵

- Notes:
 1 Actuator Code:
 A: Handle tie pin spacer(s) and retainers provided unassembled with multi-pole units.
 B: Handle location as viewed from front of breaker:
 2 pole - left pole 3 pole - center pole
 2 Screw Terminals are recommended on ratings greater than 20 amps.
 3 Available with leakage current trip level - Max trip current code E, and agency approval C.
 4 30mA per UL1053, available with agency approval codes C & G.
 5 UL1500 only available with 30MA trip level.

Dimensional Specifications: in. [mm]

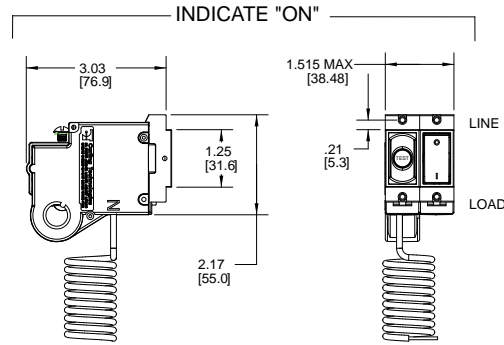

1-POLE 120 VAC VERSION

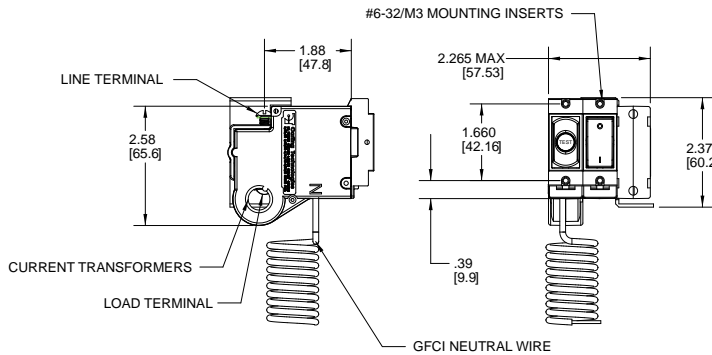
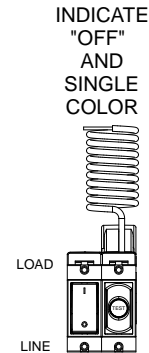

2-POLE 120/240 VAC VERSION

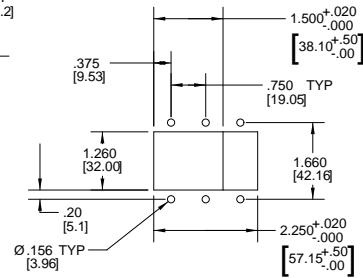

PANEL CUTOUT

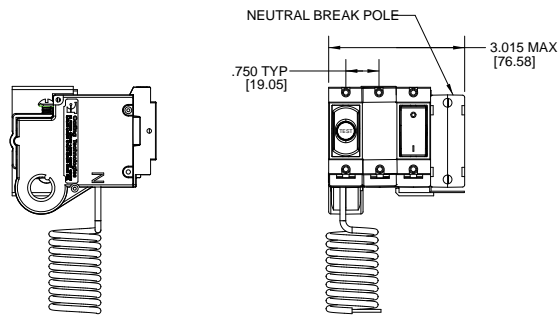

2-POLE 120/240 VAC WITH NEUTRAL BREAK

TERMINAL DIMENSIONAL DETAIL & RATING

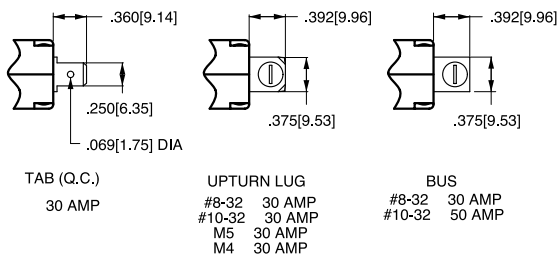

| TABLE A TIGHTENING TORQUE SPECIFICATIONS | |
|--|------------------------------|
| THREAD SIZE | TORQUE |
| #6-32 & M3 MOUNTING HARDWARE | 7-9 IN-LBS [0.8-1.0 NM] |
| #8-32 & M4 THREAD TERMINAL SCREW | 12-15 IN-LBS [1.4-1.7 NM] |
| #10-32 & M5 THREAD TERMINAL SCREW | 15-20 IN-LBS [1.7-2.3 NM] |

Notes:
1 All dimensions are in inches [millimeters].
2 Tolerance ±.020 [5.1] unless otherwise specified.

Dimensional Specifications: in. [mm]

TYPICAL 1-POLE 120 VAC VERSION

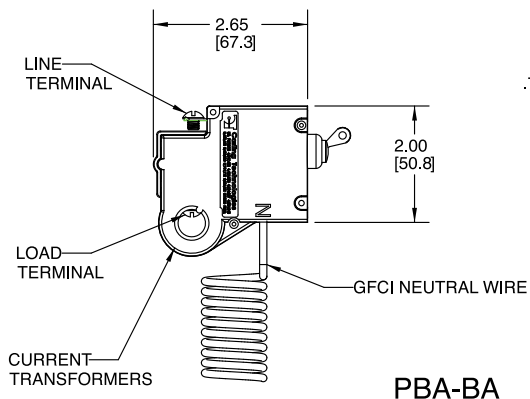

TYPICAL 2-POLE 120/240 VAC WITH NEUTRAL BREAK VERSION

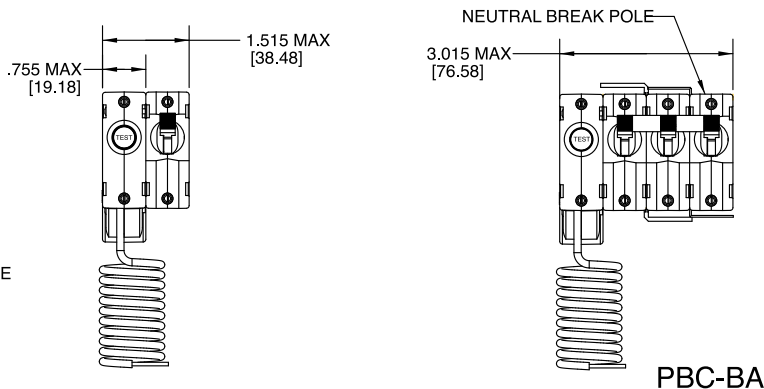

TYPICAL 2-POLE 120/240 VAC VERSION

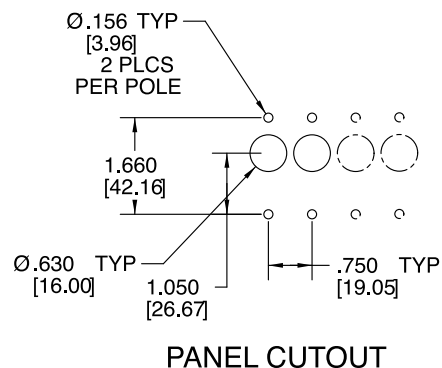
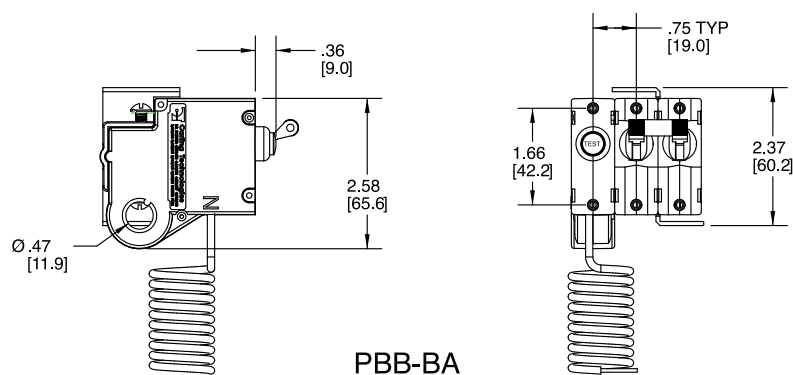

- Notes:
- 1 All dimensions are in inches [millimeters].
 - 2 Tolerance ± 0.020 [51] unless otherwise specified.

120 VAC with Switched Neutral

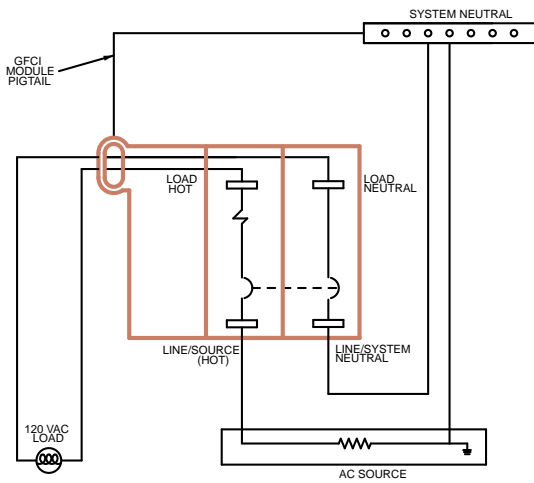

120 VAC WITH SWITCHED NEUTRAL

120 VAC without Switched Neutral

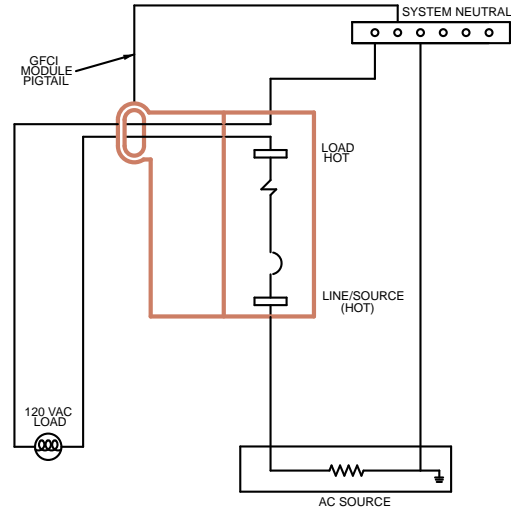

120 VAC WITHOUT SWITCHED NEUTRAL

120/240 VAC with Switched Neutral

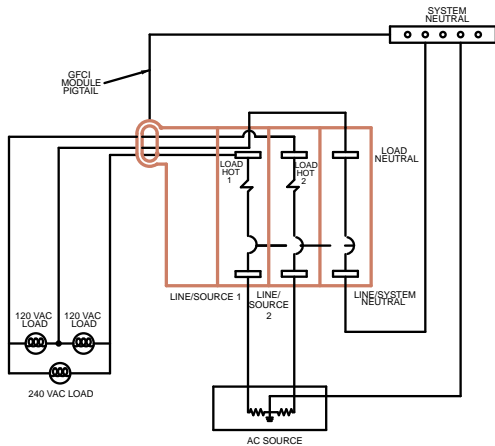

120 VAC WITH SWITCHED NEUTRAL

120/240 VAC without Switched Neutral

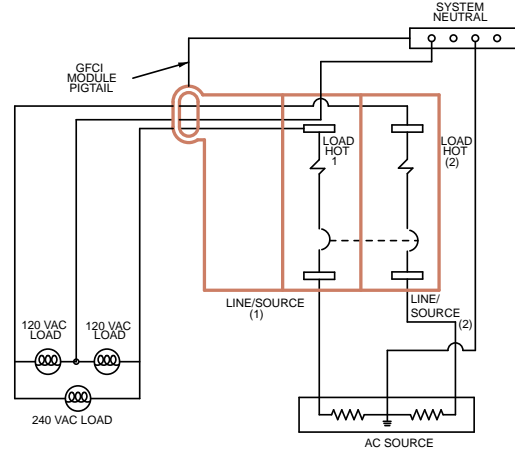

120 VAC WITHOUT SWITCHED NEUTRAL

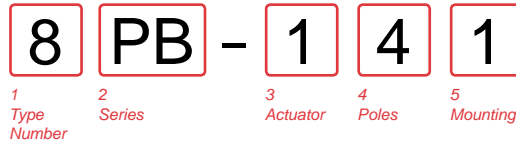

1 TYPE NUMBER
8 Circuit Breaker Assembly

2 SERIES
PB

3 ACTUATOR TYPE
1 Handle, one per pole
2 Handle, one per multipole unit
A Rocker²

4 POLES PER UNIT - INCLUDING ELECTRONIC MODULE
2 Two
3 Three
4 Four

5 MOUNTING SCREWS / PLATE MATERIAL¹
1 6-32 Thread Phillips Head
2 M-3 Thread Phillips Head
3 6-32 Thread Slotted Head
4 M-3 Thread Slotted Head
5 6-32 Thread Phillips Head with Stainless Steel Plate
6 M-3 Thread Phillips Head with Stainless Steel Plate
7 6-32 Thread Slotted Head with Stainless Steel Plate
8 M-3 Thread Slotted Head with Stainless Steel Plate

Notes:
1 Screws supplied to accommodate mounting panel thickness of 1/8" ± 1/32". Consult Factory for additional options
2 Available for Flat and Curved Rocker options - No Rockerguard Bracket

Handle Style Panel Seal

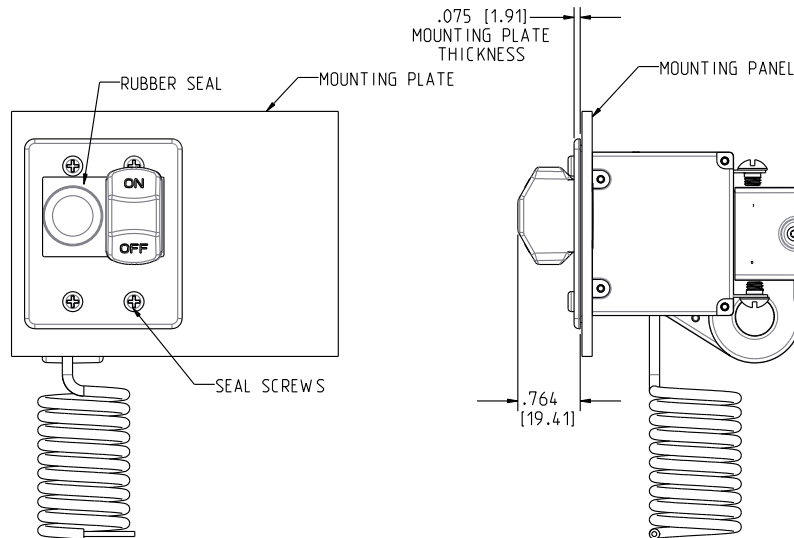

Rocker Style Panel Seal

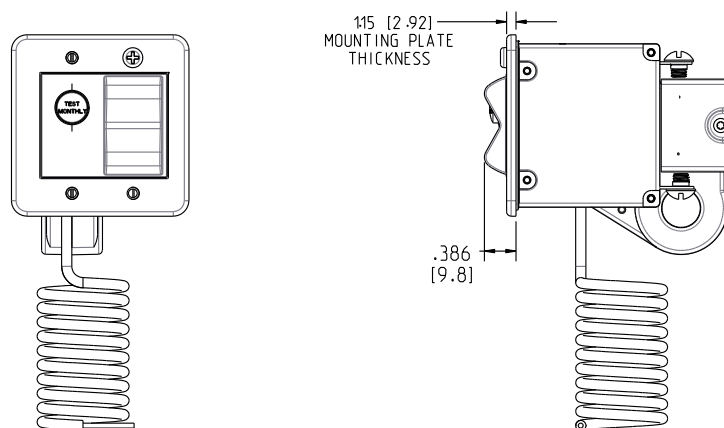

Handle Actuator

HANDLE, 1 PER POLE

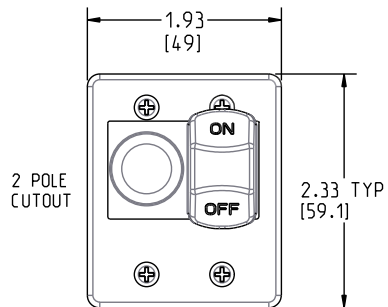

8PB-12

HANDLE, 1 PER MULTIPOLE UNIT

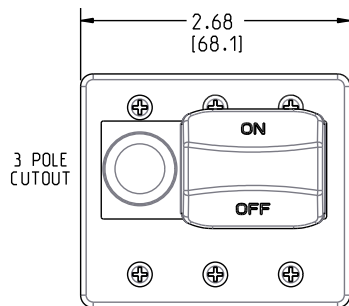

8PB-13

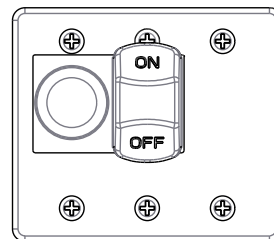

8PB-23

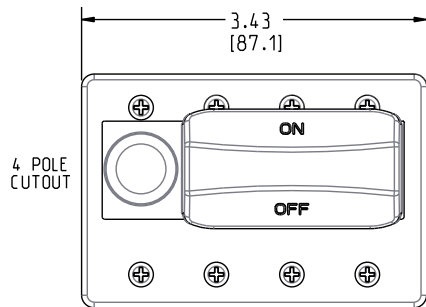

8PB-14

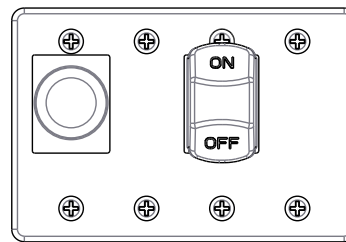

8PB-24

Rocker Actuator

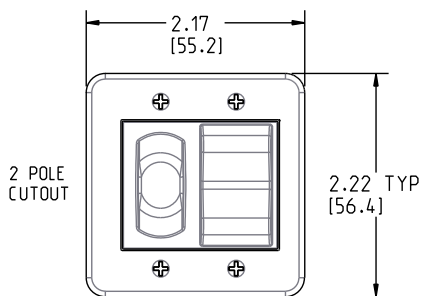

8PB-A2

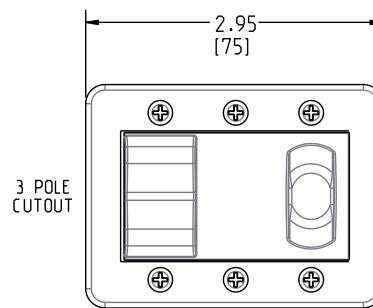

8PB-A3

Time Delay Curves

Instantaneous

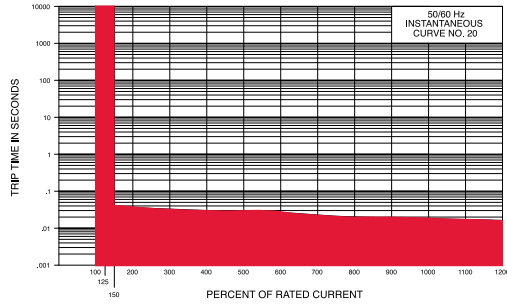

Medium

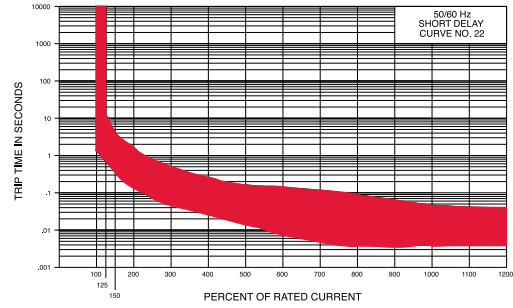

Short

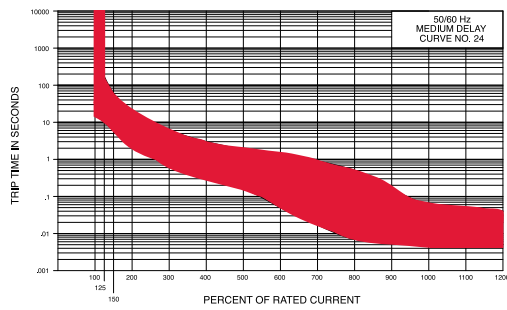

Long

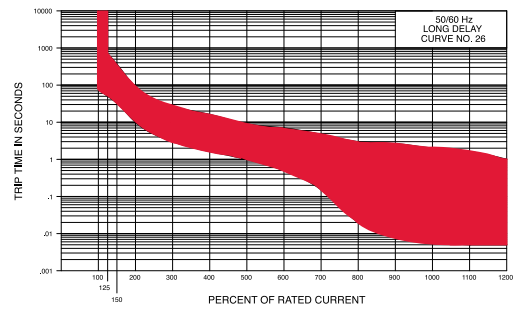

PC-Series

GFCI/ELCI & PANEL SEAL

The PC-Series, AC Residual Current Circuit Breaker with Overcurrent Protection (RCBO), combines the ground fault protection of a GFCI with the familiar overcurrent tripping characteristics of a normal circuit breaker. The PC-Series utilizes the hydraulic-magnetic principle which provides precise operation and performance even when exposed to extremely hot and/or cold application environments.



Resources:

Download 3D CAD Files

[IGS >](#) [STP >](#)

Product Highlights:

- ◆ Overload, short circuit and ground fault protection in a single package
- ◆ Handle style actuators and rocker style “acuguard”
- ◆ Wiping Contacts - Mechanical linkage with two-step actuation - cleans contacts, provides high, positive contact pressure & longer contact life
- ◆ A trip-free mechanism, a safety feature which makes it impossible to manually hold the contacts closed during overload or fault conditions.
- ◆ A common trip linkage between poles ensures that an overload in one pole will trip all adjacent poles.
- ◆ Front panel mounting
- ◆ Integral push-to-test button
- ◆ Two integrated LED indicators show if a breaker is closed w/ Line Voltage present, or has opened due to leakage current, opened due to overcurrent, or closed w/ no Line Voltage present.
- ◆ Optional Hot/Neutral reversal detection and protection

Benefits:

- ◆ Increases safety around boats, marinas and generators
- ◆ Protects against electrical shock hazards in areas near water
- ◆ Protects against defects in the wires & conductors
- ◆ Reduces fire and shock hazards from defects in permanently installed appliances such as water heaters, battery chargers, lighting fixtures, etc.
- ◆ Detects low level ground faults, which do not trip ordinary circuit breakers, that can lead to fires and shock hazards for boating occupants

Typical Applications:

- ◆ Marine
- ◆ Generators
- ◆ Lighting

PC-Series Switch

DESIGN FEATURES

MOUNTING PLATE

Available in stainless steel or zinc chromate plated carbon steel



OPTIONAL SEAL

IP66/67 panel seals provide ideal protection against salt spray, ozone, dust, water and most acids



LEDs

Two separate lights that indicate power and ground fault leakage

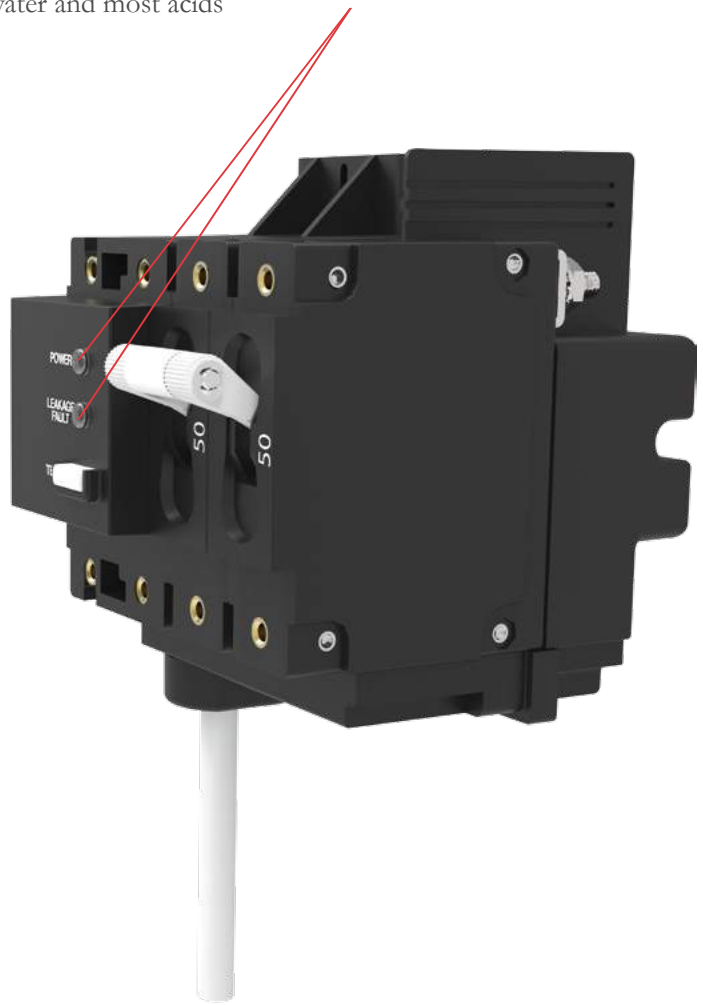

Electrical Tables

Table A: UL Listed & CSA Certified configurations as a Ground Fault Circuit Interruptor

| PC-SERIES TABLE A: UL Listed / CSA 22.2 No. 144.1 Configurations as a Ground Fault Circuit Interruptor | | | | | | | |
|--|------------|-----------|-------|-----------------------|-------------------------------|-------------------------------------|---|
| Circuit Configuration | Voltage | | | Current Rating (Amps) | Short Circuit Capacity (Amps) | Ground Fault Trip Level (Milliamps) | Notes |
| | Max Rating | Frequency | Phase | | | | |
| Series | 120 | 50 / 60 | 1 | 1 - 50 | 5000 | 6 | 1 or 2 Poles. One pole of a two pole unit must be Neutral |
| | 120 / 240 | 50 / 60 | 1 | 1 - 50 | 5000 | 6 | 1 or 2 Poles. One pole of a three pole unit must be Neutral |

Table B: UL Recognized as an Earth Leakage Circuit Interruptor - 120 and 120/240V

| PC-SERIES TABLE B: UL Recognized Configurations as an Earth Leakage Circuit Interruptor | | | | | | | |
|---|------------|-----------|-------|-----------------------|-------------------------------|-------------------------------------|---|
| Circuit Configuration | Voltage | | | Current Rating (Amps) | Short Circuit Capacity (Amps) | Ground Fault Trip Level (Milliamps) | Notes |
| | Max Rating | Frequency | Phase | | | | |
| Series | 120 | 50 / 60 | 1 | 1 - 50 | 5000 | 30 | 1 or 2 Poles. One pole of a two pole unit must be Neutral |
| | 120 / 240 | 50 / 60 | 1 | 1 - 50 | 5000 | 30 | 1 or 2 Poles. One pole of a three pole unit must be Neutral |
| Series Ignition Protection | 120 | 50 / 60 | 1 | 1 - 50 | 3000 | 30 | 1 or 2 Poles. One pole of a two pole unit must be Neutral |
| | 120 / 240 | 50 / 60 | 1 | 1 - 50 | 5000 | 30 | 1 or 2 Poles. One pole of a three pole unit must be Neutral |

Table C: UL Recognized as an Earth Leakage Circuit Interruptor - 240V

| PC-SERIES TABLE C: UL Recognized Configurations as an Earth Leakage Circuit Interruptor - 240V | | | | | | | |
|--|------------|-----------|-------|-----------------------|-------------------------------|-------------------------------------|--|
| Circuit Configuration | Voltage | | | Current Rating (Amps) | Short Circuit Capacity (Amps) | Ground Fault Trip Level (Milliamps) | Notes |
| | Max Rating | Frequency | Phase | | | | |
| Series | 240 | 50 / 60 | 1 | 1 - 30 | 5000 | 30 | 2 or 3 Poles. One pole of a two pole unit must be Neutral. Suffix 11 |
| Series Ignition Protection | 240 | 50 / 60 | 1 | 1 - 50 | 5000 | 30 | 2 or 3 Poles. One pole of a three pole unit must be Neutral. Suffix 12 |

Agency Certifications

| | |
|--------------------|---|
| UL Standard 489 | Circuit Breakers, Molded Case, (Guide DIVQ, File E129899) |
| UL Standard 1077 | Supplementary Protectors |
| CSA 22.2 No. 144.1 | Class A Ground Fault Circuit Interrupters |
| UL Standard 1053 | Ground Fault Sensing and Relaying Equipment |
| UL Standard 1500 | Ignition Protection |

Electrical

Current Ratings 1 - 50 Amps maximum
 Voltage Rating 120VAC, 120/240VAC, 240VAC
 Current Trip Level 30mA & 6mA
 Current Trip Time For 30mA leakage trip:
 ≤ 22.2mA, shall not trip
 30mA, shall trip within .10 seconds
 The above complies with & ABYC E11. For 6mA leakage trip: ≤25ms
 50/60 Hz for 30mA leakage trip
 60 Hz for 6mA leakage trip

Operating Frequency 5,000 Amps

Interrupt Capacity
 Impedance

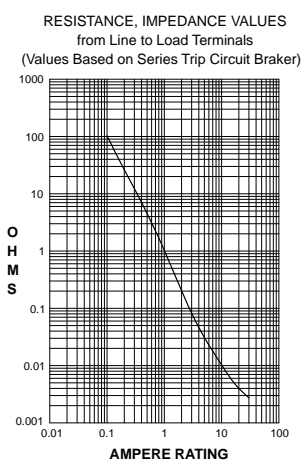

| CURRENT (AMPS) | TOLERANCE (%) |
|----------------|---------------|
| 0.10 - 5.0 | ± 15 |
| 5.10 - 20.0 | ± 25 |
| 20.10 - 50.0 | ± 35 |

Innovative Features

Indicator Two integrated LEDs, Red & Green
 ♦ **Green LED On, Red LED Off**
 Line Voltage is present, the breaker is closed, and the device is protecting the circuits against over current and leakage current.
 ♦ **Green LED Off, Red LED On**
 The device has detected leakage current and has opened the circuit breaker.
 ♦ **Green LED Flashing, Red LED Off**
 The circuit breaker has opened due to over current or has been turned off manually
 ♦ **Green LED Off, Red LED Off**
 Line Voltage is not present
 ♦ **Green LED Flashing, Red LED Off, Amber LED ON**
 Indicates Hot & Neutral are reversed and the circuit breaker is open

Neutral Protection When neutral is grounded on load side of circuit

Test Button Located on Ground Fault Module

Mechanical

Endurance 10,000 ON-OFF operations @ 6 per minute; with rated Current & Voltage.
 Trip Free Trips on short circuit, overload or leakage to ground, even when actuator is forcibly held in the "On" position

Physical

Number of Poles (Breakers only) 1-pole (1 Circuit Breaker + 1 GFCI Sensor Module), 120V
 2-pole (2 Circuit Breakers + 1 GFCI Sensor Module), 120/240V or 120V with Neutral Break. 240VAC two pole. 3-pole 120/240V with Neutral Break (Sensor module has 2 pole width) Circuit Breaker Line Side: #10-32, Threaded stud. GFCI Sensor Module Load Side: #10-32 threaded stud. Neutral pigtail. Front Panel, #6-32 and M3 threaded inserts.

Termination
 Mounting
 Actuator Handle, Flat Rocker, Curved Rocker (with or without rocker guard), Push-to-Reset Rocker

Environmental

Designed and tested in accordance with requirements of specification MIL-PRF- 55629 and MIL-STD-202G as follows:

Shock Withstands 100 G, 6ms, sawtooth at rated current per Method 213, Test Condition "I".

Vibration Withstands 0.06" excursion from 10-55 Hz, and 10 G 55-500 Hz, a rated current per Method 204C, Test Condition A. Instantaneous & ultrashort curves tested at 90% of rated current.

Moisture Resistance 93% RH at 30°C for 168 Hours.
 Operating Temperature -35°C to +66°C
 Corrosion **Humidity:** 30±2°C, 70±2% relative humidity
Mixed Flowing Gases: 100 ppb H₂S, 20 ppb Cl₂, 200±50 ppb NO₂

*Manufacturer reserves the right to change product specification without prior notice.

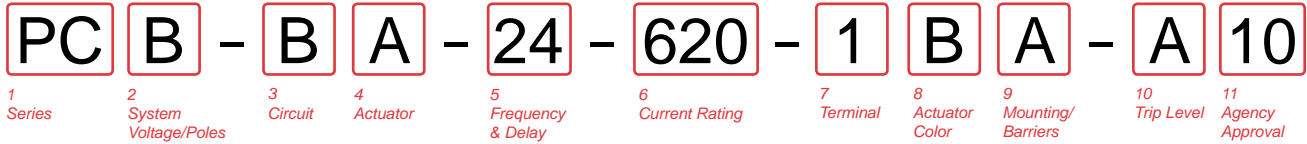

1 SERIES
PC

2 SYSTEM VOLTAGE / POLES
A 120 VAC single phase, 1 pole
B 120/240 VAC single phase, 2 pole
C 120/240 VAC single phase with switched neutral, 3 pole
D 120 VAC single phase with switched neutral, 2 pole
E 120 VAC single phase with reversed polarity indicator, 2 pole
F 120/240 VAC single phase with reversed polarity indicator, 3 pole
G 240 VAC single phase, 2 pole

3 CIRCUIT
B Series Trip (Current)

4 ACTUATOR
Handle
A 1 per breaker pole
B 1 per unit
Two Color Curved Visi-Rocker
C Indicate ON, vertical legend
D Indicate ON, horizontal legend
F Indicate OFF, vertical legend
G Indicate OFF, horizontal legend
Single Color Curved Rocker
J Vertical legend
K Horizontal legend
Two Color Curved Visi-Rocker Push-to-Reset
N Indicate OFF, Vertical legend
O Indicate OFF, Horizontal legend

Single Color Curved Rocker Push-to-Reset
R Vertical legend
U Horizontal legend
Two Color Flat Visi-Rocker
1 Indicate OFF, vertical legend
2 Indicate OFF, horizontal legend
Single Color Flat Rocker
3 Vertical legend
4 Horizontal legend
Two Color Flat Visi-Rocker Push-to-Reset
5 Indicate OFF, vertical legend
6 Indicate OFF, horizontal legend
Single Color Flat Rocker Push-to-Reset
7 Vertical legend
8 Horizontal legend

| ROCKER STYLE DESCRIPTIONS | | | | |
|---------------------------|----------------|---------------|----------------|---------------|
| INDICATE "ON" | INDICATE "OFF" | SINGLE COLOR | INDICATE "OFF" | SINGLE COLOR |
| CODE "1" | CODE "1" | CODE "1", "R" | CODE "1", "S" | CODE "1", "T" |
| | | | | |
| | | | | |
| | | | | |
| | | | | |
| | | | | |

5 FREQUENCY & DELAY
20 50/60Hz Instantaneous
21 50/60Hz Ultra Short
22 50/60Hz Short
24 50/60Hz Medium
26 50/60Hz Long

6 CURRENT RATING (AMPERES)

| CODE | AMPERES | CODE | AMPERES | CODE | AMPERES | CODE | AMPERES |
|------|---------|------|---------|------|---------|------|---------|
| 410 | 1.000 | 445 | 4.500 | 610 | 10.000 | 618 | 18.000 |
| 512 | 1.250 | 450 | 5.000 | 710 | 10.500 | 620 | 20.000 |
| 415 | 1.500 | 455 | 5.500 | 611 | 11.000 | 622 | 22.000 |
| 517 | 1.750 | 460 | 6.000 | 711 | 11.500 | 624 | 24.000 |
| 420 | 2.000 | 465 | 6.500 | 612 | 12.000 | 625 | 25.000 |
| 522 | 2.250 | 470 | 7.000 | 712 | 12.500 | 630 | 30.000 |
| 425 | 2.500 | 475 | 7.500 | 613 | 13.000 | 635 | 35.000 |
| 527 | 2.750 | 480 | 8.000 | 614 | 14.000 | 640 | 40.000 |
| 430 | 3.000 | 485 | 8.500 | 615 | 15.000 | 650 | 50.000 |
| 435 | 3.500 | 490 | 9.000 | 616 | 16.000 | | |
| 440 | 4.000 | 495 | 9.500 | 617 | 17.000 | | |

7 TERMINAL
1 Stud, 10-32 threaded

8 ACTUATOR COLOR & LEGEND

| Handle | Actuator Color | I-O | ON-OFF | Dual | Single | Rocker Actuator Color | Visi-Rocker |
|--------|----------------|-----|--------|------|--------|-----------------------|-------------|
| White | A | A | B | 1 | Black | White | White |
| Black | C | C | D | 2 | White | N/A | N/A |
| Red | F | F | G | 3 | White | Red | Red |
| Green | H | H | J | 4 | White | Green | Green |
| Blue | K | K | L | 5 | White | Blue | Blue |
| Yellow | M | M | N | 6 | Black | Yellow | Yellow |
| Gray | P | P | Q | 7 | Black | Gray | Gray |
| Orange | R | R | S | 8 | Black | Orange | Orange |

9 MOUNTING/BARRIERS

| ACTUATOR | MOUNTING STYLE | BARRIERS |
|----------|---|----------|
| A | 6-32 X 0.195 inches Threaded Insert, 2 per pole | yes |
| B | ISO M3 x 5mm Rockerguard Bezel Threaded Insert, 2 per pole | yes |
| C | 6-32 X 0.195 inches Standard Bezel with Recessed Off-Side Flat Rocker Threaded Insert, 2 per pole | yes |
| D | ISO M3 x 5mm | yes |
| E | 6-32 X 0.195 inches Push-to-Reset Bezel Threaded Insert, 2 per pole | yes |
| F | ISO M3 x 5mm | yes |
| G | 6-32 X 0.195 inches Push-to-Reset Bezel Threaded Insert, 2 per pole | yes |
| H | ISO M3 x 5mm | yes |

10 LEAKAGE CURRENT TRIP LEVEL - MAX. TRIP CURRENT
A 6 MA (CLASS A GFCI)
E 30 MA (ELCI) 1,2

11 AGENCY APPROVAL
AA without Approvals
10 CSA certified
11 UL 1053 1,2
12 UL 1053 & UL 1500 1,2

Notes:
 1 This device meets the requirements of ABCY E11.
 2 30mA per UL1053, available with agency approval codes 11 & 12.

INDICATE OFF / SINGLE COLOR
ROCKER ACTUATOR

HANDLE / INDICATE ON
ROCKER ACTUATOR

TERMINAL
LOCATIONS

PCA
120 VAC
VERSION

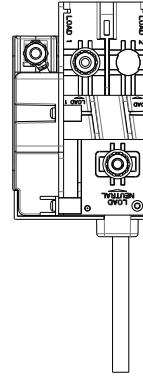
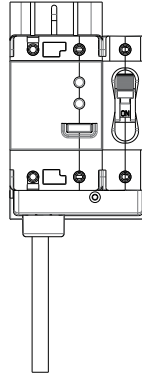
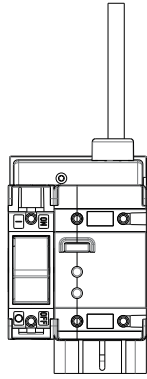

PCB
120/240 VAC
VERSION

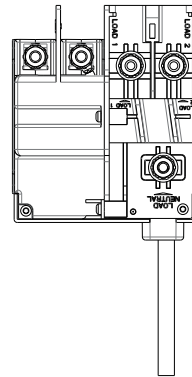
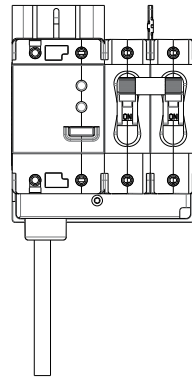
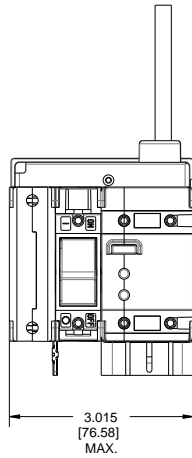

PCC
120/240 VAC
VERSION
W/ NEUTRAL BREAK

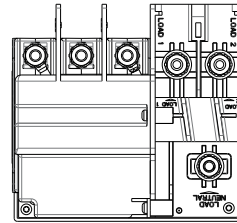
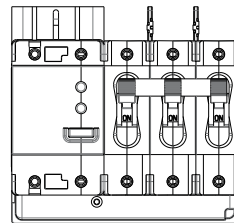
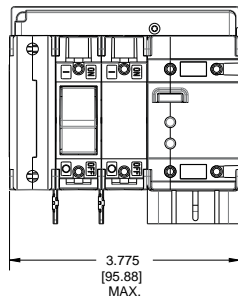

PCD
120 VAC
VERSION
W/NEUTRAL BREAK

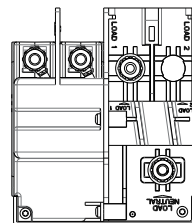
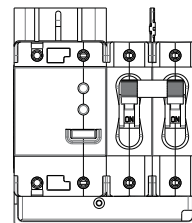
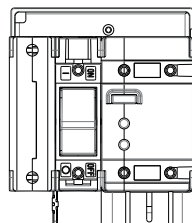

INDICATE OFF / SINGLE COLOR
ROCKER ACTUATOR

HANDLE / INDICATE ON
ROCKER ACTUATOR

TERMINAL
LOCATIONS

PCE
120 VAC VERSION
W/ REVERSE POLARITY
INDICATOR

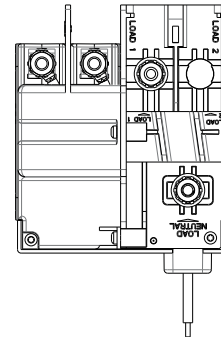
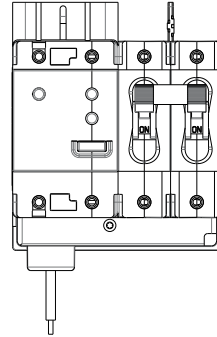
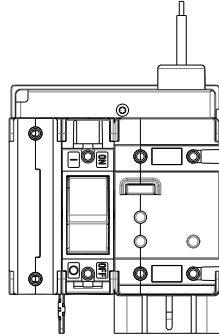

PCF
120/240 VAC VERSION
W/ REVERSE POLARITY
INDICATOR

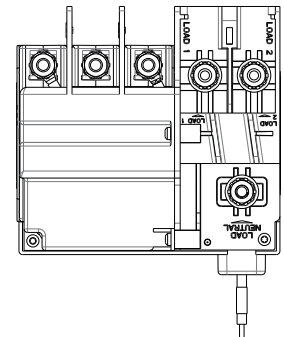
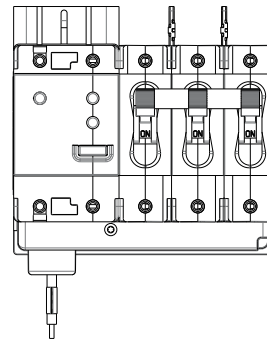
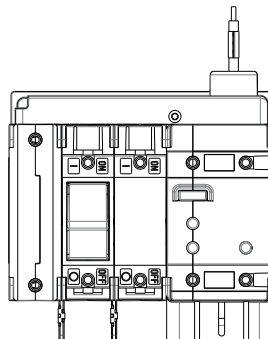

NOTE: NEUTRAL & GROUND PIGTAIL WIRES - SUPPLIED 12" LONG MIN. (CIRCUIT CODES A,B,E & F)

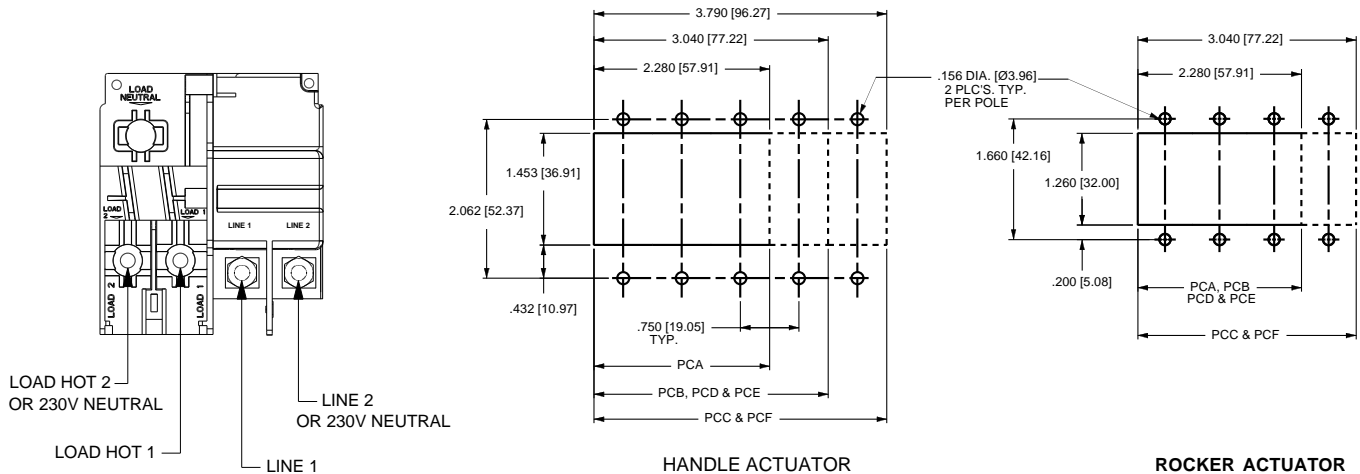

PANEL CUTOUT DETAIL
TOLERANCES ±.005 [1.12]

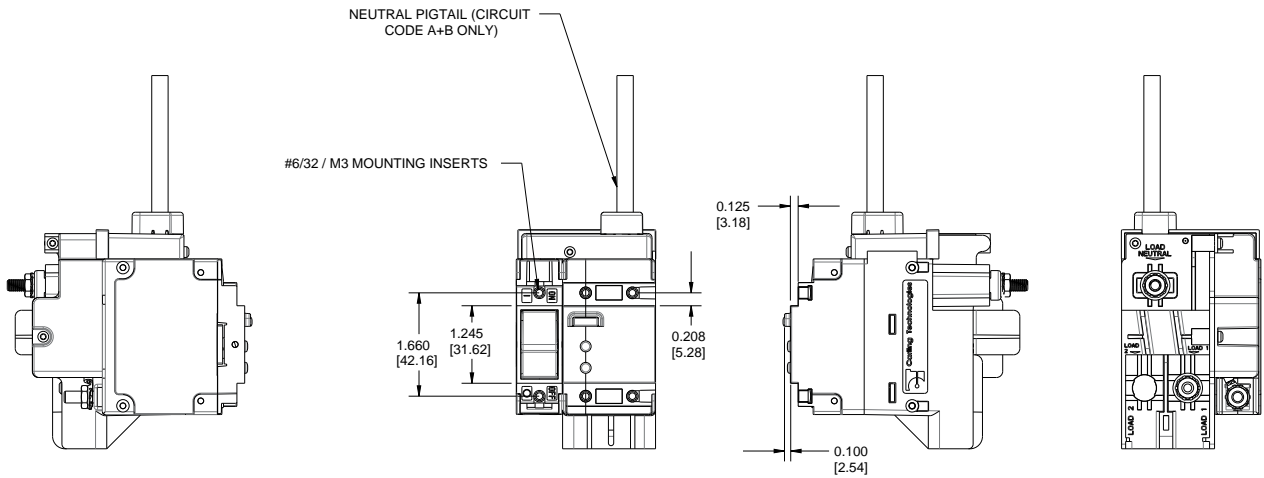
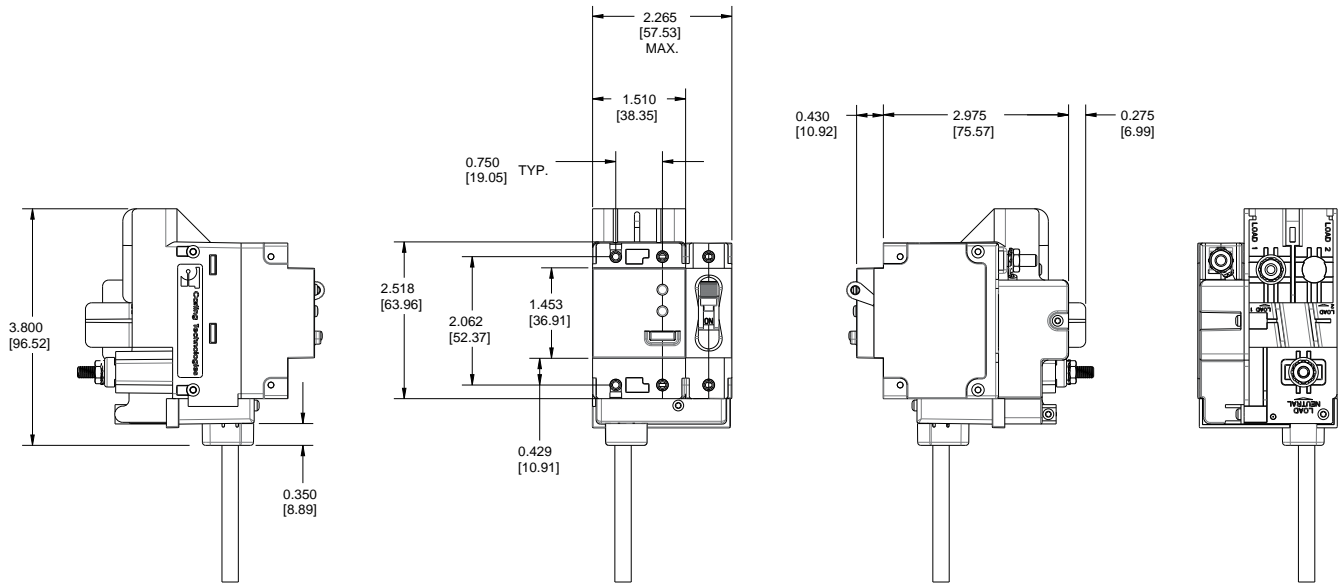

Notes:
For additional circuit breaker dimensions, reference the C-Series Breakers in the Carling Circuit Protection catalog

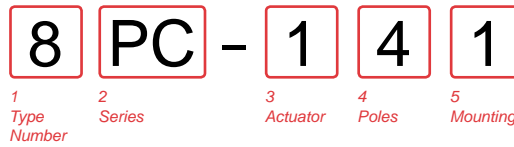

1 TYPE NUMBER
8 Circuit Breaker Assembly

2 SERIES
PC

3 ACTUATOR TYPE
1 Handle, one per pole
2 Handle, one per multipole unit
A Rocker²

4 POLES PER UNIT - INCLUDING ELECTRONIC MODULE
3 Three
4 Four
5 Five

5 MOUNTING SCREWS / PLATE MATERIAL¹
1 6-32 Thread Phillips Head
2 M-3 Thread Phillips Head
3 6-32 Thread Slotted Head
4 M-3 Thread Slotted Head
5 6-32 Thread Phillips Head w/ Stainless Steel Plate
6 M-3 Thread Phillips Head w/ Stainless Steel Plate
7 6-32 Thread Slotted Head w/ Stainless Steel Plate
8 M-3 Thread Slotted Head w/ Stainless Steel Plate

Notes:
1 Screws supplied to accommodate mounting panel thickness of 1/8" ± 1/32". Consult Factory for additional options
2 Available for Flat and Curved Rocker options - No Rockerguard Bracket

Handle Style Panel Seal

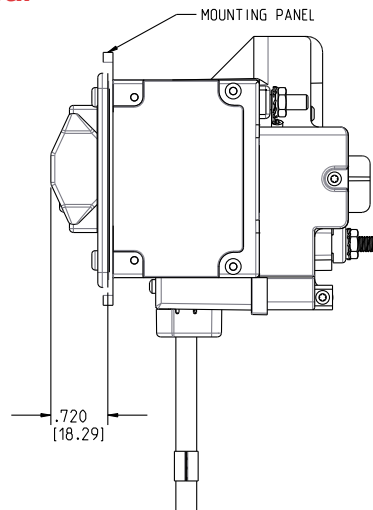
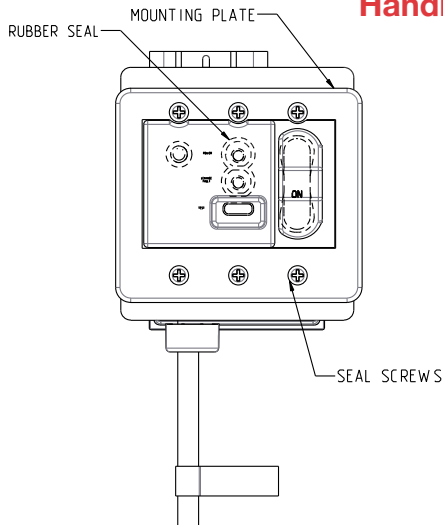

Rocker Style Panel Seal

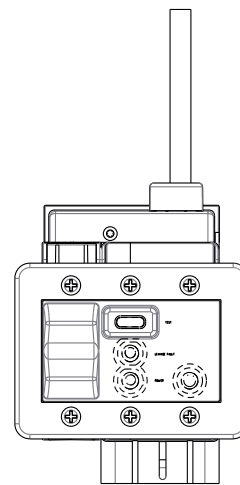
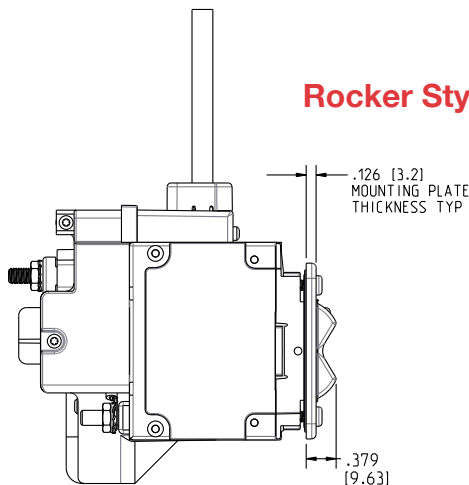

Handle Actuator

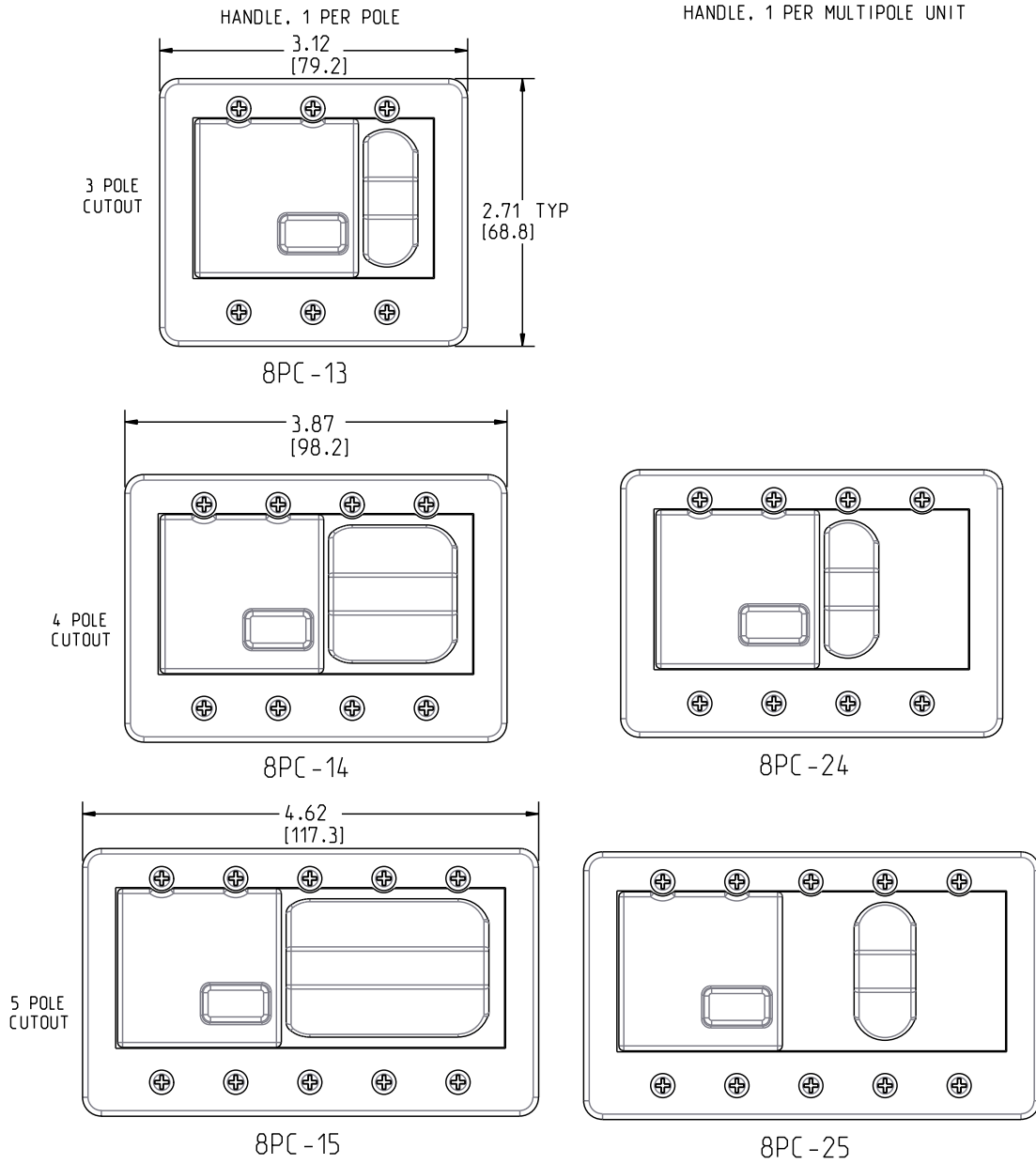

Rocker Actuator

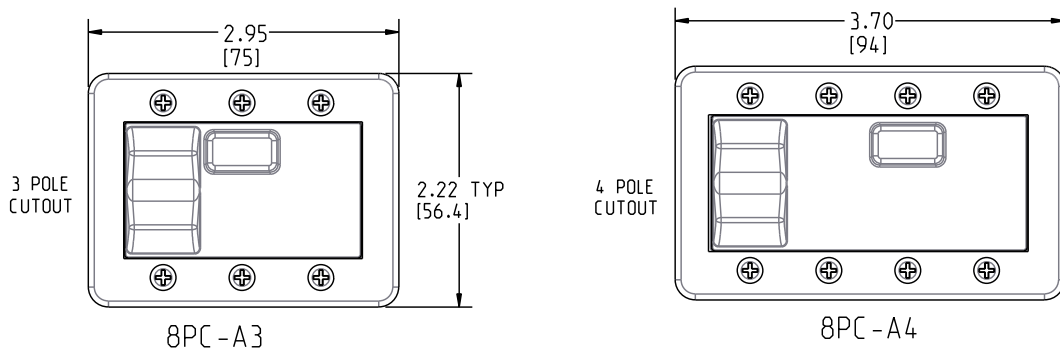

Time Delay Curves Instantaneous

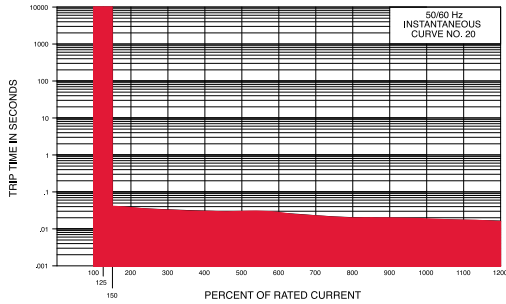

Medium

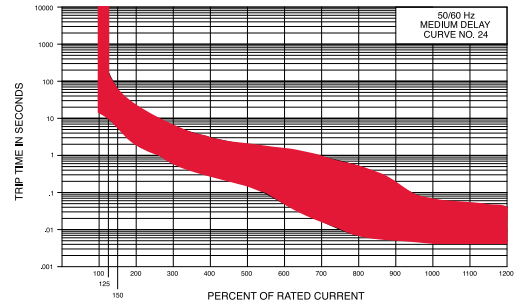

Ultra Short

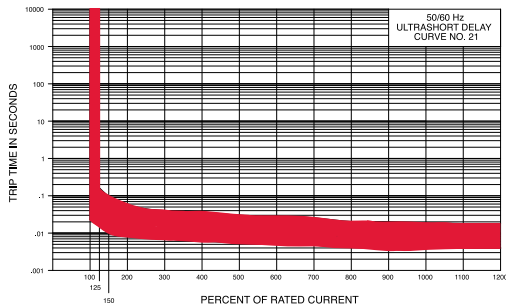

Long

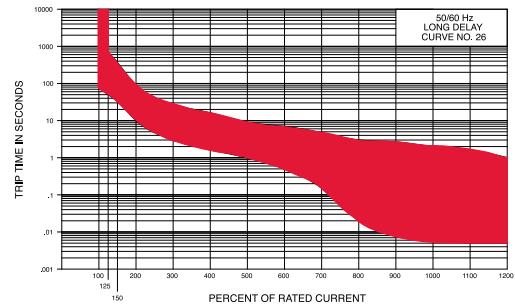

Short

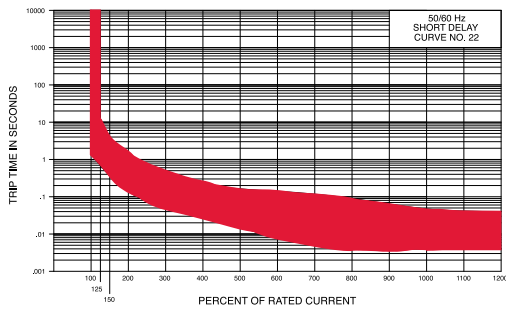

| Time Delay Values | | | | | | | | | |
|--------------------------|---------|-------------|-------------|-------------|-------------|-------------|-------------|-------------|-------------|
| Percent of Rated Current | | | | | | | | | |
| Delay | 100% | 125% | 150% | 200% | 400% | 600% | 800% | 1000% | 1200% |
| 20 | No Trip | May Trip | .040 MAX | .035 MAX | .030 MAX | .025 MAX | .020 MAX | .017 MAX | .015 MAX |
| 21 | No Trip | .014 - .150 | .011 - .095 | .008 - .055 | .006 - .035 | .005 - .027 | .005 - .021 | .004 - .018 | .004 - .017 |
| 22 | No Trip | .700 - 12.0 | .350 - 4.00 | .130 - 1.30 | .027 - .220 | .008 - .130 | .004 - .090 | .004 - .045 | .004 - .040 |
| 24 | No Trip | 10.0 - 160 | 6.00 - 60.0 | 2.20 - 20.0 | .300 - 3.00 | .050 - 1.30 | .007 - .500 | .005 - .060 | .005 - .040 |
| 26 | No Trip | 50.0 - 700 | 32.0 - 350 | 10.0 - 90.0 | 1.50 - 15.0 | .500 - 7.00 | .020 - 3.00 | .006 - 2.00 | .005 - 1.00 |

Notes:

Other time delay values available, consult factory.

Delay Curves 21,22,24,26: Breakers to hold 100% and must trip at 125% of rated current and greater within the time limit shown in this curve.

Delay Curve 20: Breakers to hold 100% and must trip at 150% of rated current and greater within the time limit shown in this curve.

All Curves: Curve data shown represents breaker response at ambient temperature of 77°F (25°C) with no preloading. Breakers are mounted in standard wall-mount position.

The minimum inrush pulse tolerance handling capability is 12 times the rated current. These values are based on a 60 Hz 1/2 cycle, 8.33 ms pulse.

There are several catalogs available featuring complete details on all Carling Technologies products. Below is a list of useful information such as catalogs, brochures and videos. Please visit our website at carlingtech.com or scan the QR codes below for complete details.

www.carlingtech.com



Watch Company Profile Video

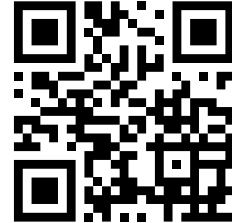

Switches & Controls

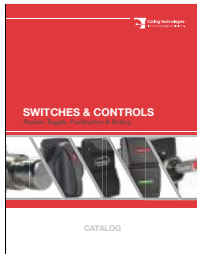

catalog

Complete line and ordering details for Switches & Control products including Rocker, Toggle, Pushbutton, and Rotary style switches.

Hydraulic-Magnetic

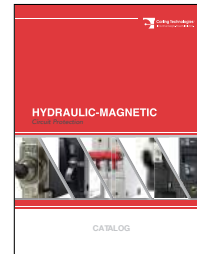

catalog

Complete line and ordering details for all hydraulic-magnetic circuit breakers.

Thermal

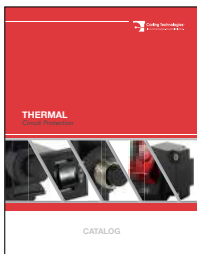

catalog

Complete line and ordering details for all thermal circuit breakers.

GFCI / ELCI



catalog

Complete line and ordering details for all GFCIs/ELCIs.

Marine



catalog

brochure

Complete line of ELCIs, thermal and hydraulic-magnetic circuit breakers specific for marine applications.

On-Off Highway



catalog

brochure

Complete line of switches, controls and custom solutions specific for on-off highway applications.

Renewable Energy

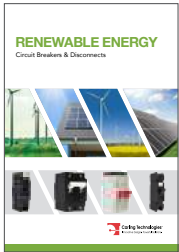

catalog

brochure

Complete line of circuit breakers and disconnect products specific for renewable energy applications.

Military

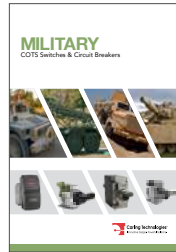

catalog

brochure

Complete line of COIS (*Commercial-Off-The-Shelf*) switches and circuit breakers specific for military applications.

Telecom/Datacom



catalog

brochure

Complete line of hydraulic-magnetic circuit breakers specific for telecom/datacom applications.

Industrial Automation



brochure

Complete line of switches and circuit breakers specific for industrial automation & controls applications.

Authorized Sales Representatives and Distributors

Click on a region of the map below to find your local representatives and distributors or visit www.carlingtech.com/findarep.



About Carling

Founded in 1920, Carling Technologies is a leading manufacturer of electrical and electronic switches and assemblies, circuit breakers, electronic controls, power distribution units, and multiplexed power distribution systems. With four ISO registered manufacturing facilities and technical sales offices worldwide, Carling Technologies Sales, Service and Engineering teams do much more than manufacture electrical components, they engineer powerful solutions! To learn more about Carling please visit www.carlingtech.com/company-profile.

To view all of Carling's environmental, quality, health & safety certifications please visit www.carlingtech.com/environmental-certifications

Worldwide Headquarters

Carling Technologies, Inc.
60 Johnson Avenue, Plainville, CT 06062-1177
Phone: 860.793.9281 **Fax:** 860.793.9231
Email: sales@carlingtech.com www.carlingtech.com

Northern Region Sales Office: nrsm@carlingtech.com
Southeast Region Sales Office: sersm@carlingtech.com
Midwest Region Sales Office: mrrsm@carlingtech.com
West Region Sales Office: wrsm@carlingtech.com
Latin America Sales Office: larsm@carlingtech.com

Asia-Pacific Headquarters

Carling Technologies, Asia-Pacific Ltd.,
Suite 1607, 16/F Tower 2, The Gateway, Harbour City,
25 Canton Road, Tsimshatsui, Kowloon, Hong Kong
Phone: Int + 852-2737-2277 **Fax:** Int + 852-2736-9332
Email: sales@carlingtech.com.hk

Shenzhen, China: shenzhen@carlingtech.com
Shanghai, China: shanghai@carlingtech.com
Pune, India: india@carlingtech.com
Kaohsiung, Taiwan: taiwan@carlingtech.com
Yokohama, Japan: japan@carlingtech.com

Europe | Middle East | Africa Headquarters

Carling Technologies LTD
4 Airport Business Park, Exeter Airport,
Clyst Honiton, Exeter, Devon, EX5 2UL, UK
Phone: Int + 44 1392.364422 **Fax:** Int + 44 1392.364477
Email: ltd.sales@carlingtech.com

Germany: gmbh@carlingtech.com
France: sas@carlingtech.com

