

CARLO GAVAZZI
Automation Components

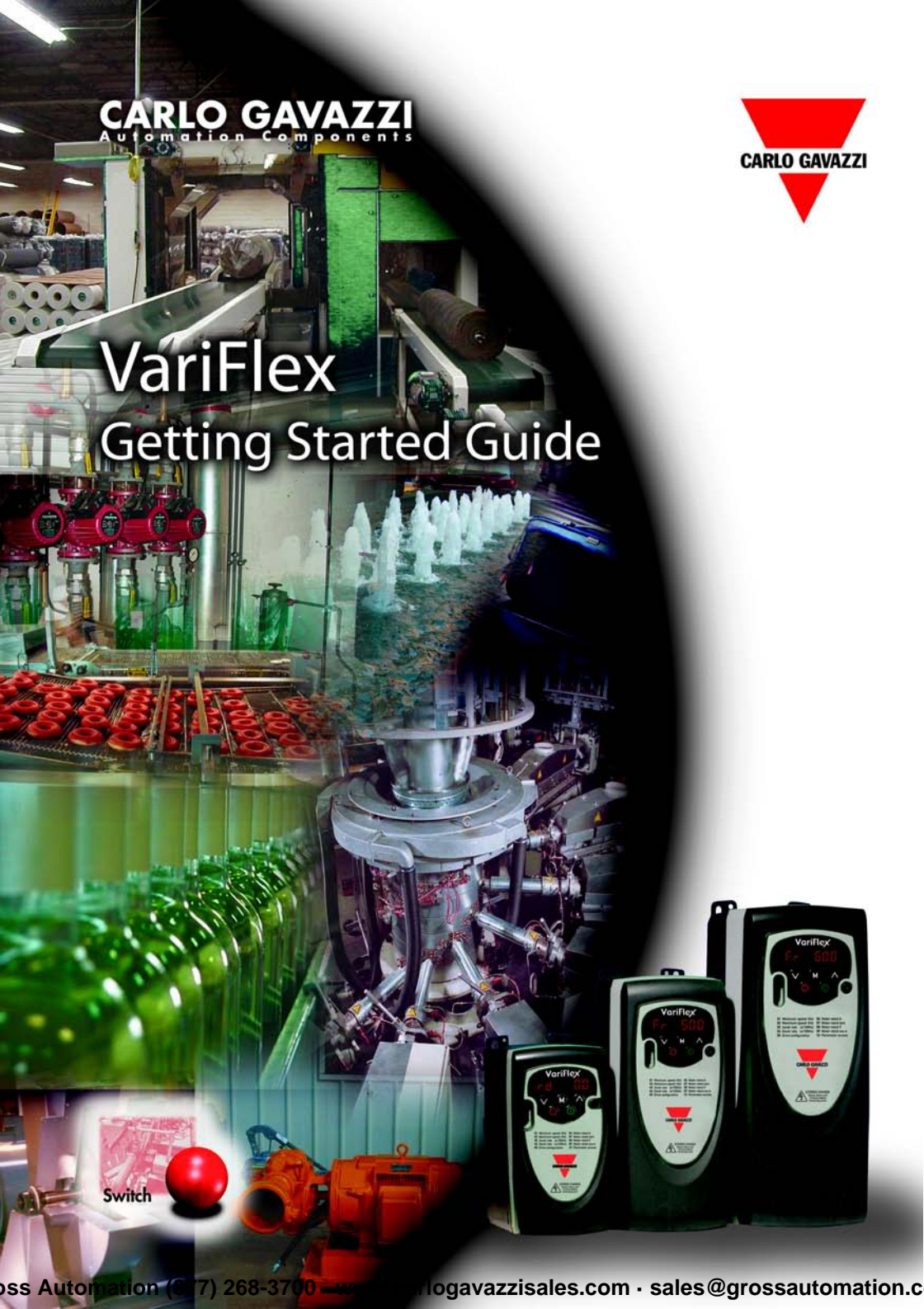

VariFlex

Getting Started Guide



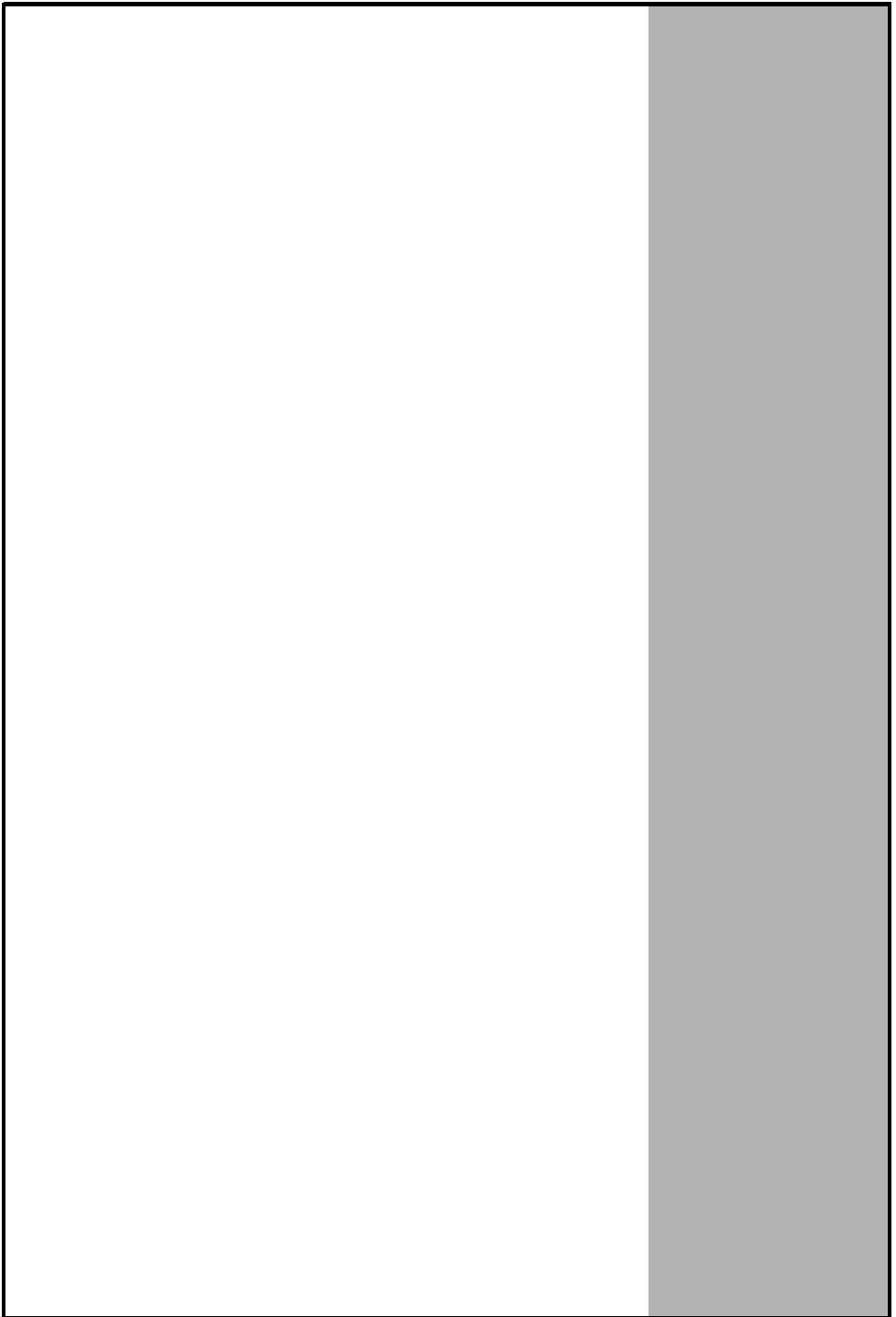

General Information

The manufacturer accepts no liability for any consequences resulting from inappropriate, negligent or incorrect installation or adjustment of the optional parameters of the equipment or from mismatching the variable speed drive with the motor.

The contents of this guide are believed to be correct at the time of printing. In the interests of commitment to a policy of continuous development and improvement, the manufacturer reserves the right to change the specification of the product or its performance, or the content of the guide without notice.

All rights reserved. No parts of this guide may be reproduced or transmitted in any form or by any means, electrical or mechanical including, photocopying, recording or by an information storage or retrieval system, without permission in writing from the publisher.

Drive software version

This product is supplied with the latest version of user-interface and machine control software. If this product is to be used in a new or existing system with other drives, there may be some differences between their software and the software in this product. These differences may cause the product to function differently. This may also apply to drives returned from the Carlo Gavazzi Service Centre. If there is any doubt, please contact your local Carlo Gavazzi representative or Distributor.

Environmental Statement

The electronic variable speed drives have the potential to save energy and (through increased machine/process efficiency) reduce raw material consumption and scrap throughout their long working lifetime. In typical applications, these positive environmental effects far outweigh the negative impacts of product manufacture and end-of-life disposal.

Nevertheless, when the products eventually reach the end of their useful life, they can very easily be dismantled into their major component parts for efficient recycling. Many parts snap together and can be separated without the use of tools, while other parts are secured with conventional screws. Virtually all parts of the product are suitable for recycling.

Product packaging is of good quality and can be re-used. Large products are packed in wooden crates, while smaller products come in strong cardboard cartons which themselves have a high-recycled fibre content. If not re-used, these containers can be recycled. Polythene, used on the protective film and bags from wrapping product, can be recycled in the same way. Carlo Gavazzi' packaging strategy favours easily recyclable materials of low environmental impact, and regular reviews identify opportunities for improvement.

When preparing to recycle or dispose of any product or packaging, please observe local legislation and best practice.

Copyright © April 2005

Issue: 3

Contents

	Declaration of Conformity	4
1	Safety Information	5
1.1	Warnings, Cautions and Notes	5
1.2	Electrical Safety - general warning	5
1.3	System design and safety of personnel	5
1.4	Environmental Limits	5
1.5	Access	6
1.6	Compliance and regulations	6
1.7	Motor	6
1.8	Adjusting parameters	6
1.9	Electrical installation	6
2	Rating Data	8
3	Mechanical Installation	9
4	Electrical Installation	11
4.1	Power terminal connections	11
4.2	Ground leakage	12
4.3	EMC	13
4.4	Control terminals I/O specification	14
5	Keypad and Display	17
5.1	Programming keys	17
5.2	Control keys	17
5.3	Selecting and changing parameters	18
5.4	Saving parameters	19
5.5	Parameter access	19
5.6	Security codes	19
5.7	Setting drive back to default values	20
6	Parameters	21
6.1	Parameter descriptions - Level 1	21
6.2	Parameter descriptions - Level 2	26
6.3	Parameter descriptions - Level 3	35
6.4	Diagnostic parameters	35
7	Quick Start Commissioning	36
7.1	Terminal control	36
7.2	Keypad control	38
8	Diagnostics	40
9	Options	42
9.1	Documentation	43
10	Parameter List	44
11	UL Listing Information	46
11.1	Common UL information (for SmartDrive size A and B)	46
11.2	Power dependant UL information	46

Declaration of Conformity

Carlo Gavazzi Ltd

RVFA120025	RVFA120037	RVFA120055	RVFA120075	
RVFBD20110	RVFBD20150			
RVFB340037	RVFB340055	RVFB340075	RVFB340110	RVFB340150
RVFCD20220				
RVFC340220	RVFC340300	RVFC340400		

The AC variable speed drive products listed above have been designed and manufactured in accordance with the following European harmonised standards:

EN 61800-5-1	Adjustable speed electrical power drive systems - safety requirements - electrical, thermal and energy
EN 61800-3	Adjustable speed electrical power drive systems. EMC product standard including specific test methods
EN 61000-6-2	Electromagnetic compatibility (EMC). Generic standards. Immunity standard for industrial environments
EN 61000-6-4	Electromagnetic compatibility (EMC). Generic standards. Emission standard for industrial environments
EN 61000-3-2	Electromagnetic compatibility (EMC), Limits, Limits for harmonic current emissions (equipment input current <16A per phase)
EN 61000-3-3	Electromagnetic compatibility (EMC), Limits, Limitation of voltage fluctuations and flicker in low-voltage supply systems for equipment with rated current <16A

These products comply with the Low Voltage Directive 73/23/EEC, the Electromagnetic Compatibility (EMC) Directive 89/336/EEC and the CE Marking Directive 93/68/EEC.

These electronic drive products are intended to be used with appropriate motors, controllers, electrical protection components and other equipment to form complete end products or systems. Compliance with safety and EMC regulations depends upon installing and configuring drives correctly, including using the specified input filters. The drives must be installed only by professional assemblers who are familiar with requirements for safety and EMC. The assembler is responsible for ensuring that the end product or system complies with all the relevant laws in the country where it is to be used. Refer to the *VariFlex Getting Started Guide*. An EMC Data Sheet is also available giving detailed EMC information.

1 Safety Information

1.1 Warnings, Cautions and Notes



A **Warning** contains information, which is essential for avoiding a safety hazard.



A **Caution** contains information, which is necessary for avoiding a risk of damage to the product or other equipment.

NOTE

A **Note** contains information, which helps to ensure correct operation of the product.

1.2 Electrical Safety - general warning

The voltages used in the drive can cause severe electrical shock and/or burns, and could be lethal. Extreme care is necessary at all times when working with or adjacent to the drive.

Specific warnings are given at the relevant places in this guide.

1.3 System design and safety of personnel

The drive is intended as a component for professional incorporation into complete equipment or system. If installed incorrectly, the drive may present a safety hazard.

The drive uses high voltages and currents, carries a high level of stored electrical energy, and is used to control equipment which can cause injury.

System design, installation, commissioning and maintenance must be carried out by personnel who have the necessary training and experience. They must read this safety information and this guide carefully.

The STOP and START controls or electrical inputs of the drive must not be relied upon to ensure safety of personnel. They do not isolate dangerous voltages from the output of the drive or from any external option unit. The supply must be disconnected by an approved electrical isolation device before gaining access to the electrical connections.

The drive is not intended to be used for safety-related functions.

Careful consideration must be given to the function of the drive which might result in a hazard, either through its intended behaviour or through incorrect operation due to a fault. In any application where a malfunction of the drive or its control system could lead to or allow damage, loss or injury, a risk analysis must be carried out, and where necessary, further measures taken to reduce the risk - for example, an over-speed protection device in case of failure of the speed control, or a fail-safe mechanical brake in case of loss of motor braking.

1.4 Environmental Limits

Instructions within the supplied data and information within the *VariFlex Technical Data Guide* regarding transport, storage, installation and the use of the drive must be complied with, including the specified environmental limits. Drives must not be subjected to excessive physical force.

1.5 Access

Access must be restricted to authorised personnel only. Safety regulations which apply at the place of use must be complied with.

The IP (Ingress Protection) rating of the drive is installation dependant. For further information, refer to the *VariFlex Technical Data Guide*.

1.6 Compliance and regulations

The installer is responsible for complying with all relevant regulations, such as national wiring regulations, accident prevention regulations and electromagnetic compatibility (EMC) regulations. Particular attention must be given to the cross-sectional areas of conductors, the selection of fuses and other protection, and protective earth (ground) connections.

The *VariFlex EMC Guide* contains instructions for achieving compliance with specific EMC standards.

Within the European Union, all machinery in which this product is used must comply with the following directives:

98/37/EC: Safety of machinery

89/336/EEC: Electromagnetic compatibility

1.7 Motor

Ensure the motor is installed in accordance with the manufacturer's recommendations. Ensure the motor shaft is not exposed.

Standard squirrel cage induction motors are designed for single speed operation. If it is intended to use the capability of a drive to run a motor at speeds above its designed maximum, it is strongly recommended that the manufacturer is consulted first.

Low speeds may cause the motor to overheat because the cooling fan becomes less effective. The motor should be fitted with a protection thermistor. If necessary, an electric force vent fan should be used.

The values of the motor parameters set in the drive affect the protection of the motor. The default values in the drive should not be relied upon.

It is essential that the correct value is entered into parameter **06**, motor rated current. This affects the thermal protection of the motor.

1.8 Adjusting parameters

Some parameters have a profound effect on the operation of the drive. They must not be altered without careful consideration of the impact on the controlled system.

Measures must be taken to prevent unwanted changes due to error or tampering.

1.9 Electrical installation

1.9.1 Electric shock risk

The voltages present in the following locations can cause severe electric shock and may be lethal:

- AC supply cables and connections
- DC bus, dynamic brake cables and connections
- Output cables and connections
- Many internal parts of the drive, and external option units

Unless otherwise indicated, control terminals are single insulated and must not be touched.

1.9.2 Isolation device

The AC supply must be disconnected from the drive using an approved isolation device before any cover is removed from the drive or before any servicing work is performed.

1.9.3 STOP function

The STOP function does not remove dangerous voltages from the drive, the motor or any external option units.

1.9.4 Stored charge

The drive contains capacitors that remain charged to a potentially lethal voltage after the AC supply has been disconnected. If the drive has been energised, the AC supply must be isolated at least ten minutes before work may continue.

Normally, the capacitors are discharged by an internal resistor. Under certain, unusual fault conditions, it is possible that the capacitors may fail to discharge, or be prevented from being discharged by a voltage applied to the output terminals. If the drive has failed in a manner that causes the display to go blank immediately, it is possible the capacitors will not be discharged. In this case, consult Carlo Gavazzi or their authorised distributor.

1.9.5 Equipment supplied by plug and socket

Special attention must be given if the drive is installed in equipment which is connected to the AC supply by a plug and socket. The AC supply terminals of the drive are connected to the internal capacitors through rectifier diodes which are not intended to give safety isolation. If the plug terminals can be touched when the plug is disconnected from the socket, a means of automatically isolating the plug from the drive must be used (e.g. a latching relay).

1.9.6 Ground leakage current

The drive is supplied with an internal EMC filter capacitor fitted. If the input voltage to the drive is supplied through an ELCB or RCD, these may trip due to the ground leakage current. See section 4.3.1 *Internal EMC filter* on page 13 for further information and how to disconnect the internal EMC capacitor.

2 Rating Data

Figure 2-1 Model code explanation

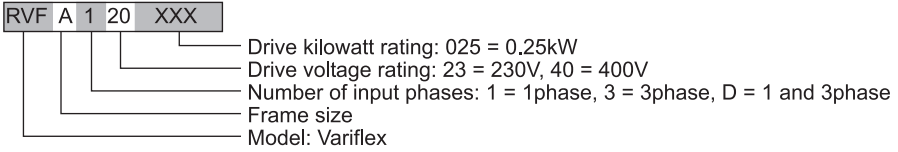

Table 2-1 VariFlex 200V units

Model Number	Nominal motor power		Supply voltage and frequency	Typical full load input current		Maximum continuous input current		100% RMS output current	150% overload current for 60s	Minimum braking resistor value Ω	
	kW	hp		1ph	3ph	1ph	3ph	Heavy Duty			
								A	A		
RVFA120025	0.25	0.33	1 phase 200 to 240Vac ±10% 48 to 62Hz	4.3				1.7	2.55	68	
RVFA120037	0.37	0.5		5.8				2.2	3.3	68	
RVFA120055	0.55	0.75		8.1				3.0	4.5	68	
RVFA120075	0.75	1.0		10.5				4.0	6.0	68	
RVFBD20110	1.1	1.5	1/3 phase 200 to 240Vac ±10% 48 to 62Hz	14.2	6.7			9.2	5.2	7.8	28
RVFBD20150	1.5	2.0		17.4	8.7			12.6	7.0	10.5	28
RVFCD20220	2.2	3.0		23.2	11.9			17.0	9.6	14.4	28

Table 2-2 VariFlex 400V units

Model Number	Nominal motor power		Supply voltage and frequency	Typical full load input current	Maximum continuous input current	100% RMS output current		150% overload current for 60s		Minimum braking resistor value Ω
	kW	hp				A	A	Heavy Duty		
								A	A	
RVFB340037	0.37	0.5	3 phase 380 to 480Vac ±10% 48 to 62Hz	1.7	2.5	1.3	1.95	100		
RVFB340055	0.55	0.75		2.5	3.1	1.7	2.55	100		
RVFB340075	0.75	1.0		3.1	3.75	2.1	3.15	100		
RVFB340110	1.1	1.5		4.0	4.6	2.8	4.2	100		
RVFB340150	1.5	2.0		5.2	5.9	3.8	5.7	100		
RVFC340220	2.2	3.0		7.3	9.6	5.1	7.65	100		
RVFC340300	3.0	3.0		9.5	11.2	7.2	10.8	55		
RVFC340400	4.0	5.0		11.9	13.4	9.0	13.5	55		

Output frequency: 0 to 1500Hz

Output voltage: 3 phase, 0 to drive rating (240 or 480Vac maximum set by Pr 08).

NOTE The output voltage can be increased by 20% during deceleration. See Pr 30 on page 29

NOTE The maximum continuous current inputs are used to calculate input cable and fuse sizing. Where no maximum continuous input currents are indicated, use the typical full load input current values. See *VariFlex Technical Data Guide* for cable and fuse data.

3 Mechanical Installation

Enclosure
 The drive is intended to be mounted in an enclosure which prevents access except by trained and authorised personnel, and which prevents the ingress of contamination. It is designed for use in an environment classified as pollution degree 2 in accordance with IEC 60664-1. This means that only dry, non-conducting contamination is acceptable.



Figure 3-1 VariFlex dimensions

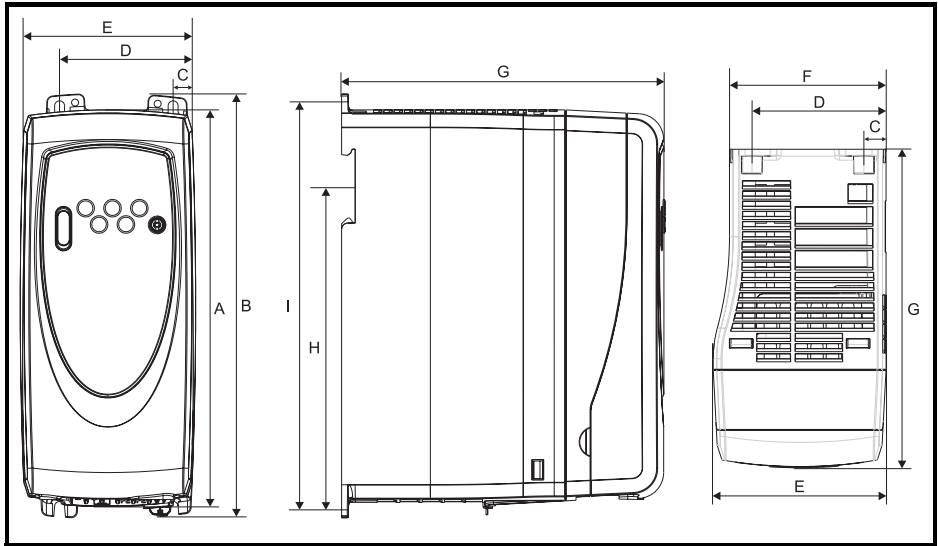

Mounting holes: 4 x M4 holes

Table 3-1 VariFlex dimensions

Drive size	A		B		C		D		E		F		G		H*		I	
	mm	in	mm	in	mm	in	mm	in	mm	in	mm	in	mm	in	mm	in	mm	in
A	140	5.51	154	6.06	11	0.43	64	2.52	75	2.95			145	5.71	104	4.09	143	5.63
B	190	7.48	205	8.07	10.9	0.43	65.9	2.6	85	3.35	77	3.0	156	6.15	155.5	6.12	194	7.64
C	240	9.45	258	10.16	10.4	0.41	81.1	3.2	100	3.94	91.9	3.62	173	6.81			244	9.61

*Size C is not DIN rail mountable.

NOTE If DIN rail mounting is used in an installation where the drive is to be subjected to shock or vibration, it is recommended that the bottom mounting screws are used to secure the drive to the back plate.

If the installation is going to be subjected to heavy shock and vibration, then it is recommended that the drive is surface mounted rather than DIN rail mounted.

NOTE The DIN rail mounting mechanism has been designed so no tools are required to install and remove the drive from a DIN rail. Please ensure the top mounting lugs are located correctly on the DIN rail before installation is initiated.

Figure 3-2 Minimum mounting clearances

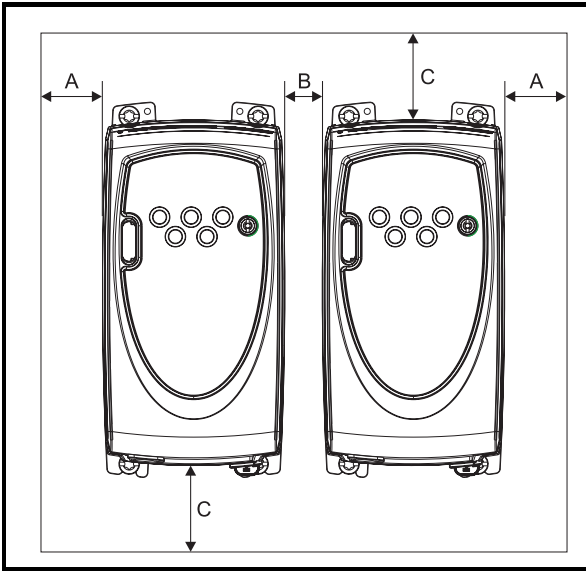

Drive size	A		B		C	
	mm	in	mm	in	mm	in
A			0	0		
B ($\leq 0.75\text{kW}$)	10	0.39	10	0.39	100	3.94
B ($\geq 1.1\text{kW}$)			0	0		
C						

Figure 3-3 Features of the drive (size B illustrated)

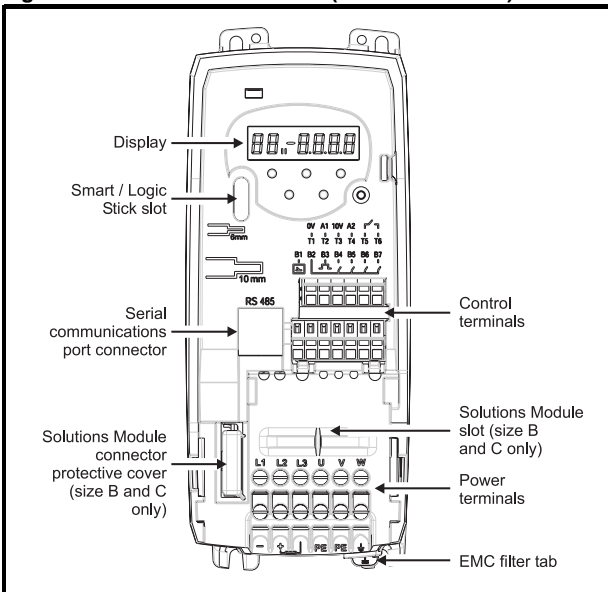

4 Electrical Installation

4.1 Power terminal connections

Figure 4-1 Size A power terminal connections

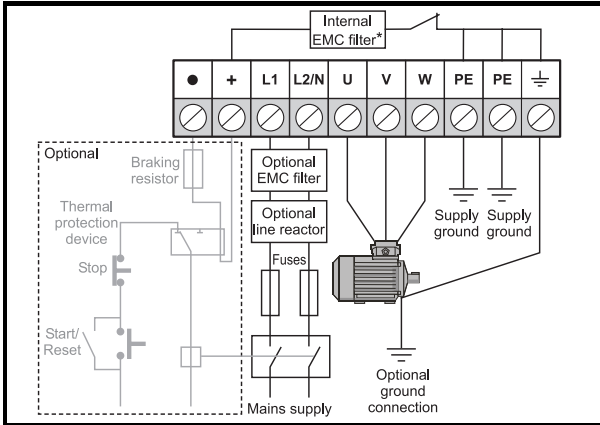
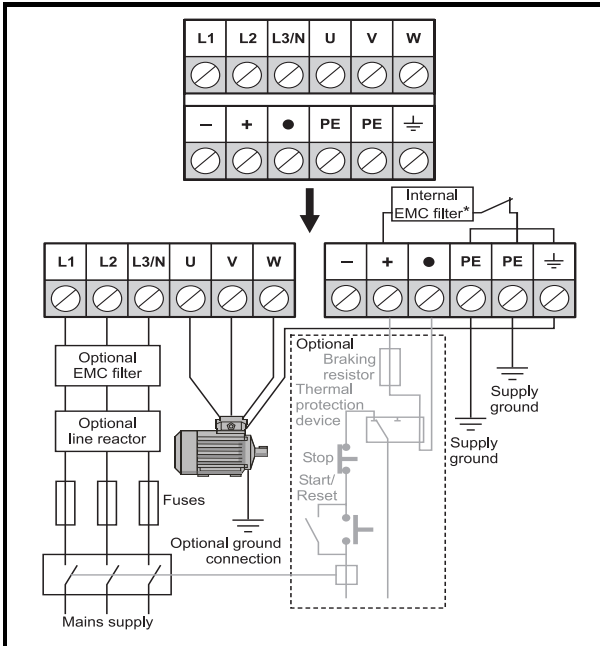



Figure 4-2 Sizes B and C power terminal connections



*For further information, see section 4.3.1 *Internal EMC filter* on page 13.



WARNING

Fuses/MCB

The AC supply to the drive must be fitted with suitable protection against overload and short circuits. Failure to observe this requirement will cause risk of fire. See the *VariFlex Technical Data Guide* for fuse data.

Safety Information
Rating Data
Mechanical Installation
Electrical Installation
Keypad and Display
Parameters
Quick Start Commissioning
Diagnostics
Options
Parameter List
UL Listing Information



The drive must be grounded by a conductor sufficient to carry the prospective fault current in the event of a fault. See also the warning in section 4.2 *Ground leakage* relating to ground leakage current.



To avoid a fire hazard and maintain validity of the UL listing, adhere to the specified tightening torques for the power and ground terminals. Refer to the table below.

Frame size	Maximum power terminal screw torque
A	0.5 N m / 4.4 lb in
B and C	1.4 N m / 12.1 lb in



Braking resistor: High temperatures and overload protection

Braking resistors can reach high temperatures. Locate braking resistors so that damage cannot result. Use cable having insulation capable of withstanding the high temperatures.

It is essential that the braking resistor be protected against overload caused by a failure of the brake control. Unless the resistor has in-built protection, a circuit like those shown in Figure 4-1 and Figure 4-2 should be used, where the thermal protection device disconnects the AC supply to the drive. Do not use AC relay contacts directly in series with the braking resistor circuit, because it carries DC.

NOTE When connecting single phase to a dual rated 200V unit, use terminals L1 and L3.

NOTE For control terminal connections, see Pr **05** on page 22.

NOTE For information on the internal EMC filter, see section 4.3.1 *Internal EMC filter* .

4.2 Ground leakage

The ground leakage current depends upon the internal EMC filter being fitted. The drive is supplied with the filter fitted. Instructions for removal of the internal EMC filter are given in section 4.3.2 *Removing the internal EMC filter* .

With internal EMC filter fitted

30 μ A DC (10M Ω internal bleed resistor, relevant where DC leakage current is being measured)

Size A

10mA AC at 230V, 50Hz (proportional to supply voltage and frequency)

Size B and C

1 phase 200V drives

20mA AC at 230V, 50Hz (proportional to supply voltage and frequency)

3 phase 200V drives

8mA AC at 230V, 50Hz (proportional to supply voltage and frequency)

3 phase 400V drives

8.2mA AC at 415V, 50Hz (proportional to supply voltage and frequency)

NOTE The above leakage currents are just the leakage currents of the drive with the internal EMC filter connected and do not take into account any leakage currents of the motor or motor cable.

With internal EMC filter removed

<1mA

NOTE In both cases, there is an internal voltage surge suppression device connected to ground. Under normal circumstances, this carries negligible current.



When the internal EMC filter is fitted, the leakage current is high. In this case, a permanent fixed ground connection must be provided using two independent conductors each with a cross-section equal to or exceeding that of the supply conductors. The drive is provided with two ground terminals to facilitate this. The purpose is to prevent a safety hazard occurring if a connection is lost.

4.2.1 Use of earth (ground) leakage circuit breakers (ELCB) / residual current device (RCD)

There are three common types of ELCB/RCD:

Type AC - detects AC fault currents

Type A - detects AC and pulsating DC fault currents (provided the DC current reaches zero at least once every half cycle)

Type B - detects AC, pulsating DC and smooth DC fault currents

- Type AC should never be used with drives
- Type A can only be used with single phase drives
- Type B must be used with three phase drives

4.3 EMC

4.3.1 Internal EMC filter

It is recommended that the internal EMC filter is kept in place unless there is a specific reason for removing it.

If the drive is to be used on an IT supply, then the filter must be removed.

The internal EMC filter reduces radio-frequency emissions into the mains supply. Where the motor cable is short, it permits the requirements of EN61800-3 to be met for the second environment.

For longer motor cables, the filter continues to provide a useful reduction in emission level, and when used with any length of shielded cable up to the limit for the drive, it is unlikely that nearby industrial equipment will be disturbed. It is recommended that the filter be used in all applications unless the ground leakage current is unacceptable or the above conditions are true.

4.3.2 Removing the internal EMC filter

Figure 4-3 Removal and re-fitting of internal EMC filter

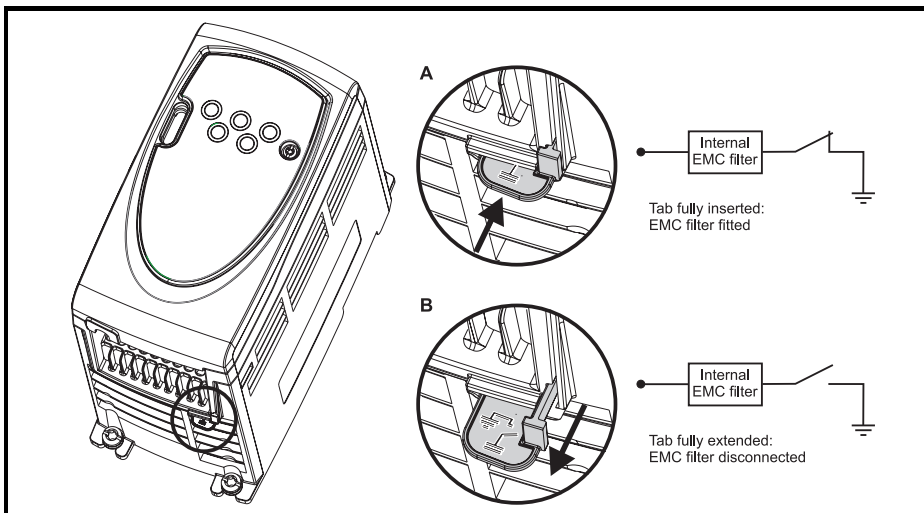

4.3.3 Further EMC precautions

Further EMC precautions are required if more stringent EMC emission requirements apply:

- Operation in the first environment of EN 61800-3
- Conformity to the generic emission standards
- Equipment which is sensitive to electrical interference operating nearby

In this case it is necessary to use:

- The optional external EMC filter
- A screened motor cable, with screen clamped to the grounded metal panel
- A screened control cable, with screen clamped to the grounded metal panel

Full instructions are given in the *VariFlex EMC Guide*.

A full range of external EMC filters is also available for use with VariFlex.

4.4 Control terminals I/O specification



The control circuits are isolated from the power circuits in the drive by basic insulation (single insulation) only. The installer must ensure that the external control circuits are insulated from human contact by at least one layer of insulation (supplementary insulation) rated for use at the AC supply voltage.



If the control circuits are to be connected to other circuits classified as Safety Extra Low Voltage (SELV) (e.g. to personal computer), an additional isolating barrier must be included in order to maintain the SELV classification.



The above warnings also apply to the PCB edge connector for the optional Solutions Modules. To allow a Solutions Module to be fitted to VariFlex, a protective cover must be removed to allow access to the PCB edge connector. See Figure 3-3 on page 10. This protective cover provides protection from direct contact of the PCB edge connector by the user. When this cover is removed and a Solutions Module fitted, the Solutions Module provides the protection from direct contact by the user. If the Solutions Module is then removed, this PCB edge connector becomes exposed. The user is required to provide protection in this case, to protect against direct contact of this PCB edge connector.

NOTE See Pr **05** on page 22 (*Drive configuration*) for terminal connection / set-up diagrams and details.

NOTE The digital inputs are positive logic only.

NOTE The analog inputs are unipolar. For information on a bipolar input, see the VariFlex *Advanced User Guide*.

T1 0V common

T2 Analog input 1 (A1), either voltage or current (see Pr 16)

Voltage: Current input	0 to 10V: mA as parameter range
Parameter range	4-20, 20-4, 0-20, 20-0, 4-.20, 20-.4, VoLt
Scaling	Input range automatically scaled to Pr 01 <i>Minimum set speed</i> / Pr 02 <i>Maximum set speed</i>
Input impedance	200Ω (current): 100kΩ (voltage)
Resolution	0.1%

- 0-20:** Current input 0 to 20mA (20mA full scale)
- 20-0:** Current input 20 to 0mA (0mA full scale)
- 4-20:** Current input 4 to 20mA with current loop loss (cL1) trip (20mA full scale)
- 20-4:** Current input 20 to 4mA with current loop loss (cL1) trip (4mA full scale)
- 4-20:** Current input 4 to 20mA with no current loop loss (cL1) trip (20mA full scale)
- 20-4:** Current input 20 to 4mA with no current loop loss (cL1) trip (4mA full scale)
- VolT:** 0 to 10V input

T3 +10V reference output	
Maximum output current	5mA

T4 Analog input 2 (A2), either voltage or digital input	
Voltage: Digital input	0 to +10V: 0 to +24V
Scaling (as voltage input)	Input range automatically scaled to Pr 01 <i>Minimum set speed</i> / Pr 02 <i>Maximum set speed</i>
Resolution	0.1%
Input impedance	100kΩ (voltage): 6k8 (digital input)
Normal threshold voltage (as digital input)	+10V (positive logic only)

T5 Status relay - Drive healthy (Normally open)	
T6	
Voltage rating	240Vac/30Vdc
Current rating	2A/6A (resistive)
Contact isolation	1.5kVac (over voltage category II)
Operation of contact	OPEN AC supply removed from drive AC supply applied to drive with drive in tripped condition CLOSED AC supply applied to drive with drive in a 'ready to run' or 'running' condition (not tripped)



Provide fuse or other over-current protection in status relay circuit.

B1 Analog voltage output - Motor speed	
Voltage output	0 to +10V
Scaling	0V represents 0Hz/rpm output +10V represents the value in Pr 02 <i>Maximum set speed</i>
Maximum output current	5mA
Resolution	0.1%

B2 +24V output	
Maximum output current	100mA

B3 Digital output - Zero speed	
Voltage range	0 to +24V
Maximum output current	50mA at +24V (current source)

Safety Information
Rating Data
Mechanical Installation
Electrical Installation
Keypad and Display
Parameters
Quick Start Commissioning
Diagnostics
Options
Parameter List
UL Listing Information

NOTE

The total available current from the digital output plus the +24V output is 100mA.

B4	Digital Input - Enable/Reset*/**
B5	Digital Input - Run Forward**
B6	Digital Input - Run Reverse**
B7	Digital Input - Local/Remote speed reference select (A1/A2)
Logic	Positive logic only
Voltage range	0 to +24V
Nominal threshold voltage	+10V

If the enable terminal is opened, the drive's output is disabled and the motor will coast to a stop. The drive will not re-enable for 1.0s after the enable terminal is closed again.

*Following a drive trip, opening and closing the enable terminal will reset the drive. If the run forward or run reverse terminal is closed, the drive will run straight away.

**Following a drive trip and a reset via the stop/reset key, the enable, run forward or run reverse terminals will need to be opened and closed to allow the drive to run. This ensures that the drive does not run when the stop/reset key is pressed.

The enable, run forward and run reverse terminals are level triggered apart from after a trip where they become edge triggered. See * and ** above.

If the enable and run forward or enable and run reverse terminals are closed when the drive is powered up, the drive will run straight away up to a set speed.

If both the run forward and run reverse terminals are closed, the drive will stop under the control of the ramp and stopping modes set in Pr 30 and Pr 31.

5 Keypad and Display

The keypad and display are used for the following:

- Displaying the operating status of the drive
- Displaying a fault or trip code
- Reading and changing parameter values
- Stopping, starting and resetting the drive

Figure 5-1 Keypad and display

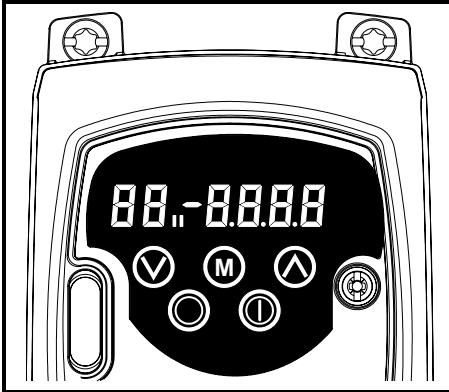

5.1 Programming keys

The **MODE** key is used to change the mode of operation of the drive.

The **UP** and **DOWN** keys are used to select parameters and edit their values. In keypad mode, they are used to increase and decrease the speed of the motor.

5.2 Control keys

The **START** key is used to start the drive in keypad mode.

The **STOP/RESET** key is used to stop and reset the drive in keypad mode. It can also be used to reset the drive in terminal mode.

NOTE

It is possible to change parameter values more quickly. See Chapter 4 *Keypad and display* in the *VariFlex Advanced User Guide* for details.

Safety Information
Rating Data
Mechanical Installation
Electrical Installation
Keypad and Display
Parameters
Quick Start Commissioning
Diagnostics
Options
Parameter List
UL Listing Information

5.3 Selecting and changing parameters

NOTE

This procedure is written from the first power up of the drive and assumes no terminals have been connected, no parameters have been changed and no security has been set.

Figure 5-2

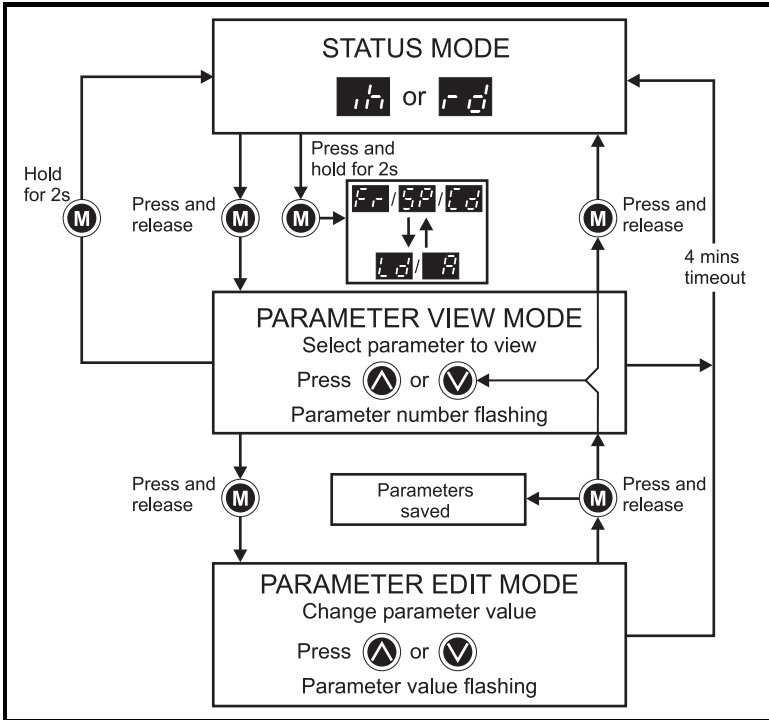





When in Status mode, pressing and holding the **M** MODE key for 2 seconds will change the display from displaying a speed indication to displaying load indication and vice versa.

Pressing and releasing the **M** MODE key will change the display from status mode to parameter view mode. In parameter view mode, the left hand display flashes the parameter number and the right hand display shows the value of that parameter.



Pressing and releasing the **M** MODE key again will change the display from parameter view mode to parameter edit mode. In parameter edit mode, the right hand display flashes the value in the parameter being shown in the left hand display.

Pressing the **M** MODE key in parameter edit mode will return the drive to the parameter view mode. If the **M** MODE key is pressed again then the drive will return to status mode, but if either of the **▲** up or **▼** down keys are pressed to change the parameter being viewed before the **M** MODE key is pressed, pressing the **M** MODE key will change the display to the parameter edit mode again. This allows the user to very easily change between parameter view and edit modes whilst commissioning the drive.



Status Modes

Left hand display	Status	Explanation
	Drive ready	The drive is enabled and ready for a start command. The output bridge is inactive.
	Drive inhibited	The drive is inhibited because there is no enable command, or a coast to stop is in progress or the drive is inhibited during a trip reset.
	Drive has tripped	The drive has tripped. The trip code will be displayed in the right hand display.
	DC injection braking	DC injection braking current is being applied to the motor.

Speed Indications

Display Mnemonic	Explanation
	Drive output frequency in Hz
	Motor speed in rpm
	Machine speed in customer define units

Load indications

Display Mnemonic	Explanation
	Load current as a % of motor rated load current
	Drive output current per phase in A

5.4 Saving parameters

Parameters are automatically saved when the  MODE key is pressed when going from parameter edit mode to parameter view mode.

5.5 Parameter access

There are 3 levels of parameter access controlled by Pr **10**. This determines which parameters are accessible. See Table 5-1.

The setting of the user security Pr **25** determines whether the parameter access is read only (RO) or read write (RW).

Table 5-1

Parameter access (Pr 10)	Parameters accessible
L1	Pr 01 to Pr 10
L2	Pr 01 to Pr 60
L3	Pr 01 to Pr 95

5.6 Security codes

Setting a security code allows view only access to all parameters.



A security code is locked into the drive when Pr **25** is set to any other value than 0 and then **LoC** is selected in Pr **10**. On pressing the  MODE key, Pr **10** is automatically changed from **LoC** to **L1** and Pr **25** will be automatically set to 0 so as not to reveal the security code.

Pr **10** may be changed to L2 or L3 to allow view only access to parameters.

5.6.1 Setting a security code

- Set Pr **10** to L2.
- Set Pr **25** to the desired security code e.g. 5
- Set Pr **10** to LoC.
- Press the  MODE key
- Pr **10** will now be reset to L1 and Pr **25** will be reset to 0.
- The security code will now be locked into the drive.
- Security will also be set if the drive is powered down after a security code has been set into Pr **25**.

5.6.2 Unlocking a security code

- Select parameter to be edited
- Press the  MODE key, the right hand display will flash 'CodE'
- Press the  UP key to start entering the set security code. The left hand display will show 'Co'
- Enter the correct security code
- Press the  MODE key
- If the correct security code has been entered, the right hand display will flash and can now be adjusted.
- If the security code has been entered incorrectly, the left hand display will flash the parameter number. The above procedure should be followed again.

5.6.3 Re-locking security

When a security code has been unlocked and the required parameter changes made, to re-lock the same security code:

- Set Pr **10** to LoC
- Press the  MODE key

5.6.4 Setting security back to 0 (zero) - no security

- Set Pr **10** to L2
- Go to Pr **25**
- Unlock security as described above.
- Set Pr **25** to 0
- Press the  MODE key.

NOTE

If a security code has been lost or forgotten, please contact your local drive centre or distributor

5.7 Setting drive back to default values

- Set Pr **10** to L2
- Set Pr **29** to EUR and press the  MODE key. This loads 50Hz default parameters.

or

- Set Pr **29** to USA and press the  MODE key. This loads 60Hz default parameters.

6 Parameters

Parameters are grouped together into appropriate subsets as follows:

Level 1

Pr 01 to Pr 10: Basic drive set-up parameters

Level 2

Pr 11 to Pr 12: Drive operation set-up parameters

Pr 15 to Pr 21: Reference parameters

Pr 22 to Pr 29: Display / keypad configuration

Pr 30 to Pr 33: System configuration

Pr 34 to Pr 36: Drive user I/O configuration

Pr 37 to Pr 42: Motor configuration (non-standard set-up)

Pr 43 to Pr 44: Serial communications configuration

Pr 45: Drive software version

Pr 46 to Pr 51: Mechanical brake configuration

Pr 52 to Pr 54: Fieldbus configuration

Pr 55 to Pr 58: Drive trip log

Pr 59 to Pr 60: PLC ladder programming configuration

Pr 61 to Pr 70: User definable parameter area

Level 3

Pr 71 to Pr 80: User definable parameter set-up

Pr 81 to Pr 95: Drive diagnostics parameters

These parameters can be used to optimise the set-up of the drive for the application.

6.1 Parameter descriptions - Level 1

No	Function	Range	Defaults	Type
01	Minimum set speed	0 to Pr 02 Hz	0.0	RW

Used to set the minimum speed at which the motor will run in both directions.
(0V reference or minimum scale current input represents the value in Pr 01)

No	Function	Range	Defaults	Type
02	Maximum set speed	0 to 1500 Hz	EUR: 50.0, USA: 60.0	RW

Used to set the maximum speed at which the motor will run in both directions.

If Pr 02 is set below Pr 01, Pr 01 will be automatically set to the value of Pr 02. (+10V reference or full scale current input represents the value in Pr 02)

NOTE

The output speed of the drive can exceed the value set in Pr 02 due to slip compensation and current limits.

No	Function	Range	Defaults	Type
03	Acceleration rate	0 to 3200.0 s/100Hz	5.0	RW
04	Deceleration rate		10.0	

Sets the acceleration and deceleration rate of the motor in both directions in seconds/100Hz.

NOTE

If one of the standard ramp modes is selected (see Pr 30 on page 29), the deceleration rate could be extended automatically by the drive to prevent over voltage (OU) trips if the load inertia is too high for the programmed deceleration rate.

No	Function	Range	Defaults	Type
05	Drive configuration	AI.AV, AV.Pr, AI.Pr, Pr, PAd, E.Pot, tor, Pid, HUAC	AI.AV	RW

The setting of Pr **05** automatically sets up the drives configuration.

NOTE A change to Pr **05** is set by pressing the **MODE** key on exit from parameter edit mode. The drive must be disabled, stopped or tripped for a change to take place. If Pr **05** is changed while the drive is running, when the **MODE** key is pressed on exit from parameter edit mode, Pr **05** will change back to its previous value.

In all of the settings below, the status relay is set up as a drive healthy relay:

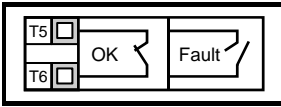

Configuration	Description
AI.AV	Voltage and current input
AV.Pr	Voltage input and 3 preset speeds
AI.Pr	Current input and 3 preset speeds
Pr	4 preset speeds
PAd	Keypad control
E.Pot	Electronic motorised potentiometer control
tor	Torque control operation
Pid	PID control
HUAC	Fan and pump control

Figure 6-1 Pr 05 = AI.AV

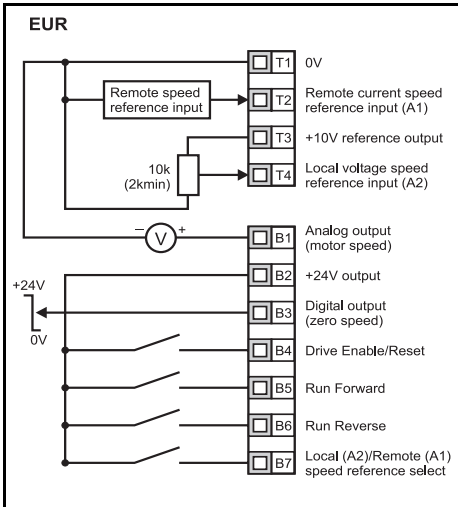

Terminal B7 open: Local voltage speed reference (A2) selected

Terminal B7 closed: Remote current speed reference (A1) selected

Figure 6-2 Pr 05 = AV.Pr

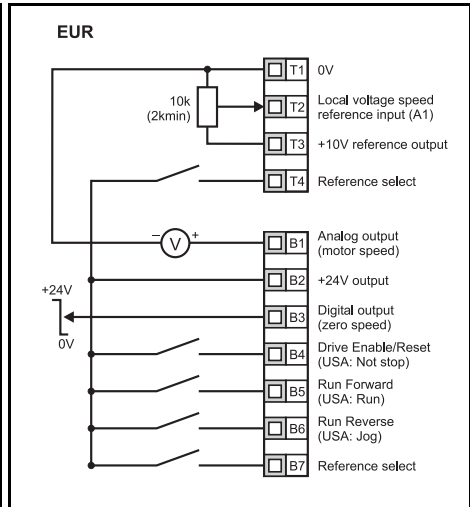

T4	B7	Reference selected
0	0	A1
0	1	Preset 2
1	0	Preset 3
1	1	Preset 4

Figure 6-3 Pr 05 = AI.Pr

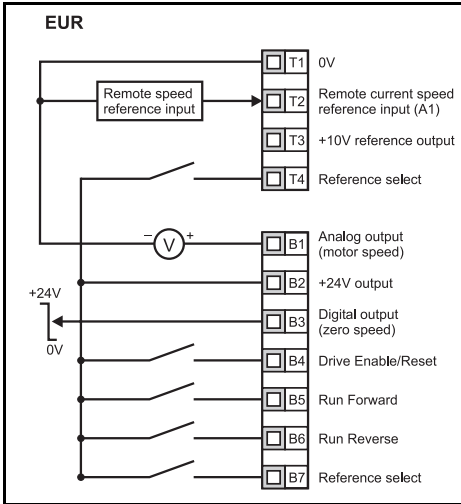

T4	B7	Reference selected
0	0	A1
0	1	Preset 2
1	0	Preset 3
1	1	Preset 4

Figure 6-4 Pr 05 = Pr

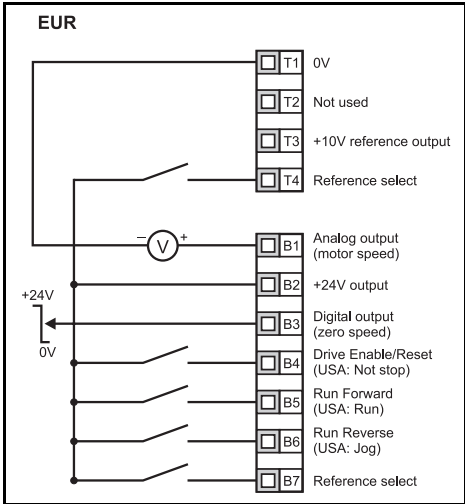

T4	B7	Reference selected
0	0	Preset 1
0	1	Preset 2
1	0	Preset 3
1	1	Preset 4

Figure 6-5 Pr 05 = PAd

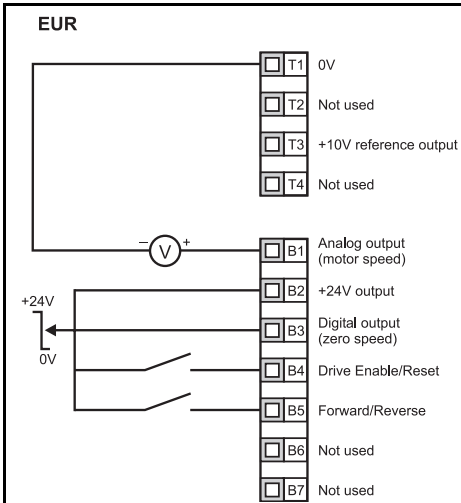
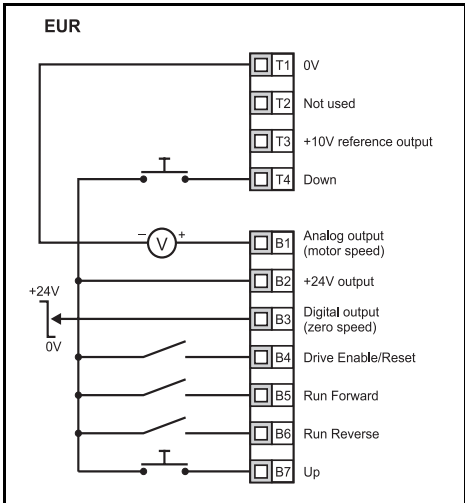

Figure 6-6 Pr 05 = E.Pot



When Pr 05 is set to PAd to implement a forward/reverse switch, see the VariFlex *Advanced User Guide*.

When Pr 05 is set to E.Pot, the following parameters are made available for adjustment:

- Pr 61: Motorised pot up/down rate (s/100%)
- Pr 62: Motorised pot bipolar select (0 = unipolar, 1 = bipolar)

- Pr 63: Motorised pot mode: 0 = zero at power-up, 1 = last value at power-up, 2 = zero at power-up and only change when drive is running, 3 = last value at power-up and only change when drive is running.

Figure 6-7 Pr 05 = tor

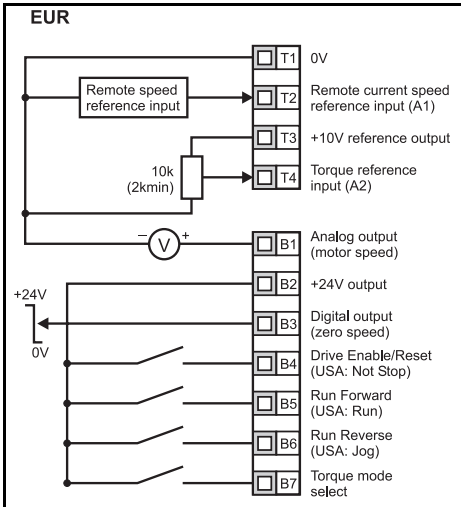
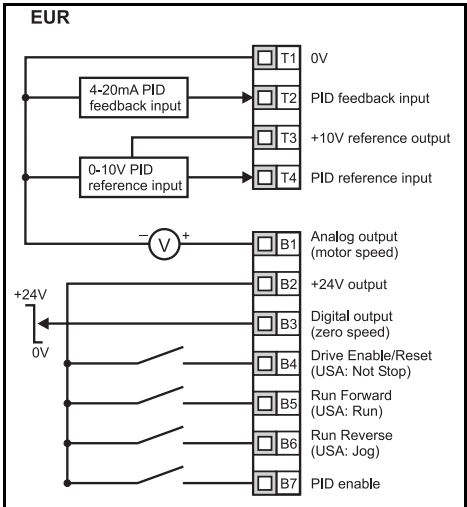

Figure 6-8 Pr 05 = Pid



When torque mode is selected and the drive is connected to an unloaded motor, the motor speed may increase rapidly to the maximum speed (Pr 02 +20%)

When Pr 05 is set to Pid, the following parameters are made available for adjustment:

- Pr 61: PID proportional gain
- Pr 62: PID integral gain
- Pr 63: PID feedback invert
- Pr 64: PID high limit (%)
- Pr 65: PID low limit (%)
- Pr 66: PID output (%)

Figure 6-9 PID logic diagram

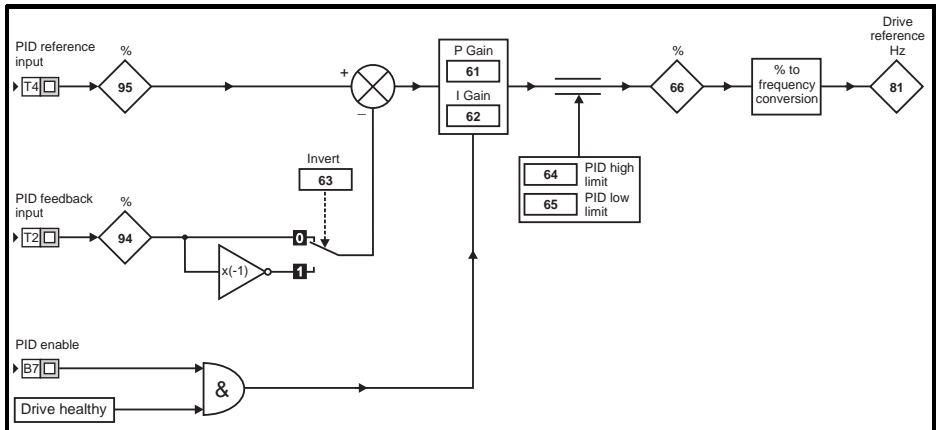
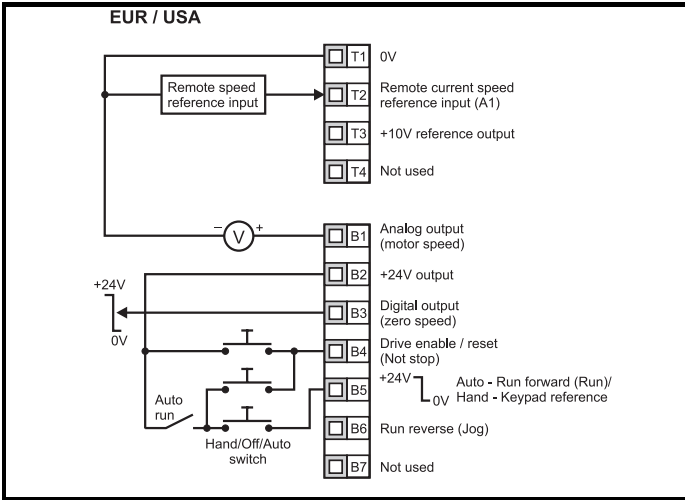



Figure 6-10 Pr 05 = HUAC terminal configuration



No	Function	Range	Defaults	Type
06	Motor rated current	0 to Drive rated current A	Drive rating	RW

Enter the motor current rating (taken from the motor name plate).

The drive rated current is the 100% RMS output current value of the drive. This value can be set to a lower value but not to a higher value than the drive rated current.

 **Pr 06 Motor rated current** must be set correctly to avoid a risk of fire in the event of a motor overload.

No	Function	Range	Defaults	Type
07	Motor rated speed	0 to 9999 rpm	EUR: 1500, USA: 1800	RW

Enter the rated full load speed of the motor (taken from the motor name plate).

The motor rated speed is used to calculate the correct slip speed for the motor.

- NOTE** A value of zero entered into Pr 07 means slip compensation is disabled.
- NOTE** If the full load speed of the motor is above 9999rpm, enter a value of 0 in Pr 07. This will disable slip compensation as values >9999 cannot be entered into this parameter.

No	Function	Range	Defaults	Type
08	Motor rated voltage	0 to 240, 0 to 480 V	EUR: 230 / 400 USA: 230 / 460	RW

Enter the motor rated voltage (taken from the motor name plate).

This is the voltage applied to the motor at base frequency.

- NOTE** If the motor is not a standard 50 or 60Hz motor, see Pr 39 on page 31 and adjust accordingly.

No	Function	Range	Defaults	Type
09	Motor power factor	0 to 1	0.85	RW

Enter the motor rated power factor $\cos \varphi$ (taken from the motor name plate).

- NOTE** The power factor value could be automatically changed after a rotating autotune. See Pr 38 on page 31.

Safety Information
Rating Data
Mechanical Installation
Electrical Installation
Keypad and Display
Parameters
Quick Start Commissioning
Diagnostics
Options
Parameter List
UL Listing Information

No	Function	Range	Defaults	Type
10	Parameter access	L1, L2, L3, LoC	L1	RW



L1: Level 1 access - only the first 10 parameters can be accessed
L2: Level 2 access - All parameters from 01 to 60 can be accessed
L3: Level 3 access - All parameters from 01 to 95 can be accessed
LoC: Used to lock a security code in the drive. See section 5.6 *Security codes* on page 19 for further details.

6.2 Parameter descriptions - Level 2

No	Function	Range	Defaults	Type
11	Start/Stop logic select	0 to 6	EUR: 0, USA: 4	RW

Pr 11	Terminal B4	Terminal B5	Terminal B6	Latching
0	Enable	Run Forward	Run Reverse	No
1	Not Stop	Run Forward	Run Reverse	Yes
2	Enable	Run	Forward / Reverse	No
3	Not Stop	Run	Forward / Reverse	Yes
4	Not Stop	Run	Jog	Yes
5	User programmable	Run Forward	Run Reverse	No
6	User Programmable	User Programmable	User Programmable	User Programmable



NOTE

A change to Pr 11 is set by pressing the  MODE key on exit from parameter edit mode. The drive must be disabled, stopped or tripped for a change to take place. If Pr 11 is changed while the drive is running, when the  MODE key is pressed on exit from parameter edit mode, Pr 11 will change back to its previous value.

No	Function	Range	Defaults	Type
12	Brake controller enable	diS, rEL, d IO, USEr	diS	RW

diS: Mechanical brake software disabled
rEL: Mechanical brake software enabled. Brake control via relay T5 & T6. The digital output on terminal B3 is automatically programmed as a drive healthy output.
d IO: Mechanical brake software enabled. Brake control via digital output B3. The relay outputs on terminals T5 and T6 are automatically programmed as a drive healthy output.
USEr: Mechanical brake software enabled. Brake control to be programmed by user. The relay and digital output are not programmed. The user should programme the brake control to either the digital output or relay. The output not programmed to the brake control can be programmed to indicate the required signal. (See *VariFlex Advanced User Guide*.)

NOTE

A change to Pr 12 is set by pressing the  MODE key on exit from parameter edit mode. The drive must be disabled, stopped or tripped for a change to take place. If Pr 12 is changed while the drive is running, when the  MODE key is pressed on exit from parameter edit mode, Pr 12 will change back to its previous value.

See Pr 46 to Pr 51 on page 32.



Great care should be taken when implementing a brake control set-up, as this may cause a safety issue depending on the application, e.g. crane. If in doubt, contact the supplier of the drive for further information.

No	Function	Range	Defaults	Type
13	Not used			
14				

No	Function	Range	Defaults	Type
15	Jog reference	0 to 400.0 Hz	1.5	RW

Defines the jog speed

No	Function	Range	Defaults	Type
16	Analog input 1 mode	0-20, 20-0, 4-20, 20-4, 4-.20, 20-.4, VoLt	4-.20	RW

Determines the input on terminal T2

0-20: Current input 0 to 20mA (20mA full scale)

20-0: Current input 20 to 0mA (0mA full scale)

4-20: Current input 4 to 20mA with current loop loss (cL1) trip (20mA full scale)

20-4: Current input 20 to 4mA with current loop loss (cL1) trip (4mA full scale)

4-.20: Current input 4 to 20mA with no current loop loss (cL1) trip (20mA full scale)

20-.4: Current input 20 to 4mA with no current loop loss (cL1) trip (4mA full scale)

VoLt: 0 to 10V input

NOTE

In the 4-20 or 20-4mA modes (with current loop loss) the drive will trip on cL1 if the input reference is below 3mA. Also, if the drive trips on cL1, the voltage analog input cannot be selected.

NOTE

If both analog inputs (A1 and A2) are to be set-up as voltage inputs, and if the potentiometers are supplied from the drive's +10V rail (terminal T3), they must have a resistance >4kΩ each.

No	Function	Range	Defaults	Type
17	Enable negative preset speeds	OFF or On	OFF	RW

OFF: Direction of rotation controlled by run forward and run reverse terminals

On: Direction of rotation controlled by preset speed values (use run forward terminal)

No	Function	Range	Defaults	Type
18	Preset speed 1	±1500 Hz (Limited by setting of Pr 02 <i>Maximum set speed</i>)	0.0	RW
19	Preset speed 2			
20	Preset speed 3			
21	Preset speed 4			

Defines preset speeds 1 to 4.

No	Function	Range	Defaults	Type
22	Load display units	Ld, A	Ld	RW

Ld: Active current as a % of motor rated active current

A: Drive output current per phase in A

No	Function	Range	Defaults	Type
23	Speed display units	Fr, SP, Cd	Fr	RW

Fr: Drive output frequency in Hz

SP: Motor speed in rpm

Cd: Machine speed in customer defined units (See Pr 24).

No	Function	Range	Defaults	Type
24	Customer defined scaling	0 to 9.999	1.000	RW

Multiplying factor on motor speed (rpm) to give customer defined units.

No	Function	Range	Defaults	Type
25	User security code	0 to 999	0	RW

Used to set-up a user security code. See section 5.6 *Security codes* on page 19.

No	Function	Range	Defaults	Type
26	Not used			

No	Function	Range	Defaults	Type
27	Power up keypad reference	0, LAsT, PrS1	0	RW

0: keypad reference is zero

LAsT: keypad reference is last value selected before the drive was powered down

PrS1: keypad reference is copied from preset speed 1

No	Function	Range	Defaults	Type
28	Parameter cloning	no, rEAd, Prog, boot	no	RW

no: no action

rEAd: program the drive with the contents of the SmartStick

Prog: program the SmartStick with the current drive settings

boot: SmartStick becomes read only. The contents of the SmartStick will be copied to the drive every time the drive is powered up.

NOTE Before setting boot mode, the current drive settings must be stored in the SmartStick by using Prog mode, otherwise the drive will trip on C.Acc at power-up.

Parameter cloning is initiated by pressing the  MODE key on exit from parameter edit mode after Pr **28** has been set to rEAd, Prog or boot.

NOTE If parameter cloning is enabled when no SmartStick is fitted to the drive, the drive will trip on C.Acc.

NOTE The SmartStick can be used to copy parameters between drives of different ratings. Certain drive dependant parameters will be stored on the SmartStick but will not be copied to the cloned drive.

The drive will trip on C.rtg when being written to by a cloned parameter set of a different drive rating.

The drive dependant parameters are: Pr **06** Motor rated current, Pr **08** Motor rated voltage, Pr **09** Motor power factor and Pr **37** Maximum switching frequency.

NOTE For best motor performance, an autotune should be carried out after parameter cloning has taken place.

No	Function	Range	Defaults	Type
29	Load defaults	no, Eur, USA	no	RW

no: defaults are not loaded

Eur: 50Hz default parameters are loaded

USA: 60Hz default parameters are loaded

Default parameters are set by pressing the  MODE key on exit from parameter edit

mode after Pr **29** has been set to Eur or USA.

When default parameters have been set, the display will return to Pr **01** and Pr **10** will be reset to L1.

NOTE The drive must be in a disabled, stopped or tripped condition to allow default parameters to be set. If default parameters are set while the drive is running, the display will flash FAIL once before changing back to no.

No	Function	Range	Defaults	Type
30	Ramp mode select	0 to 3	1	RW

- 0:** Fast ramp selected
- 1:** Standard ramp with normal motor voltage selected
- 2:** Standard ramp with high motor voltage selected
- 3:** Fast ramp with high motor voltage selected

Fast ramp is linear deceleration at programmed rate, normally used when a braking resistor is fitted.

Standard ramp is controlled deceleration to prevent DC bus over-voltage trips, normally used when there is no braking resistor fitted.

If a high motor voltage mode is selected, deceleration rates can be faster for a given inertia but motor temperatures will be higher.

No	Function	Range	Defaults	Type
31	Stop mode select	0 to 4	1	RW

- 0:** Coast to stop selected
- 1:** Ramp to stop selected
- 2:** Ramp to stop with 1 second DC injection braking
- 3:** DC injection braking with detection of zero speed
- 4:** Time DC injection braking

See the *VariFlex Advanced User Guide*.

No	Function	Range	Defaults	Type
32	Dynamic V to f select	OFF or On	OFF	RW

OFF: Fixed linear voltage to frequency ratio (constant torque - standard load)

On: Voltage to frequency ratio dependant on load current (dynamic/variable torque/ load). This gives a higher motor efficiency.

No	Function	Range	Defaults	Type
33	Catch a spinning motor select	0 to 3	0	RW

- 0:** Disabled
- 1:** Detect positive and negative frequencies
- 2:** Detect positive frequencies only
- 3:** Detect negative frequencies only

If the drive is to be configured in fixed boost mode (Pr **41** = Fd or SrE) with catch a spinning motor software enabled, an autotune (see Pr **38** on page 31) must be carried out to measure the motor's stator resistance beforehand. If a stator resistance is not measured, the drive may trip on OV and OI.AC while trying to catch a spinning motor.

No	Function	Range	Defaults	Type
34	Terminal B7 mode select	dig, th, Fr, Fr.hr	dig	RW

- dig:** Digital input
- th:** Motor thermistor input, connect as per diagram below

Safety Information
Rating Data
Mechanical Installation
Electrical Installation
Keypad and Display
Parameters
Quick Start Commissioning
Diagnostics
Options
Parameter List
UL Listing Information

Fr: Frequency input. See *VariFlex Advanced User Guide*.

Fr.hr: High resolution frequency input. See *VariFlex Advanced User Guide*.

Figure 6-11

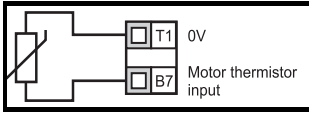

Trip resistance: 3kΩ

Reset resistance 1k8

NOTE

If Pr **34** is set to th so that terminal B7 is used as a motor thermistor, the functionality of terminal B7 as set-up with Pr **05**, drive configuration, will be disabled.

No	Function	Range	Defaults	Type
35	Digital output control (terminal B3)	n=0, At.SP, Lo.SP, hEAL, Act, ALAr, I.Lt, At.Ld, USEr	n=0	RW

n=0: At zero speed

At.SP: At speed

Lo.SP: At minimum speed

hEAL: Drive healthy

Act: Drive active

ALAr: General drive alarm

I.Lt: Current limit active

At.Ld: At 100% load

USEr: User programmable

NOTE

This parameter is automatically changed by the setting of Pr **12**. When Pr **12** automatically controls the setting of this parameter, this parameter cannot be changed.

NOTE

A change to this parameter is only implemented if the drive is disabled, stopped or tripped and the  STOP/RESET key is pressed for 1s.

See the *VariFlex Advanced User Guide*.

No	Function	Range	Defaults	Type
36	Analog output control (terminal B1)	Fr, Ld, A, Por, USEr	Fr	RW

Fr: Voltage proportional to motor speed

Ld: Voltage proportional to motor load

A: Voltage proportional to output current

Por: Voltage proportional to output power

USEr: User programmable

NOTE

A change to this parameter is only implemented if the drive is disabled, stopped or tripped and the  STOP/RESET key is pressed for 1s.

See the *VariFlex Advanced User Guide*.

No	Function	Range	Defaults	Type
37	Maximum switching frequency	3, 6, 12, 18 kHz	3	RW

3: 3kHz

6: 6kHz

12: 12kHz

18: 18kHz

See the *VariFlex Technical Data Guide* for drive derating data.

NOTE

18kHz is not available on VariFlex size C.

No	Function	Range	Defaults	Type
38	Autotune	0 to 2	0	RW

- 0: No autotune
- 1: Non-rotating static autotune
- 2: Rotating autotune



When a rotating autotune is selected, the drive will accelerate the motor up to $\frac{2}{3}$ maximum speed in Pr **02**.

WARNING

NOTE The motor must be at a standstill before a non-rotating autotune is initiated.

NOTE The motor must be at a standstill and unloaded before a rotating autotune is initiated.

No	Function	Range	Defaults	Type
39	Motor rated frequency	0.0 to 1500.0 Hz	EUR: 50.0, USA: 60.0	RW

Enter the motor rated frequency (taken from the motor name plate).
 Defines the voltage to frequency ratio applied to the motor.

No	Function	Range	Defaults	Type
40	Number of motor poles	Auto, 2P, 4P, 6P, 8P	Auto	RW

- Auto:** Automatically calculates the number of motor poles from the settings of Pr **07** and Pr **39**
- 2P:** Set for a 2 pole motor
 - 4P:** Set for a 4 pole motor
 - 6P:** Set for a 6 pole motor
 - 8P:** Set for an 8 pole motor

No	Function	Range	Defaults	Type
41	Voltage mode select	Ur S, Ur, Fd, Ur A, Ur I, SrE	Ur I	RW

- Ur S:** Stator resistance is measured each time the drive is enabled and run
- Ur:** No measurement is taken
- Fd:** Fixed boost
- Ur A:** Stator resistance is measured the first time the drive is enabled and run
- Ur I:** Stator resistance measured at each power-up when the drive is enabled and run
- SrE:** Square law characteristic

In all Ur modes, the drive operates in open loop vector mode.

NOTE The drive default setting is Ur I mode which means that the drive will carry out an autotune every time the drive is powered-up and enabled. If the load is not going to be stationary when the drive is powered-up and enabled, then one of the other modes should be selected. Not selecting another mode could result in poor motor performance or OI.AC, It.AC or OV trips.

No	Function	Range	Defaults	Type
42	Low frequency voltage boost	0.0 to 50.0 %	3.0	RW

Determines the boost level when Pr **41** is set to Fd or SrE.

No	Function	Range	Defaults	Type
43	Serial communications baud rate	2.4, 4.8, 9.6, 19.2, 38.4	19.2	RW

2.4: 2400 baud
4.8: 4800 baud
9.6: 9600 baud
19.2: 19200 baud
38.4: 38400 baud

No	Function	Range	Defaults	Type
44	Serial comms address	0 to 247	1	RW

Defines the unique address for the drive for the serial interface.

No	Function	Range	Defaults	Type
45	Software version	1.00 to 99.99		RO

Indicates the version of software fitted to the drive.

Pr 46 to Pr 51 appear when Pr 12 is set to control a motor brake.

No	Function	Range	Defaults	Type
46	Brake release current threshold	0 to 200 %	50	RW
47	Brake apply current threshold		10	

Defines the brake release and brake apply current thresholds as a % of motor current.
 If the frequency is >Pr 48 and the current is >Pr 46, the brake release sequence is started.
 If the current is <Pr 47, the brake is applied immediately.

No	Function	Range	Defaults	Type
48	Brake release frequency	0.0 to 20.0 Hz	1.0	RW
49	Brake apply frequency		2.0	

Defines the brake release and brake apply frequencies.
 If the current is >Pr 46 and the frequency is > Pr 48, the brake release sequence is started.
 If the frequency is <Pr 49 and the drive has been commanded to stop, the brake is applied immediately.

No	Function	Range	Defaults	Type
50	Pre-brake release delay	0.0 to 25.0 s	1.0	RW

Defines the time between the frequency and load condition being met and the break being released. The ramp is held during this time.

No	Function	Range	Defaults	Type
51	Post brake release delay	0.0 to 25.0 s	1.0	RW

Defines the time between the brake being released and the ramp hold being released.

Figure 6-12 Brake function diagram

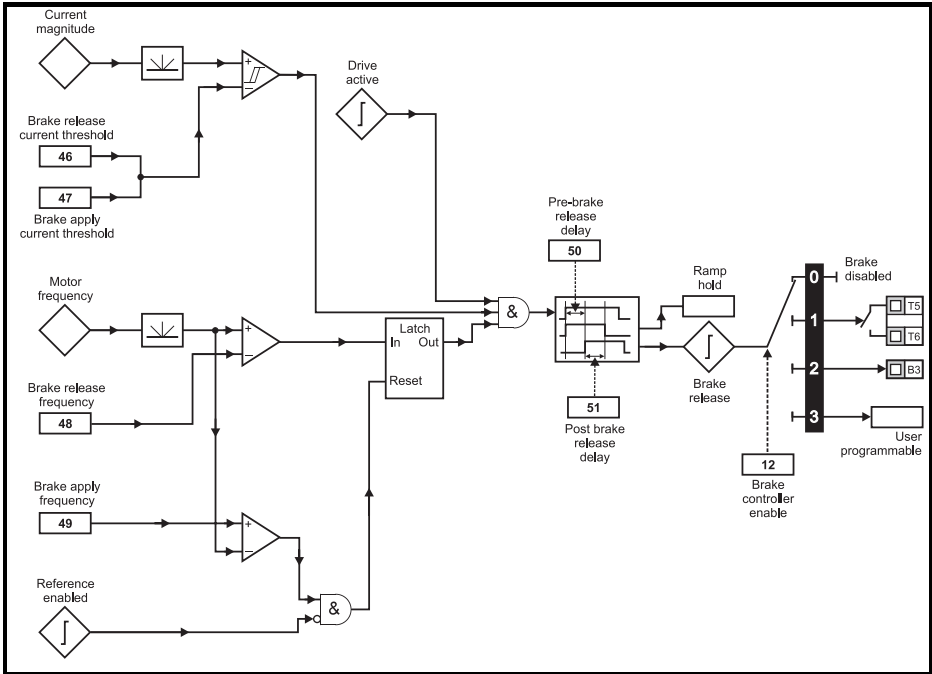
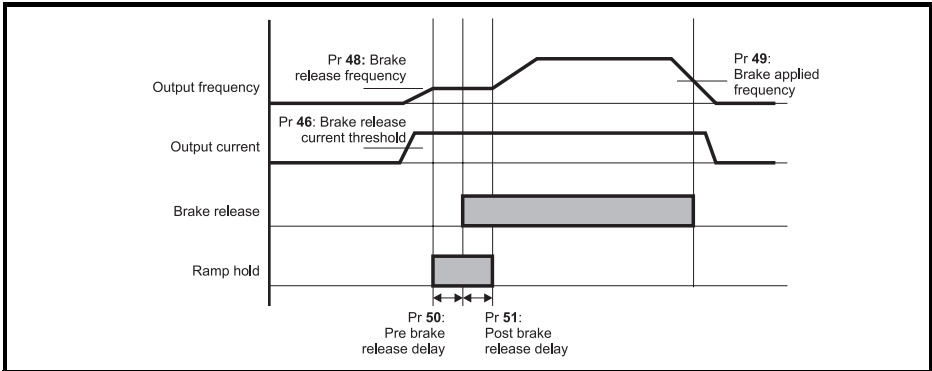

Figure 6-13 Brake sequence



Pr 52 to Pr 54 appear when a fieldbus Solutions Module is fitted to the drive.

No	Function	Range	Defaults	Type
52	Fieldbus node address	0 to 255	0	RW

No	Function	Range	Defaults	Type
53	Fieldbus baud rate	0 to 8	0	RW

No	Function	Range	Defaults	Type
54	Fieldbus diagnostics	-128 to +127	0	RW

See the appropriate fieldbus Solutions Module manual for further information.

No	Function	Range	Defaults	Type
55	Last trip		0	RO
56	Trip before Pr 55			
57	Trip before Pr 56			
58	Trip before Pr 57			

Indicates the last 4 trips of the drive.

No	Function	Range	Defaults	Type
59	PLC ladder program enable	0 to 2	0	RW

The PLC ladder program enable is used to start and stop the PLC ladder program.

0: Stop the PLC ladder program

1: Run the PLC ladder program (trip drive if LogicStick is not fitted). Any out-of-range parameter writes attempted will be limited to the maximum/minimum values valid for that parameter before being written to.

2: Run the PLC ladder program (trip drive if LogicStick is not fitted). Any out-of-range parameter writes attempted will cause the drive to trip.

See the *VariFlex Advanced User Guide* for details on PLC ladder programming.

No	Function	Range	Defaults	Type
60	PLC ladder program status	-128 to +127		RO

The PLC ladder program status parameter indicates the actual state of the PLC ladder program.

-n: PLC ladder program caused a drive trip due to an error condition while running rung n. Note that the rung number is shown on the display as a negative number.

0: LogicStick is fitted with no PLC ladder program

1: LogicStick is fitted, PLC ladder program is installed but stopped

2: LogicStick is fitted, PLC ladder program is installed and running

3: LogicStick is not fitted

No	Function	Range	Defaults	Type
61 to 70	Configurable parameter 1 to configurable parameter 10		As source	

Pr 61 to Pr 70 and Pr 71 to Pr 80 can be used to access and adjust advanced parameters.

Example: It is desired that Pr 1.29 (*Skip frequency 1*) is to be adjusted. Set one of the parameters Pr 71 to Pr 80 to 1.29, the value of Pr 1.29 will appear in the corresponding parameter from Pr 61 to Pr 70. I.e. if Pr 71 is set to 1.29, Pr 61 will contain the value of Pr 1.29 where it can be adjusted.

NOTE

Some parameters are only implemented if the drive is disabled, stopped or tripped and the  STOP/RESET key is pressed for 1s.

See *VariFlex Advanced User Guide* for advanced parameter details.

6.3 Parameter descriptions - Level 3

No	Function	Range	Defaults	Type
71 to 80	Pr 61 to Pr 70 set up	0 to Pr 21.51		RW

Set Pr **71** to Pr **80** to the required advanced parameter number to be accessed.

The value within these parameters will be displayed in Pr **61** to Pr **70**. Pr **61** to Pr **70** can then be adjusted to change the value within a parameter.

See *VariFlex Advanced User Guide* for further details.

6.4 Diagnostic parameters

The following read only (RO) parameters can be used as an aid to fault diagnosis on the drive. See Figure 8-1 *Diagnostics logic diagram* on page 41.

No	Function	Range	Type
81	Frequency reference selected	±Pr 02 Hz	RO
82	Pre-ramp reference	±Pr 02 Hz	RO
83	Post-ramp reference	±Pr 02 Hz	RO
84	DC bus voltage	0 to Drive maximum VDC	RO
85	Motor frequency	±Pr 02 Hz	RO
86	Motor voltage	0 to Drive rating V	RO
87	Motor speed	±9999 rpm	RO
88	Motor current	+Drive maximum A	RO
89	Motor active current	±Drive maximum A	RO
90	Digital I/O read word	0 to 95	RO
91	Reference enabled indicator	OFF (0) or On (1)	RO
92	Reverse selected indicator	OFF (0) or On (1)	RO
93	Jog selected indicator	OFF (0) or On (1)	RO
94	Analog input 1 level	0 to 100 %	RO
95	Analog input 2 level	0 to 100 %	RO

Safety Information
Rating Data
Mechanical Installation
Electrical Installation
Keypad and Display
Parameters
Quick Start Commissioning
Diagnostics
Options
Parameter List
UL Listing Information

7 Quick Start Commissioning

This procedure is written from default parameter settings as the drive would be delivered from the factory.

7.1 Terminal control

Figure 7-1 Minimum required control terminal connections

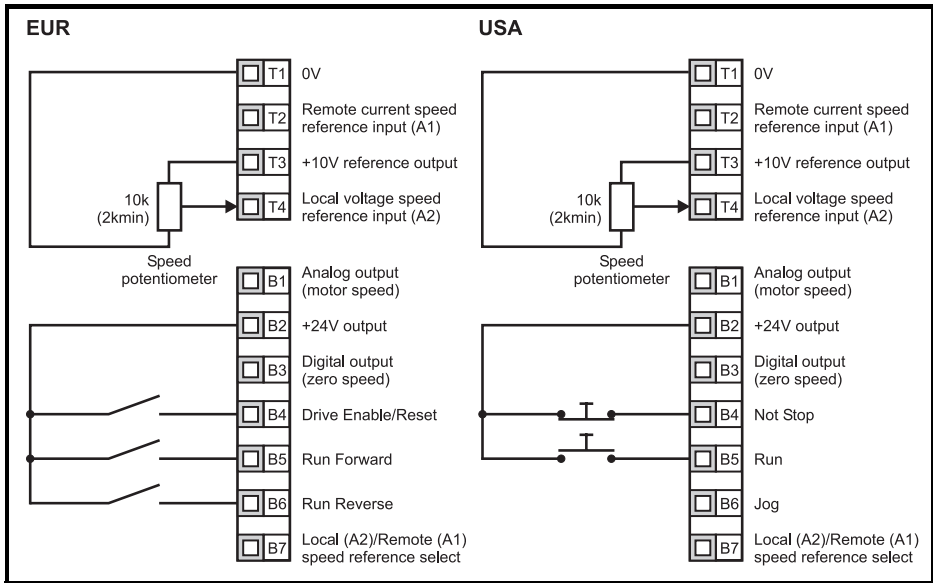

Terminal B7 open: Local voltage speed reference (A2) selected

Action	Detail	
Before power up	Ensure: <ul style="list-style-type: none"> The drive enable signal is not given, terminal B4 is open The run signal is not given, terminal B5/B6 is open The motor is connected to the drive The motor connection is correct for the drive Δ or Y The correct supply voltage is connected to the drive 	
Power up the drive	Ensure: <ul style="list-style-type: none"> The drive displays: Pr 00 	
Enter minimum and maximum speeds	Enter: <ul style="list-style-type: none"> Minimum speed Pr 01 (Hz) Maximum speed Pr 02 (Hz) 	
Enter acceleration and deceleration rates	Enter: <ul style="list-style-type: none"> Acceleration rate Pr 03 (s/100Hz) Deceleration rate Pr 04 (s/100Hz) 	
Enter motor nameplate details	Enter: <ul style="list-style-type: none"> Motor rated current in Pr 06 (A) Motor rated speed in Pr 07 (rpm) Motor rated voltage in Pr 08 (V) Motor rated power factor in Pr 09 If the motor is not a standard 50/60Hz motor, set Pr 39 accordingly 	
Ready to autotune		
Enable and run the drive	Close: <ul style="list-style-type: none"> The Enable and Run Forward or Run Reverse signals 	
Autotune	The VariFlex will carry out a non-rotating autotune on the motor. The motor must be stationary to carry out an autotune correctly. The drive will carry out a non-rotating autotune every time it is first started after each power-up. If this will cause a problem for the application, set Pr 41 to the required value.	
Autotune complete	When the autotune has been completed, the display will show: Pr 00	
Ready to run		
Run	The drive is now ready to run the motor.	
Increasing and decreasing speed	Turning the speed potentiometer will increase and decrease the speed of the motor.	
Stopping	To stop the motor under ramp control, open either the run forward or run reverse terminal. If the enable terminal is opened while the motor is running, the motor will coast to a stop.	

7.2

Keypad control

Figure 7-2 Minimum required control terminal connections

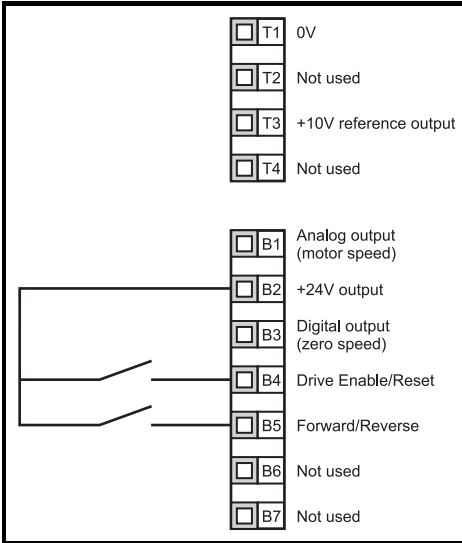

Action	Detail	
Before power up	Ensure: <ul style="list-style-type: none"> The drive enable signal is not given, terminal B4 is open The motor is connected to the drive The motor connection is correct for the drive Δ or Y The correct supply voltage is connected to the drive 	
Power up the drive	Ensure: <ul style="list-style-type: none"> The drive displays: Pr 00 	
Enter minimum and maximum speeds	Enter: <ul style="list-style-type: none"> Minimum speed Pr 01 (Hz) Maximum speed Pr 02 (Hz) 	
Enter acceleration and deceleration rates	Enter: <ul style="list-style-type: none"> Acceleration rate Pr 03 (s/100Hz) Deceleration rate Pr 04 (s/100Hz) 	
Set keypad control	Enter: <ul style="list-style-type: none"> PAd into Pr 05 	
Enter motor nameplate details	Enter: <ul style="list-style-type: none"> Motor rated current in Pr 06 (A) Motor rated speed in Pr 07 (rpm) Motor rated voltage in Pr 08 (V) Motor rated power factor in Pr 09 If the motor is not a standard 50/60Hz motor, set Pr 39 accordingly 	
Ready to autotune		
Enable and run the drive	Close: <ul style="list-style-type: none"> The enable signal Press the RUN key 	
Autotune	The VariFlex will carry out a non-rotating autotune on the motor. The motor must be stationary to carry out an autotune correctly. The drive will carry out a non-rotating autotune every time it is first started after each power-up. If this will cause a problem for the application, set Pr 41 to the required value.	
Autotune complete	When the autotune has been completed, the display will show: Fr 00	
Ready to run		
Run	The drive is now ready to run the motor.	
Increasing and decreasing speed	Press the UP key to increase the speed Press the DOWN key to decrease the speed	
Stopping	Press the STOP/RESET key to stop the motor	

NOTE To implement a Forward/Reverse switch, see the *VariFlex Advanced User Guide*.

Safety Information
Rating Data
Mechanical Installation
Electrical Installation
Keypad and Display
Parameters
Quick Start Commissioning
Diagnostics
Options
Parameter List
UL Listing Information

8 Diagnostics



Do not attempt to carry out internal repairs. Return a faulty drive to the supplier for repair.

WARNING

Trip code	Condition	Possible cause
UU	DC bus under voltage	Low AC supply voltage Low DC bus voltage when supplied by an external DC power supply
OV	DC bus over voltage	Deceleration rate set too fast for the inertia of the machine Mechanical load driving the motor
OI.AC**	Drive output instantaneous over current	Insufficient ramp times Phase to phase or phase to ground short circuit on the drives output Drive requires autotuning to the motor Motor or motor connections changed, re-autotune drive to motor
OI.br**	Braking resistor instantaneous over current	Excessive braking current in braking resistor Braking resistor value too small
O.SPd	Over speed	Excessive motor speed (typically caused by mechanical load driving the motor)
tunE	Auto tune stopped before completion	Run command removed before autotune complete
It.br	I^2t on braking resistor	Excessive braking resistor energy
It.AC	I^2t on drive output current	Excessive mechanical load High impedance phase to phase or phase to ground short circuit at drive output Drive requires re-autotuning to motor
O.ht1	IGBT over heat based on drives thermal model	Overheat software thermal model
O.ht2	Over heat based on drives heatsink	Heatsink temperature exceeds allowable maximum
th	Motor thermistor trip	Excessive motor temperature
O.Ld1*	User +24V or digital output overload	Excessive load or short circuit on +24V output
cL1	Analog input 1 current mode, current loss	Input current less than 3mA when 4-20 or 20-4mA modes selected
SCL	Serial communications loss time-out	Loss of communication when drive is under remote control
EEF	Internal drive EEPROM failure	Possible loss of parameter values (set default parameters (see Pr 29 on page 28))
PH	Input phase imbalance or input phase loss	One of the input phases has become disconnected from the drive (applies to 200/400V three phase drives only, not dual rated drives)
rS	Failure to measure motors stator resistance	Motor too small for drive Motor cable disconnected during measurement
C.Err	SmartStick data error	Bad connection or memory corrupt within SmartStick
C.dAt	SmartStick data does not exist	New/empty SmartStick being read
C.Acc	SmartStick read/write fail	Bad connection or faulty SmartStick
C.rtg	SmartStick/drive rating change	Already programmed SmartStick read by a drive of a different rating
O.cL	Overload on current loop input	Input current exceeds 25mA
HFxx trip	Hardware faults	Internal drive hardware fault (see <i>VariFlex Advanced User Guide</i>)

* The Enable/Reset terminal will not reset an O.Ld1 trip. Use the  Stop/Reset key.

** These trips cannot be reset for 10 seconds after they occur.

See the *VariFlex Advanced User Guide* for further information on possible causes of drive trips.

Table 8-1 DC bus voltages

Drive voltage rating	UV Trip	UV Reset	Braking level	OV trip
200V	175	215 *	390	415
400V	330	425 *	780	830

NOTE * These are the absolute minimum DC voltages the drives can be supplied by.

Table 8-2 Alarm warnings

Display	Condition	Solution
OUL.d	1 x t overload	Reduce motor current
hot	Heatsink/IGBT temperature high	Reduce ambient temperature or reduce motor current
br.rS	Braking resistor overload	See <i>VariFlex Advanced User Guide</i>

NOTE If no action is taken when an alarm warning appears, the drive will trip on the appropriate fault code.

Figure 8-1 Diagnostics logic diagram

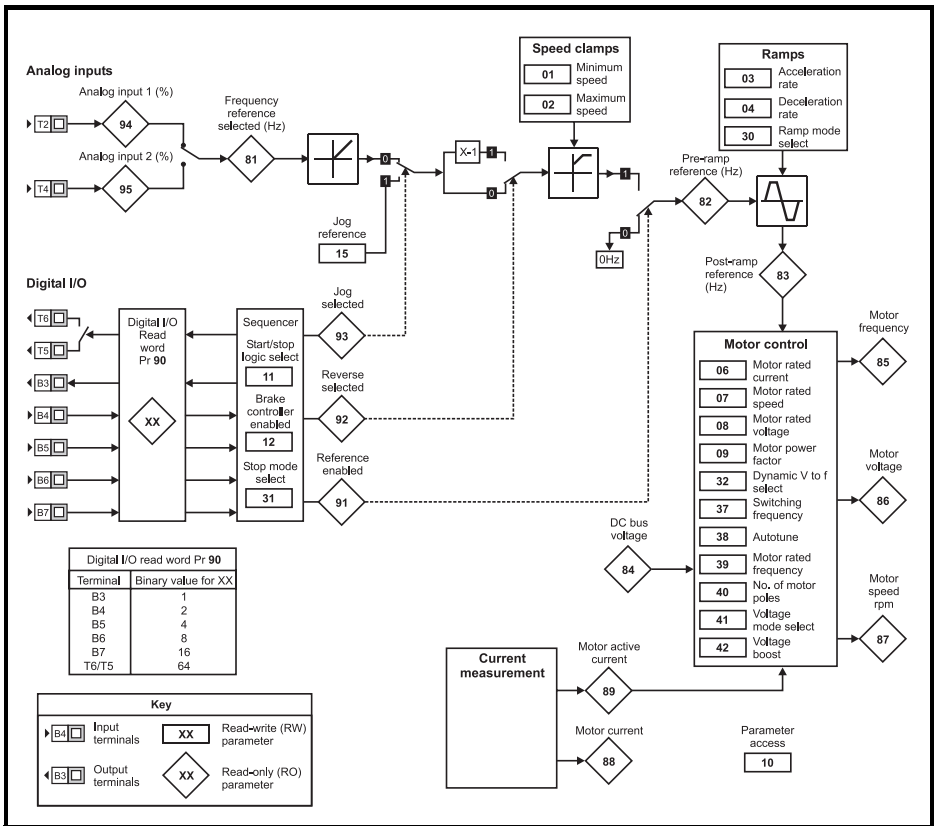









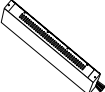

Cooling fan control (size B and C only)

As default, the drive's cooling fan is controlled by the drive. The fan will remain off until the heatsink temperature reaches 60°C or the output current rises above 75% of the drive rating. The fan will then switch on and run at full speed for a minimum of 10s.

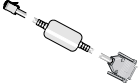
For further details, see the *VariFlex Advanced User Guide*.

9 Options

Option name	Function	Picture
SmartStick	Upload drive parameters to the SmartStick for storage or for easy set-up of identical drives or downloading to replacement drives	
LogicStick	The LogicStick plugs into the front of the drive and enables the user to program PLC functions within the drive The LogicStick can also be used as a SmartStick	
SM-I/O Lite*	Additional input/output module without real time clock	
SM-Timer I/O*	Additional input/output module with real time clock	
SM-PROFIBUS-DP*	Fieldbus communications modules	
SM-DeviceNet*		
SM-CANopen*		
SM-INTERBUS*		
SM-Ethernet*		
SM-Keypad Plus	Remote panel mounting LCD multilingual text keypad display to IP54 (NEMA 12) with additional help key	
CG-Keypad Remote	Remote panel mounting LED display to IP54 (NEMA 12) with additional function key	
EMC filters	These additional filters are designed to operate together with the drive's own integral EMC filter in areas of sensitive equipment	
SK-Bracket	Cable management bracket	
Top cover kit	The additional top cover kit will increase the environmental protection of the top face to IP4X in vertical direction.	
CT comms cable	Cable with isolation RS232 to RS485 converter. For connecting PC/ Laptop to the drive when using CTSOft or SyPTLite	
AC input line reactors	To reduce supply harmonics	
CGSOft	Software for PC or Laptop which allows the user to commission and store parameter settings	
SyPTLite	Software for PC or Laptop which allows the user to program PLC functions within the drive	
UL type 1 kit	Bottom metal gland plate, top cover and side covers to allow the drive to comply with the requirements of UL type 1	

* Only applicable to sizes B and C

Details of all the above options can be found at www.controltechniques.com.

9.1 Documentation

As well as the *VariFlex Getting Started Guide*, a number of other guides are available for VariFlex :

VariFlex Technical Data Guide

This gives all the technical data for the drive, such as:

- Fuse sizes
- Cable sizes
- Braking resistor information
- IP ratings
- Pollution degree
- Vibration specifications
- Humidity
- Altitude
- Weights
- Losses
- De-rating info
- EMC filter info

VariFlex Advanced User Guide

This gives detailed information on all of the drive's advanced parameters and also on the serial communications. Furthermore, it gives set-up examples for the drive.

VariFlex EMC Guide

This gives comprehensive EMC information on the drive.

Option Module User Guides / Installation Sheets

These guides provide detailed information and set-up instructions for the various options available for VariFlex .

All of these guides can be found on the CD supplied with the drive or downloaded from www.controltechniques.com.

Safety Information
Rating Data
Mechanical Installation
Electrical Installation
Keypad and Display
Parameters
Quick Start Commissioning
Diagnostics
Options
Parameter List
UL Listing Information

10 Parameter List



Par	Description	Default		Setting 1	Setting 2
		EUR	USA		
Level 1 parameters					
01	Minimum set speed (Hz)	0.0			
02	Maximum set speed (Hz)	50.0	60.0		
03	Acceleration rate (s/100Hz)	5.0			
04	Deceleration rate (s/100Hz)	10.0			
05	Drive configuration	AI.AV			
06	Motor rated current (A)	Drive rating			
07	Motor rated speed (rpm)	1500	1800		
08	Motor rated voltage (V)	230 / 400		230 / 460	
09	Motor power factor (cos φ)	0.85			
10	Parameter access	L1			
Level 2 parameters					
11	Start/Stop logic select	0	4		
12	Brake controller enable	diS			
13	Not used				
14					
15	Jog reference (Hz)	1.5			
16	Analog input 1 mode (mA)	4-.20			
17	Enable negative preset speeds	OFF			
18	Preset speed 1 (Hz)	0.0			
19	Preset speed 2 (Hz)	0.0			
20	Preset speed 3 (Hz)	0.0			
21	Preset speed 4 (Hz)	0.0			
22	Load display units	Ld			
23	Speed display units	Fr			
24	Customer defined scaling	1.000			
25	User security code	0			
26	Not used				
27	Power up keypad reference	0			
28	Parameter cloning	no			
29	Load defaults	no			
30	Ramp mode select	1			
31	Stop mode select	1			
32	Dynamic V to f select	OFF			
33	Catch a spinning motor select	0			
34	Terminal B7 mode select	dig			
35	Digital output control (terminal B3)	n=0			
36	Analog output control (terminal B1)	Fr			
37	Maximum switching frequency (kHz)	3			
38	Autotune	0			
39	Motor rated frequency (Hz)	50.0	60.0		
40	Number of motor poles	Auto			
41	Voltage mode select	Ur 1			
42	Low frequency voltage boost (%)	3.0			
43	Serial communications baud rate	19.2			
44	Serial comms address	1			
45	Software version				
46	Brake release current threshold (%)	50			
47	Brake apply current threshold (%)	10			

Par	Description	Default		Setting 1	Setting 2
		EUR	USA		
48	Brake release frequency (Hz)		1.0		
49	Brake apply frequency (Hz)		2.0		
50	Pre-brake release delay (s)		1.0		
51	Post brake release delay (s)		1.0		
52	Fieldbus node address		0		
53	Fieldbus baud rate		0		
54	Fieldbus diagnostics		0		
55	Last trip		0		
56	Trip before Pr 55		0		
57	Trip before Pr 56		0		
58	Trip before Pr 57		0		
59	PLC ladder program enable		0		
60	PLC ladder program status				
61	Configurable parameter 1				
62	Configurable parameter 2				
63	Configurable parameter 3				
64	Configurable parameter 4				
65	Configurable parameter 5				
66	Configurable parameter 6				
67	Configurable parameter 7				
68	Configurable parameter 8				
69	Configurable parameter 9				
70	Configurable parameter 10				
Level 3 parameters					
71	Pr 61 set-up parameter				
72	Pr 62 set-up parameter				
73	Pr 63 set-up parameter				
74	Pr 64 set-up parameter				
75	Pr 65 set-up parameter				
76	Pr 66 set-up parameter				
77	Pr 67 set-up parameter				
78	Pr 68 set-up parameter				
79	Pr 69 set-up parameter				
80	Pr 70 set-up parameter				
81	Frequency reference selected				
82	Pre-ramp reference				
83	Post-ramp reference				
84	DC bus voltage				
85	Motor frequency				
86	Motor voltage				
87	Motor speed				
88	Motor current				
89	Motor active current				
90	Digital I/O read word				
91	Reference enabled indicator				
92	Reverse selected indicator				
93	Jog selected indicator				
94	Analog input 1 level				
95	Analog input 2 level				

Safety Information
Rating Data
Mechanical Installation
Electrical Installation
Keypad and Display
Parameters
Quick Start Commissioning
Diagnostics
Options
Parameter List
UL Listing Information

11 UL Listing Information

Table 11-1 Approvals

	CE approval	Europe
	C Tick approval pending	Australia
	UL / cUL approval pending	USA & Canada

11.1 Common UL information (for VariFlex size A and B)

11.1.1 Conformity

The drive conforms to UL listing requirements only when the following are observed:

- Class 1 60/75°C (140/167°F) copper wire only is used in the installation
- The ambient temperature does not exceed 40°C (104°F) when the drive is operating
- The terminal tightening torques specified in section 4.1 *Power terminal connections* are used
- The drive is installed into a separate electrical enclosure. The drive has a UL 'Opentype' enclosure rating

11.1.2 AC supply specification

The drive is suitable for use in a circuit capable of delivering not more than 100,000 RMS symmetrical Amperes at 264Vac RMS maximum (200V drives) or 528Vac RMS maximum (400V drives).

11.1.3 Motor overload protection

The drive provides motor overload protection. The overload protection level is 150% of full-load current. It is necessary for the motor rated current to be entered into Pr **06** for the protection to operate correctly. The protection level may be adjusted below 150% if required. Refer to the *VariFlex Advanced User Guide* for further information.

11.1.4 Overspeed protection

The drive provides overspeed protection. However, it does not provide the level of protection afforded by an independent high integrity overspeed protection device.

11.2 Power dependant UL information

11.2.1 VariFlex size A and B

Conformity

The drive conforms to UL listing requirements only when the following is observed:

- UL listed class CC fast acting fuses e.g. Bussman Limitron KTK series, Gould Amp-Trap ATM series or equivalent are used in the AC supply.

