

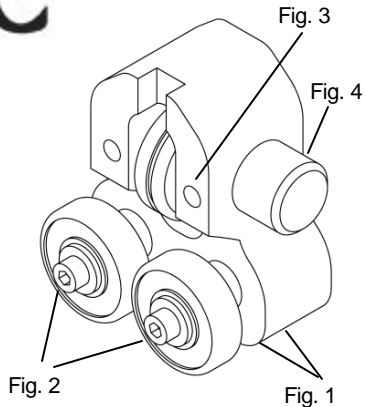

## GUIDALL 500/600 ADJUSTMENT INSTRUCTIONS



1. **CAUTION:** Be sure to disconnect the saw from the power supply before making any adjustments to the band saw guides.
2. Make sure blade tension is adjusted correctly and the blade is tracking properly before adjusting guides to the blade.
3. Adjust the side support assemblies by loosening the hex set screw on the bottom of the guide. (Fig. 1) Using another hex wrench, rotate the bearings (Fig. 2) to bring them in or out from the blade so that the bearings are a couple of thousandths of an inch (about the thickness of a piece of paper) away from the blade.
4. The rear thrust wheel should be adjusted by loosening the locking set screw (Fig. 3) and rotating the knurled knob (Fig. 4) to bring the thrust wheel forward or backward until the back of the blade is just a couple of thousandths ahead of the inner surface of the groove in the thrust wheel. Lock the thrust wheel in place by retightening its set screw.

CARTER PRODUCTS COMPANY

2871 Northridge Drive NW - Grand Rapids, MI 49544 - Toll Free: 888-622-7837 - FAX: 616-647-3387

Web: [www.carterproducts.com](http://www.carterproducts.com) - E-mail: [Info@carterproducts.com](mailto:Info@carterproducts.com)