

Carter

2000 SERIES ADJUSTMENT INSTRUCTIONS

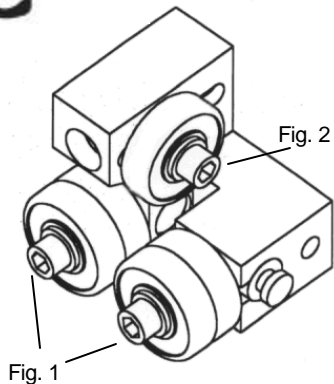

1. **CAUTION:** Be sure to disconnect the saw from the power supply before making any adjustments to the band saw guides.
2. Make sure blade tension is adjusted correctly and the blade is tracking properly before adjusting guides to the blade.
3. Each bearing assembly can be adjusted by loosening the socket head cap screw through the center of the bearing. (Fig. 1) Slide the side support bearing assemblies sideways so that the bearing is a couple of thousandths of an inch (about the thickness of a piece of paper) away from the blade. Then lock the bearing assemblies in place by retightening the socket cap screw securely.
4. Similarly, the lower thrust wheel should be adjusted by loosening the locking set screw (Fig. 2) and sliding the shaft forward or backward until the back of the blade is just a couple of thousandths ahead of the top surface of the thrust wheel. Lock the thrust wheel in place by retightening its set screw.
5. Both the upper and lower guide assemblies should be moved forward until the front edge of the side support bearings lie's just behind the gullet of the teeth of the blade.

CARTER PRODUCTS COMPANY

2871 Northridge Drive NW - Grand Rapids, MI 49544 - Toll Free: 888-622-7837 - FAX: 616-647-3387

Web: www.carterproducts.com - E-mail: Info@carterproducts.com