

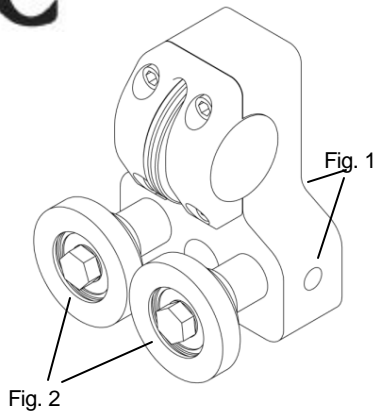

GUIDALL 400 ADJUSTMENT INSTRUCTIONS



1. **CAUTION:** Be sure to disconnect the saw from the power supply before making any adjustments to the band saw guides.
2. Make sure blade tension is adjusted correctly and the blade is tracking properly before adjusting the guides to blade.
3. Loosen the guide assembly and move the assembly forward or backward until the rear thrust bearing is a couple thousandths (about the thickness of a piece of paper) behind the back of the blade and aligned with the groove of the thrust bearing.
4. Adjust the side support bearing assemblies by loosening the hex set screw on the sides of the guide. (Fig.1) Using a 9/16" wrench, rotate the bearings (Fig. 2) to bring them in or out from the blade so that the bearings are a couple of thousandths of an inch away from the blade. At the same time, position the top surface of the bearing slightly behind the gullet of the blade. Lock the bearing assembly in place by retightening the side set screws securely.

CARTER PRODUCTS COMPANY

2871 Northridge Drive NW - Grand Rapids, MI 49544 - Toll Free: 888-622-7837 - FAX: 616-647-3387

Web: www.carterproducts.com - E-mail: Info@carterproducts.com