

Figure 1

## 1. General

- 1.1 This document describes the installation of the Workstation Multimedia Outlet (WMO) (Figure 1). The WMO is a compact telecommunications outlet designed to provide multiple connection points for both fiber optic and copper media.
- 1.2 This document is being reissued to include updated corporate information.

## 2. Carton Contents









- Base (1)
- Lid (1)
- #6-32 Mounting screws (4)
- #8-32 Mounting screws (4)
- Unit ID label (1)
- Clear label cover (1)
- Colored label cover (1)
- Blank panels (5)
- Cable ties (6)
- Blank icons (5)

## 3. Tools and Equipment

In addition to the tools and materials needed for sheath removal and connectorization, the following tools are needed to install a WMO:

- Phillips screw driver
- Utility knife

## 4. Precautions

	<b>WARNING: Never look directly into the end of a fiber that may be carrying laser light.</b> Laser light can be invisible and can damage your eyes. Viewing it directly does not cause pain. The iris of the eye will not close involuntarily as when viewing a bright light. Consequently, serious damage to the retina of the eye is possible. Should accidental eye exposure to laser light be suspected, arrange for an eye examination immediately.
	<b>WARNING: DO NOT</b> use magnifiers in the presence of laser radiation. Diffused laser light can cause eye damage if focused with optical instruments. Should accidental eye exposure to laser light be suspected, arrange for an eye examination immediately.
	<b>CAUTION:</b> Cleaved or broken glass fibers are very sharp and can pierce the skin easily. Do not let these pieces of fiber stick to your clothing or drop in the work area where they can cause injury later. Use tweezers to pick up cleaved or broken pieces of glass fibers and place them on a loop of tape kept for that purpose alone. <b>Good housekeeping is very important.</b>
	<b>CAUTION:</b> Recommend the use of safety glasses (spectacles) conforming to ANSI Z87, for eye protection from accidental injury when handling chemicals, cables or working with fiber. Pieces of glass fiber are very sharp and have the potential to damage the eye.
	<b>CAUTION:</b> Fiber optic cable is sensitive to excessive pulling, bending and crushing forces. Consult the cable specification sheet for the cable you are installing. Do not bend the cable more sharply than the minimum recommended bend radius. Do not apply more pulling force to the cable than specified. Do not crush the cable or allow it to kink. Doing so may cause damage that can alter the transmission characteristics of the cable; the cable may have to be replaced.
	<b>WARNING:</b> Do not install telecommunications equipment or work with telephone wiring during a lightning storm. Telephone lines can carry high voltages from lightning causing electrical shock resulting in severe injury or death.
	<b>CAUTION:</b> Avoid the possibility of electric shock from ring voltage when installing or modifying wiring by disconnecting the test jack. Never touch uninsulated wiring or terminals unless the test jack is unplugged.
	<b>CAUTION:</b> Do not install this unit in a wet location. Moisture will corrode terminals, degrading signal transmission.

**IMPORTANT:** Save all instructions and precautions received with this unit for future reference.

## 5. Connector Care and Cleaning



**WARNING:** Isopropyl alcohol is flammable with a flashpoint at 54°F. It can cause irritation to eyes on contact. In case of contact, flush eyes with water for at least 15 minutes. Inhalation of vapors irritates the respiratory tract. Exposure to high concentrations has a narcotic effect, producing symptoms of dizziness, drowsiness, headache, staggering, unconsciousness and possibly death.

- Always keep dust caps on connectors and adapters when not in use.
- Ensure dust caps are clean before reuse.
- Use optical cleaning materials as standardized by your company.
- Clean the connector before every mating, especially for test equipment patch cords (jumpers.)
- A minimum level of cleaning is listed below. Local procedures may require more rigorous cleaning methods.

**Step 1:** Remove plugs from the connector adapter.

**Step 2:** Wipe the connector ferrule twice with a lint-free wiping material moistened with isopropyl alcohol. Then wipe across the end of the ferrule.

**Step 3:** Repeat previous step with a dry wipe.

## 6. Removing the Lid

Remove the WMO lid by pulling straight up on the bottom side of the lid (Figure 2).

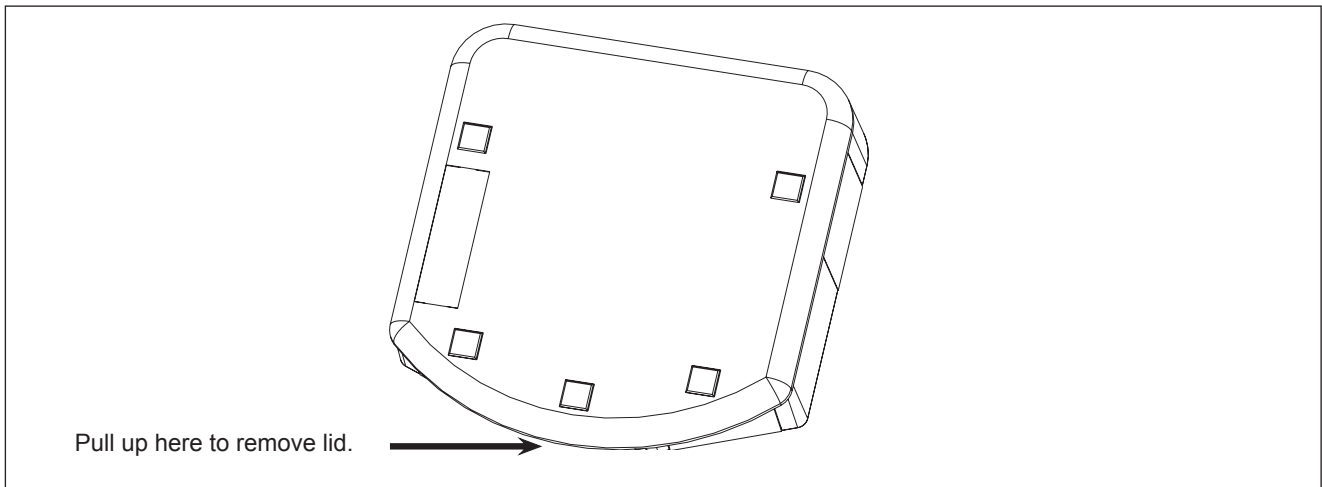

Figure 2

## 7. Preparing the WMO

**Remove breakouts for surface mount raceway.** The top end of the WMO has breakouts for standard  $\frac{3}{4}$ ", 1" or 1- $\frac{1}{2}$ " wide raceway. The WMO blank panels have similar breakouts for  $\frac{3}{4}$ " or 1" wide raceway, which allows any of the panel openings in the WMO to be used as a raceway entry point. Use a utility knife to remove the appropriate knockout. (Figure 3)

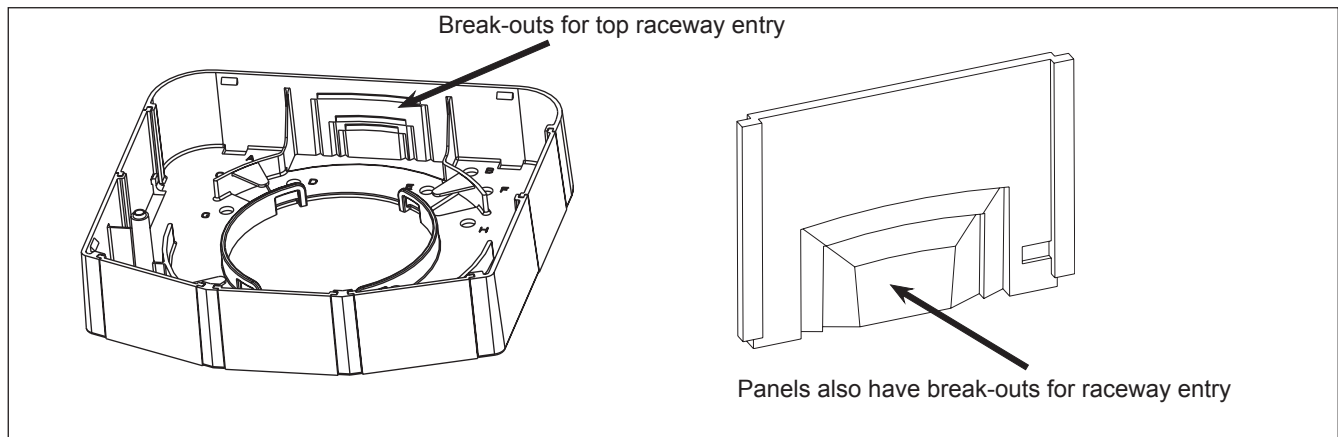

Figure 3

## 8. Outlet Mounting

**8.1** The mounting holes in the WMO base are labeled with letters to aid in identification of the proper holes to be used for each mounting application (Figure 4).

**8.2 Mounting to a standard electrical outlet box.** Use mounting holes D & K (or E & L) to mount the WMO to a single-gang electrical box. Use mounting holes C, F, J and M to mount the WMO to a double-gang electrical box. Some double-gang electrical boxes may require the use of holes A, B, N and O.

**8.3 Mounting directly to the wall.** Use the base to trace on the wall the screw locations for the mounting hole pattern of your choice. Also trace on the wall the large hole in the base. Cut out the hole in the wall and drill holes for the screws. Either install anchors in the screw holes or attach a back plate behind the sheet rock. Attach the WMO base to the anchors or back plate using the screws provided.

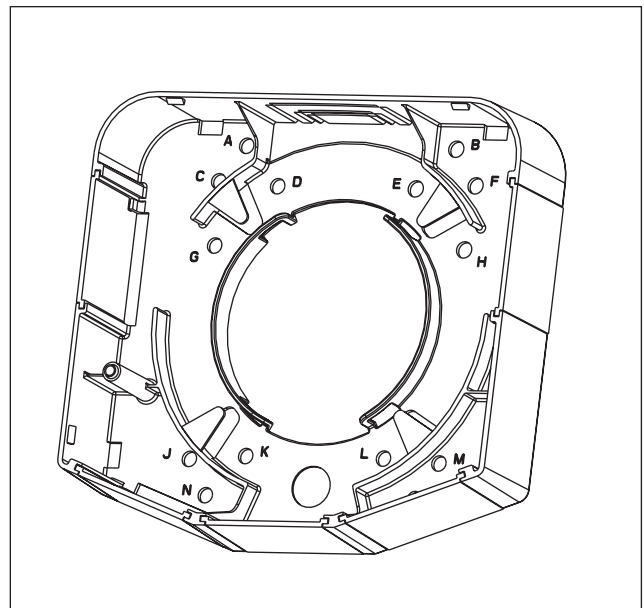

Figure 4

**8.4 Mounting to modular furniture.** There are several mounting brackets available for mounting to modular furniture. These brackets utilize hooks which slide into slots in the modular furniture walls, usually where two walls meet or at the end of a wall.

### 8.4.1 Steelcase®

- Order Corning Cable Systems P/N IO-MB-SC-L or IO-MB-SC-R when the WMO is being mounted where two in-line walls meet (– ◆ –).
- Using IO-MB-SC-L: Use mounting holes C and G in the WMO base to attach the bracket to the WMO such that the hooks in the bracket face downward. Then slide the hooks of the bracket into the slots in the furniture walls. The left end of the WMO will cover the slots in the wall and the rest will extend out to the right of the slots.
- Using IO-MB-SC-R: Use mounting holes F and H in the WMO base to attach the bracket to the WMO such that the hooks in the bracket face downward. Then slide the hooks of the bracket into the slots in the furniture walls. The right end of the WMO will cover the slots in the wall and the rest will extend out to the left of the slots.
- Order Corning Cable Systems P/N IO-MB-SC1-R when the WMO is being mounted at the right end of a wall (– ◆ –). Use mounting holes F and H in the WMO base to attach the bracket to the WMO such that the hooks in the bracket face downward. Then slide the hooks of the bracket into the slots in the furniture walls. The right end of the WMO will cover the slots and the rest will extend out to the left of the slots.
- Order Corning Cable Systems P/N IO-MB-SC1-L when the WMO is being mounted at the left end of a wall (– ◆ –). Use mounting holes F and H in the WMO base to attach the bracket to the WMO such that the hooks in the bracket face downward. Then slide the hooks of the bracket into the slots in the furniture walls. The left end of the WMO will cover the slots and the rest will extend out to the right of the slots.

### 8.4.2 Hayworth® - Order Corning Cable Systems P/N IO-MB-HAYWRTH-R or IO-MB-HAYWRTH-L.

- Use IO-MB-HAYWRTH-R when the WMO is being mounted at the left end of a wall or where two walls meet. Use mounting holes C, F, J and M in the WMO base to attach the bracket to the WMO such that the hooks in the bracket face downward. Then slide the hooks of the bracket into the slots in the furniture walls. The left end of the WMO will cover the slots in the wall and the rest will extend out to the right of the slots.
- Use IO-MB-HAYWRTH-L when the WMO is being mounted at the right end of a wall or where two walls meet. Use mounting holes C, F, J and M in the WMO base to attach the bracket to the WMO such that the hooks in the bracket face downward. Then slide the hooks of the bracket into the slots in the furniture walls. The right end of the WMO will cover the slots in the wall and the rest will extend out to the left of the slots.

### 8.4.3 Herman Miller

- Order Corning Cable Systems P/N IO-MB-HM2. Use mounting holes C and J (or F and M) to attach the bracket to the WMO. Then slide the hooks of the bracket into the slots in the furniture wall.

## 9. Installing Connector Panels

Install a connector panel in the desired location in the WMO base by sliding it into the grooves in the base and pushing down until the panel snaps into place. Remove a panel by pulling it straight out until the snaps release and the panel slides out of the grooves.

## 10. Fiber Installation

For MIC® cable, strip back 1 m (39 in) of jacket. Install connectors on the fibers per manufacturer's instructions. Tie wrap the cable jacket at one of the four tie wrap locations in the WMO. The cable sheath should lie on the outside portion of the spool in order to leave plenty of room for slack storage inside the spool (Figure 5). Route the fibers in the spool and insert the connectors into the appropriate adapters.

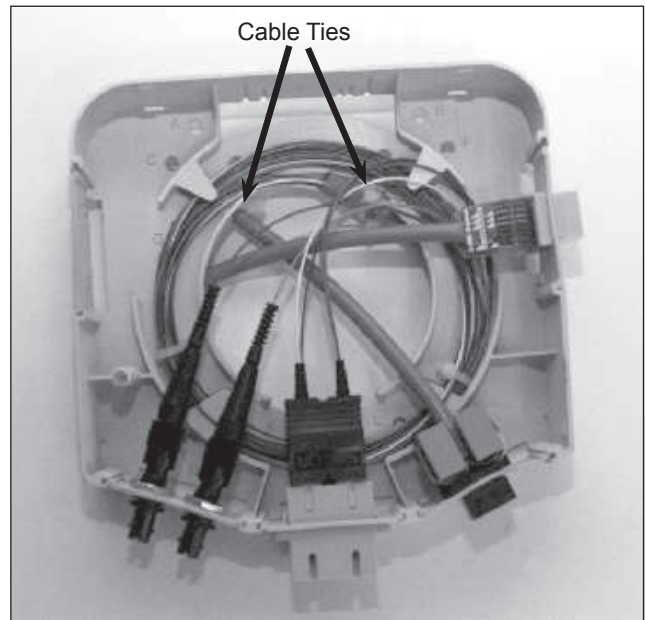

Figure 5

## 11. Copper Installation

Terminate the cable in the jack per manufacturer's instructions. Snap the jack into the WMO panel and slide the panel into place. Tie wrap the cable jacket at one of the four tie wrap locations in the WMO.

## 12. Faceplate Installation (optional).

**12.1** The WMO allows a single gang face plate (purchased separately from any faceplate manufacturer) to be placed on top of the WMO lid for additional capacity. Faceplate designs vary widely, so it is recommended that before beginning an on-site installation you perform a trial installation to ensure that the faceplate you have purchased will work with the WMO.

**12.2** Remove the large rectangular breakout from the WMO lid by cutting the scored areas with a utility knife and breaking out the rectangular center piece left (Figure 6). Also pierce the lid where the faceplate mounting screws will pass through. The small holes left in the lid are sized such that #6-32 machine screws may be threaded directly into the holes without a nut on the inside.

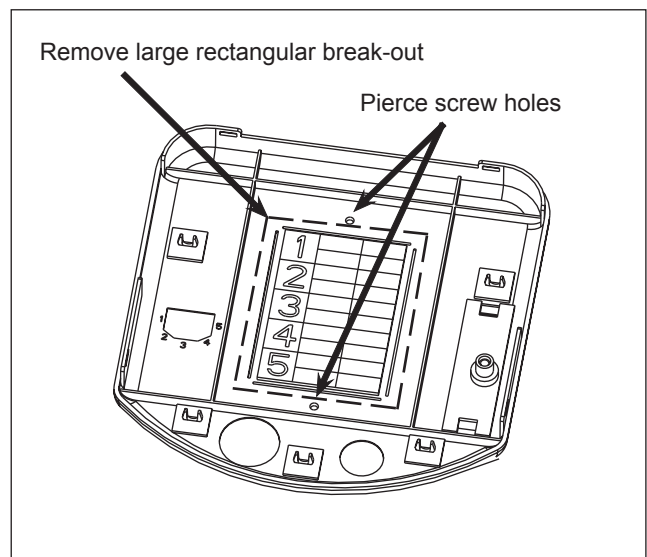

Figure 6

**12.3** Complete faceplate manufacturer's instructions for installing the faceplate. Be sure to pass the cable through the rectangular opening in the WMO lid before terminating cable on the faceplate.



### 13. Security Screw (optional)

The WMO allows a hidden security screw to be used (Figure 7).

### 14. Labeling

**14.1 Station ID.** Label the station ID using either of the following methods:

- Place an adhesive label from a hand-held label machine over the color matched flat strip on the WMO lid (Figure 8).
- Remove the color matched flat strip on the WMO lid. Instead, use the Station ID card and clear flat strip from the hardware kit. Either place an adhesive label on the Station ID card or simply write on the card.

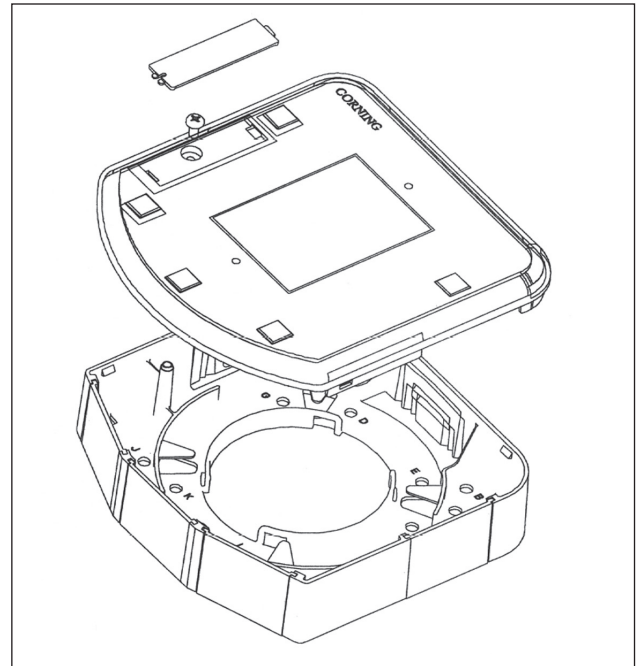

Figure 7

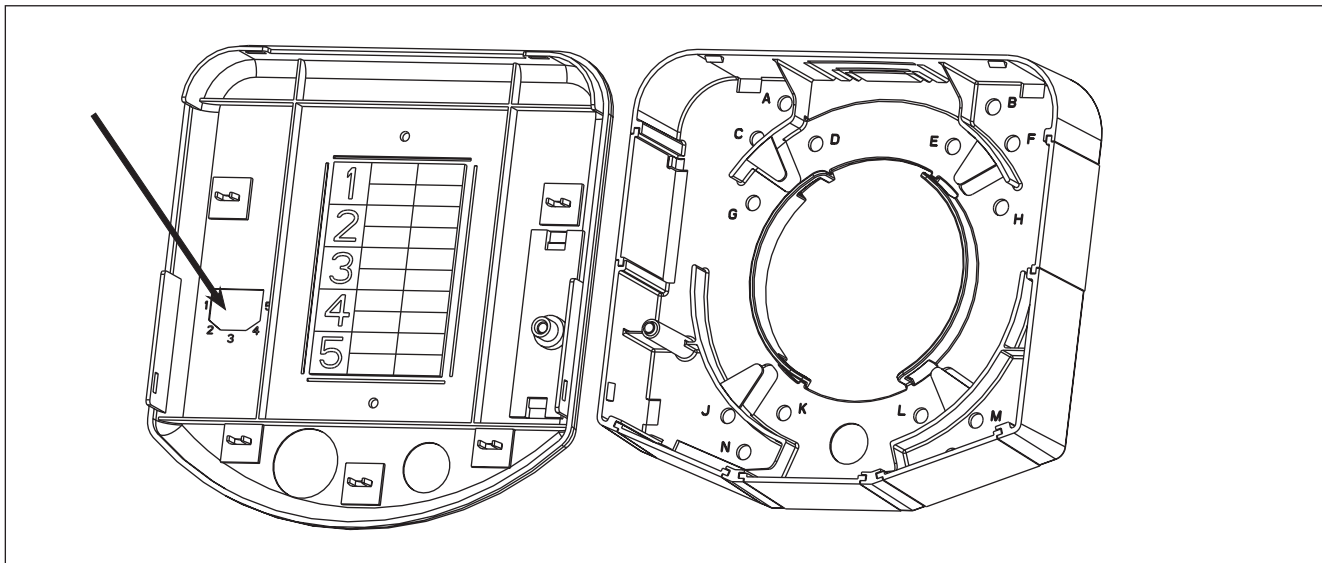

Figure 8

**14.2 Port ID.** Label the port ID using the label on the rear side of the WMO lid. Note that the port identification scheme on the rear side of the lid refers to the ports as viewed from the front with the lid removed.

**NOTE:** Using a faceplate on the WMO lid requires the removal of the port ID label. An alternate method of labeling port ID should be used (suggestion: place labels from a hand-held label machine over each port on the lid.)

Corning Optical Communications LLC • PO Box 489 • Hickory, NC 28603-0489 USA  
800-743-2675 • FAX 828-325-5060 • International +1-828-901-5000 • [www.corning.com/opcomm](http://www.corning.com/opcomm)

Corning Optical Communications reserves the right to improve, enhance, and modify the features and specifications of Corning Optical Communications products without prior notification. A complete listing of the trademarks of Corning Optical Communications is available at [www.corning.com/opcomm/trademarks](http://www.corning.com/opcomm/trademarks). All other trademarks are the properties of their respective owners. Corning Optical Communications is ISO 9001 certified. © 1998, 2001, 2014 Corning Optical Communications. All rights reserved. Published in Mexico.