

- Refer to Installation Guide 006-160 for complete instructions including jacketed cable applications.
- Visit [www.corning.com/opcomm/safety](http://www.corning.com/opcomm/safety) for full safety precautions
- Visit [www.corning.com/opcomm/videos](http://www.corning.com/opcomm/videos) for a video showing this procedure

### Tool Kit Contents

- Scissors
- Tweezers
- Dual-Hole Miller Tool
- Jacket Stripper
- Ruby Fiber Scribe
- Syringe, 3 cc
- Syringe Tip
- Anaerobic Adhesive
- Anaerobic Primer
- Fiber Optic Cleaning Wipes
- Fiber Optic Cleaning Fluid
- Permanent Marker
- Strip Length Card, LC
- Strip Length Card, SC/FC/ST® Compatible
- 1.25 mm Universal Polishing Puck
- 2.5 mm Universal Polishing Puck
- Yellow Polishing Film
- Gray Polishing Film
- White Polishing Film
- Clear Polishing Film
- 200x Microscope
- Crimp Tool, LC (orange)
- Crimp Tool, SC/FC/ST® Compatible (blue)

### Tool Kit Setup

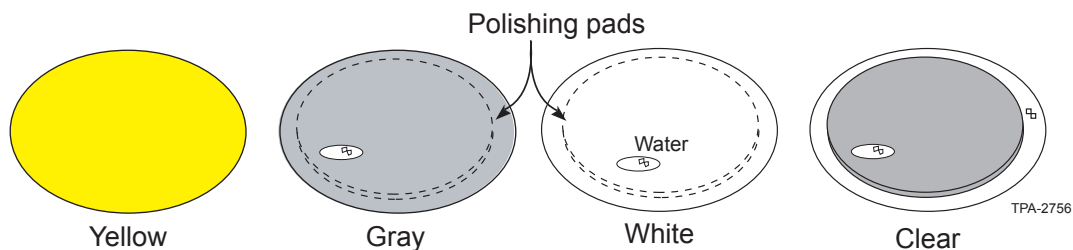

Figure 1 — Polishing film preparation: pads under Gray, White and Clear.

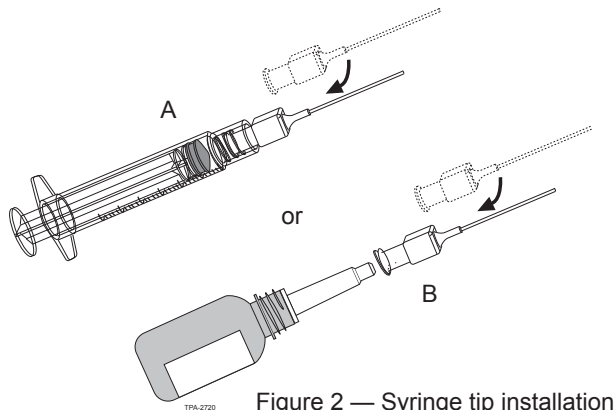

Figure 2 — Syringe tip installation

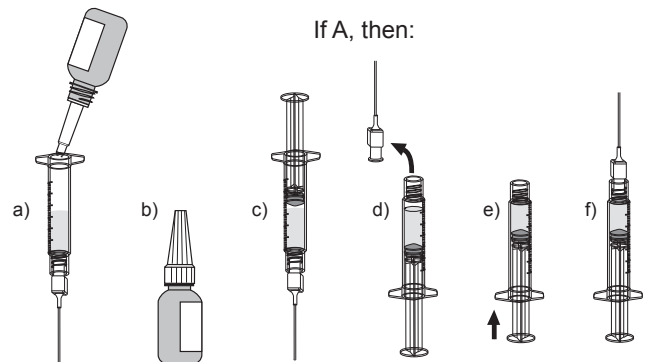
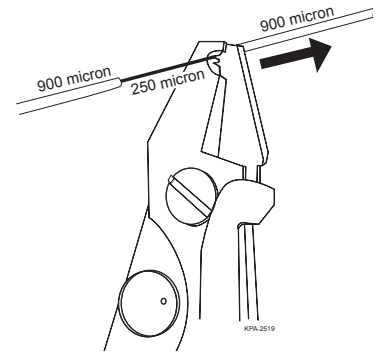
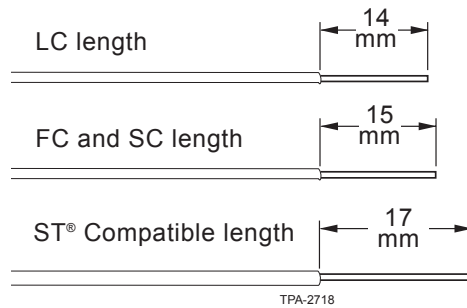
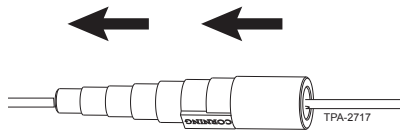

Figure 3 — Syringe preparation

## Fiber Preparation



- 1 Slide boot onto fiber first.
- 2 Measure to lengths shown and then strip with Dual-Hole Miller Tool.
- 3 Strip fiber and then clean.

## Connector Preparation and Termination

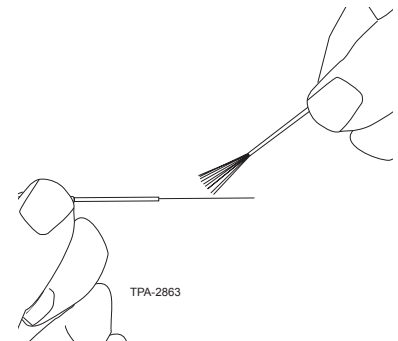
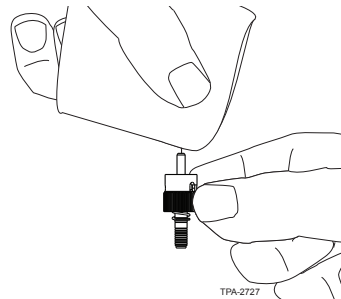
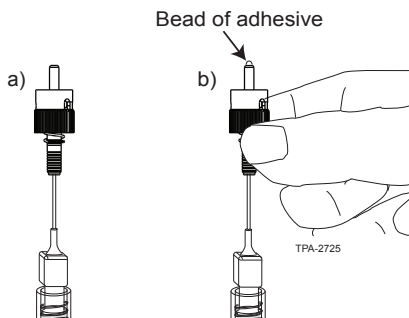

- 4 Inject adhesive until adhesive is barely visible; remove syringe tip.
- 5 Remove excess adhesive with lint-free wipe.
- 6 Apply primer to bare fiber.

Try to avoid getting primer on any of the fiber/cable other than the bare fiber.

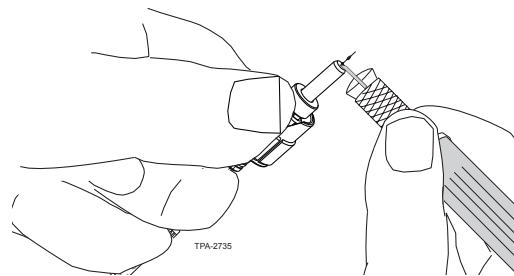
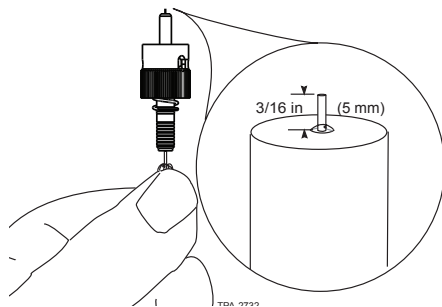

- 7 Insert fiber into connector until it bottoms out. 3/16 inch should be visible above the end face.
- 8 Gently slide the ruby scribe across edge of fiber and remove fiber fragment with tweezers.

## Connector Assembly

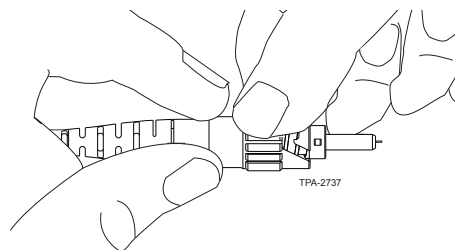

- 9 Slide boot up onto back of connector.

# Polishing

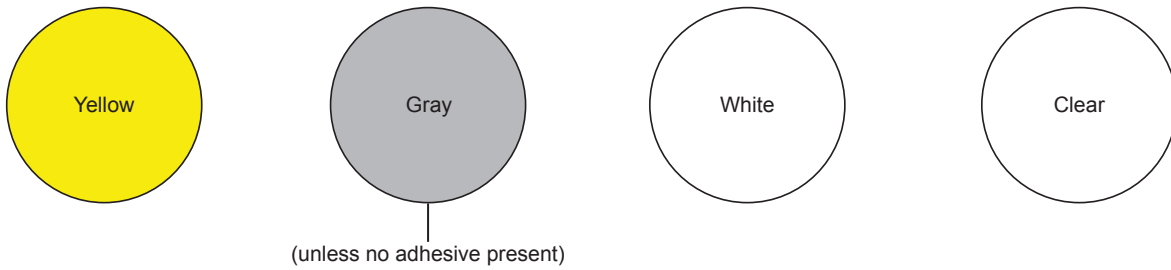

Figure 4 — Polishing film order

TPA-2757      TPA-2740      TPA-2746

**10** Remove fiber nub with 1-inch circles on the yellow film. Stop when the nub doesn't scratch the film anymore.

**11** Insert connector in polishing puck.

**12** Check for a small amount of adhesive.

Skip Gray polishing if no adhesive is present after Step 12.

TPA-2745      TPA-2745      TPA-2749      TPA-2750

**13** Complete one or two initial passes with very light pressure to ensure fiber nub is flush with adhesive bead.

**14** Make one figure-8 pattern at a time; check size of adhesive bead every time. Stop when bead is NEARLY gone.

**15** Clean bottom of puck with alcohol and wipes and the connector with a dry wipe.

**16** Make about 10 figure-8 patterns on WHITE polishing film with very light pressure then check end face for adhesive.

17 Repeat step 15 here.

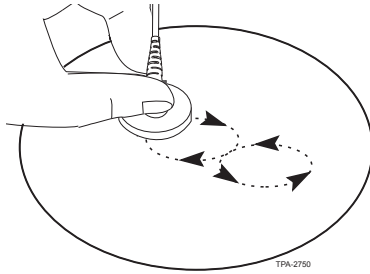

18 Make between 10 and 15 figure-8 patterns on CLEAR polishing film. Try to use NO pressure here.

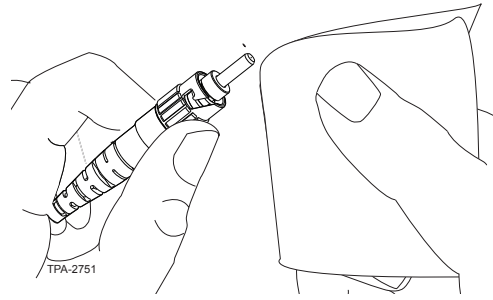

19 Clean connector with alcohol and wipes. Finish cleaning with a dry wipe.

## Testing

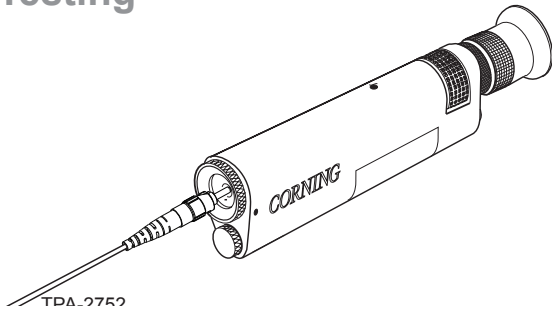

20 Insert connector into 200x microscope or probe. (See Figure 5 for acceptable results.)

21 Test with OTDR for Connector loss and reflectance.  
Test with power source and meter for end-to-end attenuation.

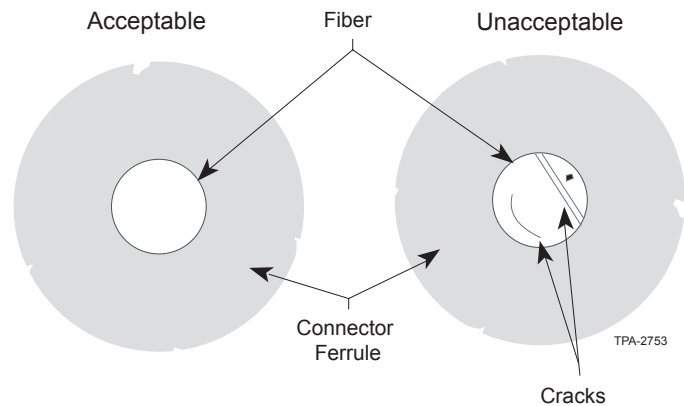

Figure 5 — Acceptable End Face. End face should look like left image. If you see right image, consult Troubleshooting section.

## Troubleshooting

Fiber insertion issues can be caused by:

- Fiber stripped too long; use lengths in step 2.
- Too much adhesive used; stop when adhesive is barely visible on end face.
- Adhesive curing too quickly could be caused by several possibilities:
  - Check expiration dates on both adhesive and primer.
  - If working in extreme high-heat / high-humidity conditions consider not applying the primer.

Pits may occur from:

- Excessive polishing on gray polishing film.

Shattered fibers can occur from:

- Improper excess fiber removal techniques.
- Inadvertent fiber breakage before or after scribing. Take care to protect the fiber.
- Excessive pressure on yellow polishing film.
- Excessive pressure on gray polishing film.

Cracks are caused by the same forces described above as well as:

- Small crescent-shaped cracks will occur when the gray polishing film is worn. Replace film and start over.

Corning Optical Communications LLC • PO Box 489 • Hickory, NC 28603-0489 USA  
800-743-2675 • FAX: 828-325-5060 • International: +1-828-901-5000 • [www.corning.com/opcomm](http://www.corning.com/opcomm)

Corning Optical Communications reserves the right to improve, enhance, and modify the features and specifications of Corning Optical Communications products without prior notification. A complete listing of the trademarks of Corning Optical Communications is available at [www.corning.com/opcomm/trademarks](http://www.corning.com/opcomm/trademarks). All other trademarks are the properties of their respective owners. Corning Optical Communications is ISO 9001 certified. © 2010, 2016 Corning Optical Communications. All rights reserved.