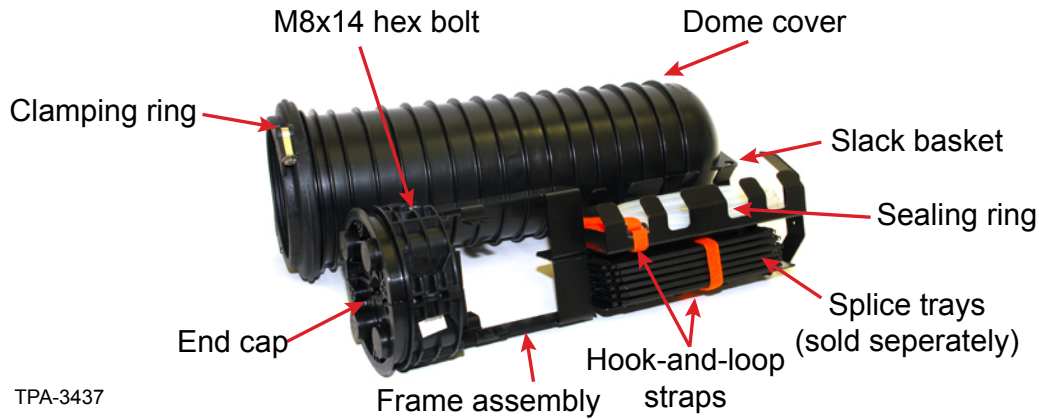

Table of Contents

1.	Carton Contents	2
2.	Tools and Materials Required	3
3.	Installing the Closure	3
3.1	Prepare the Express Cable	4
3.2	Install Grounding Hardware (Armored Cable Only)	4
3.3	Install Express Strain-relief Hardware	5
3.3.1	Strain-relieve Non-metallic Strength Members	5
3.3.2	Strain-relieve Metallic Strength Members	6
3.3.3	Strain-relieve Large Strength Members	7
3.4	Install Cable into the End Cap Express Ports	7
3.4.1	Prepare the End Cap	7
3.4.2	Apply Sealing Tape to the Cable	8
3.4.3	Install Cable	9
3.4.4	Use a Dummy Plug	9
3.4.5	Close End Cap Halves	9
3.4.6	Install Vented Grounding Screw	10
3.5	Ground Cable (Armored Cable Only)	10
3.6	Prepare Drop Cable Port(s)	10
3.7	Install Drop Port Cable into End Cap	11
3.8	Strain-relieve Drop Port Cables	12
3.9	Complete Frame Assembly	13
3.10	Attach Strain-relief Bracket	13
3.11	Tighten End Cap Compression Screw	13
3.12	Splice	13
3.12.1	Prepare Fiber for Splicing	13
3.12.2	Store Cable Slack	14
3.12.3	Secure Spliced Trays	14
3.13	Seal the Canister Closure	15
3.13.1	Install Seal	15
3.13.2	Install the Canister Cover	15
3.14	Install a Flash Test Air Valve	16
3.14.1	Install Valve Stem	16
3.14.2	Perform Flash Test	16
3.15	Ground the Closure	17
3.16	Reenter the Canister Closure	17
3.17	Reopen the End Cap	17



TPA-3437

1. Carton Contents

- (1) Dome cover
- (1) End cap
- (2) M8x14 hex bolts
- (1) Clamping ring
- (1) Sealing ring
- (1) Frame assembly
- (1) Slack basket (none in -02 and U-bar configurations)
- (1) Tray stacker (Two in -02 and U-bar configurations)
- (1) Accessory kit
- (1) Express port strain-relief kit
- (1) Drop port strain-relief kit
- (2) 18-in hook-and-loop straps (U-bar configuration has (1) 24-in strap only)
- (1) Tray retaining kit (U-bar only)

- A — Wrench for closing screw
- B — Wrench for grounding screw
- C — Maximum diameter for tape-wrapped cable in express ports
- D — Maximum cable diameter for medium (14 mm) rubber sealing grommet
- E — Maximum cable diameter for small (10 mm) rubber sealing grommet
- F — Maximum cable diameter for large (25 mm) rubber sealing grommet
- G — Wrench for compression screw
- H — End cap closing gauge
- K — Minimum cable diameter for smallest (5 mm) rubber sealing grommet

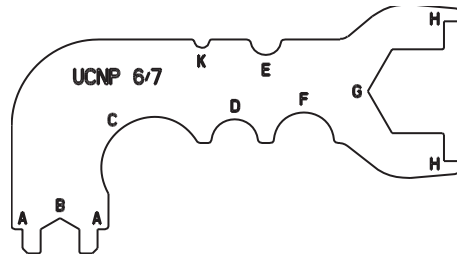

- A — Wrench for closing screw
- B — Wrench for grounding screw
- C — Maximum diameter for tape-wrapped cable in express ports
- D — Maximum cable diameter for medium (21 mm) rubber sealing grommet
- E — Maximum cable diameter for small (16.5 mm) rubber sealing grommet
- F — Maximum cable diameter for large (25 mm) rubber sealing grommet
- G — Wrench for compression screw
- H — End cap closing gauge
- K — Minimum cable diameter for small (12 mm) rubber sealing grommet
- L — Minimum cable diameter for smallest (8-11 mm) rubber sealing grommet

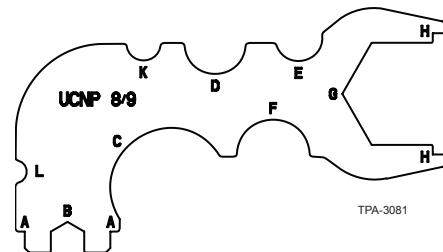

TPA-3081

Accessory kit (p/n SCF-6C/ 8C28-ACCY) contains:

- (1) Vented grounding screw
- (1) Solid grounding screw
- (1) Combination Wrench Tool
- (1) Alcohol cleaning tissue
- (1) Sealing paste - labeled "dichtpaste"
- (1) Sealing tape
- (5) Small cable ties
- (1) Brush
- (1) UCN lubricant
- (2) 8-in grounding wires
- (2) Grounding clamps
- (4) Flat washers
- (2) M6x40 Hex screws
- (2) M6x90 Hex screws

Express port cable strain-relief kit (SCF-KT-EXP-SM/8) contains:

- (2) Express brackets
- (2) 3/4 x 1 1/2-in hose clamps
- (2) 7/16 x 1-in hose clamps
- Large central member strain-relief kit (SCF-8 only) containing:
 - (2) 10-32 screws
- (2) Central member restraint caps
- (4) #8 washers
- (4) Nylon lock nuts
- (2) Barrels

Drop port cable strain-relief kit (p/n SCF-KT-6/8CBL) contains:

- (2) Drop brackets
- (2) 7/16 x 1-in hose clamps
- (2) Central member restraint caps
- (6) #8 washers
- (4) 8-32 lock nuts
- (2) #10-32 Philips screws
- (2) Toothed washers
- (2) Inside plastic grommets (lock nuts)
- (2) 17-21 mm sealing grommets
- (2) 12-16 mm sealing grommets
- (2) 8-11 mm sealing grommets
- (2) Outside plastic grommets (compression screw)
- (2) 21-25 mm sealing grommets (SCF-8 only)

2. Tools and Materials Required

The following tools and materials are required to complete this installation:

- Tape measure
- Scissors
- Side cutters
- Cable knife
- 11/32-in nut driver
- 3/8-in nut driver
- 5/16-in nut driver
- 7/16-in nut driver
- 1/2-in deep socket
- 10 mm socket
- Adjustable wrench
- Ratchet
- Heat-shrink Fusion Splice Protectors (p/n 2806032-01, package of 50, 40 mm long)
- Optical Fiber Access Tool (p/n OFT-000) in mid-span or cold weather applications
- Ideal® Coaxial cable stripper (p/n 100107-01)
- Slotted screwdriver
- Phillips screwdriver
- Permanent marker
- Paint marker
- Vinyl tape
- Hand pump
- Air pressure gauge
- Torque wrench
- Soapy water (to verify leaks)
- Isopropyl alcohol
- Hacksaw

3. Installing the Closure



WARNING: Do not install telecommunications equipment or work with telephone wiring during a lightning storm. Telephone lines can carry high voltages from lightning causing electrical shock resulting in severe injury or death.



CAUTION: The wearing of cut-resistant safety gloves to protect your hands from accidental injury when using sharp-bladed tools and armored cable is strongly recommended. Use extreme care when working with severed armor. There will be a sharp edge where armor is cut. To minimize the chance of injury from the cut armor, cover the exposed edge with a wrap of electrical tape. To minimize the chance of injury from sharp-bladed tools, always cut away from yourself and others. Dispose of used blades and armor scrap properly.



CAUTION: Recommend the use of safety glasses (spectacles) conforming to ANSI Z87 for eye protection from accidental injury when handling chemicals, cables, or working with fiber. Pieces of glass fiber are very sharp and have the potential to damage the eye.



CAUTION: Fiber optic cable is sensitive to excessive pulling, bending, and crushing forces. Consult the cable specification sheet for the cable you are installing. Do not bend the cable more sharply than the minimum recommended bend radius. Do not apply more pulling force to the cable than specified. Do not crush the cable or allow it to kink. Doing so may cause damage that can alter the transmission characteristics of the cable; the cable may have to be replaced.

3.1 Prepare the Express Cable

IMPORTANT: Typical lengths are illustrated. Since the actual application may vary, it is recommended to route the buffer tubes as they will lie in the closure to determine actual strip lengths before cutting fibers. Refer to routing illustration, if necessary.

Step 1: Remove indicated length of cable sheath and armor (where applicable) according to manufacture's directions.

NOTE: Do not expose the fibers until after the cables have been placed in the closure end cap.

End-span or drop cable

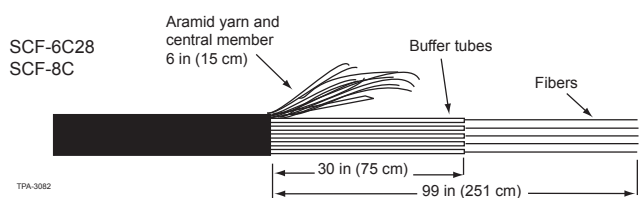
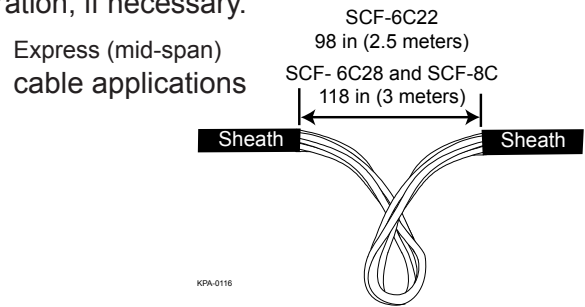
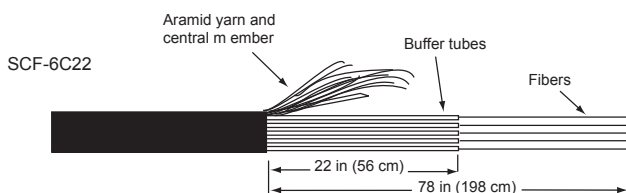

Step 2: Cut the central member of each cable to 6 in (approximately 15 cm) from the sheath using side cutters.

Step 3: If aramid yarn is present, leave 6 in (approximately 15 cm) of yarn for additional strain-relieving.

3.2 Install Grounding Hardware (Armored Cable Only)

If installing armored distribution or drop cable, it should be grounded to a primary ground. Ground armored cables using the hardware in the accessory kit as shown. Additional grounding hardware (p/n SCF-KT-6GND includes two #6 AWG ground leads and two ground clamp assemblies), if needed, may be purchased by contacting your customer service.

IMPORTANT: Do not install express cables until Section 3.4 or drop cables until Section 3.6.

Step 1: Cut a slit into opposite sides of the outer sheath and armor about 1 in (2.5 cm). To do this, score the armor with a cable knife (being careful not to damage the inner sheath, if present) and split the sheath by flexing it or use the ripcords to do the same thing when accessing the cable.

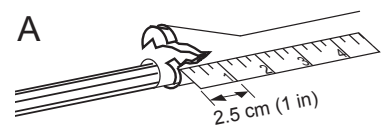

Step 2: Position the grounding clamp base plate under the armor. The stops of the clamp should just touch the outside of the armor and sheath. Tap the sheath above the ground clamp base to drive the teeth on the plate into the cable sheath.

Step 3: Position the top plate and lock nut on the outer sheath over the base plate. Tighten with a 3/8-in wrench so that the teeth on the upper plate are driven into the sheath.

Step 4: Wrap the grounding clamp and split portion of the cable sheath with vinyl tape.

Step 5: Place the eyelet on the ground wire over the stud on the base plate. Add a second lock nut and tighten using a 3/8-in wrench.

NOTE: Ground lead will be attached to end cap in a later step.

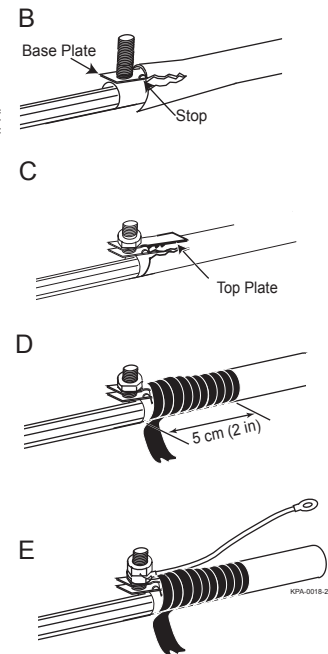

3.3 Install Express Strain-relief Hardware

Determine cable and strength member type and proceed accordingly:

- Strength members in single-tube cables must be separated by the restraint cap threaded stud.
- Single strength members in loose tube design cables must be secured in the cap.
- Strength members in cables (central tube) with sheath-mounted GRP (Glass Reinforced Plastic) need only the strength member(s) on one side of the cable secured in the cap.

3.3.1 Strain-relieve Non-metallic Strength Members

Install strain-relief bracket(s) onto the opposite side (180 degrees) from the grounding clamp, when applicable:

Step 1: Place a hose clamp over the cable and bracket 0.75 in (19 mm) below the sheath end.

IMPORTANT: If grounding hardware is used, make sure the hose clamp does not overlap the ground clamp.

Step 2: Tighten the hose clamp in the notch on the bracket with the tensioning body on the hose clamp on the same side of the bracket as the threaded stud. Tighten hose clamp to a torque value of 30 in-lb.

Step 3: Place a washer over the threaded stud on the strain-relief bracket.

Step 4: Wrap the yarn (if present) twice in a clockwise direction around the threaded stud.

Step 5: Install a washer and nut and tighten securely.

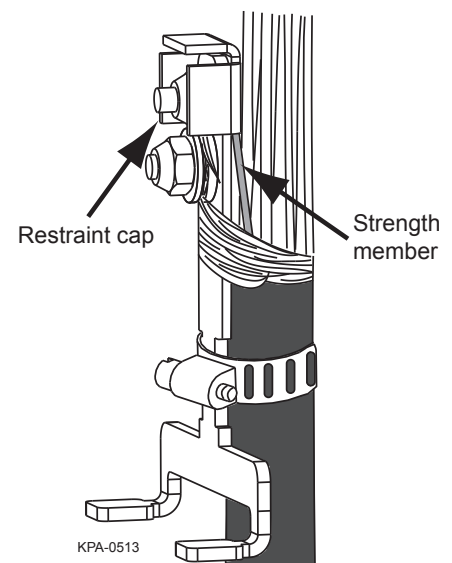
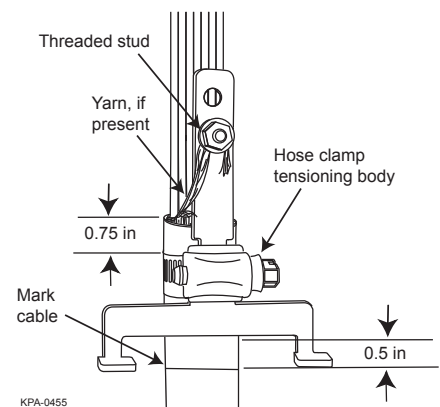

- Step 6:** Mark the cable in the location shown.
- Step 7:** Trim the strength member flush with the top of the strain-relief bracket.
- Step 8:** Insert the restraint cap threaded stud through the hole in the strain-relief bracket, capturing the strength member between the two.
- Step 9:** With the strength member behind the bracket, install a nut on the restraint cap threaded stud.
- Step 10:** Confirm buffer tubes are clear of the strength elements. Tighten nut securely.
- Step 11:** Repeat for the second cable, when applicable.

3.3.2 Strain-relieve Metallic Strength Members

If strength members are metallic:

- Step 1:** Bend them over the slots in the extension bracket as shown in the inset; then trim excess strength member.

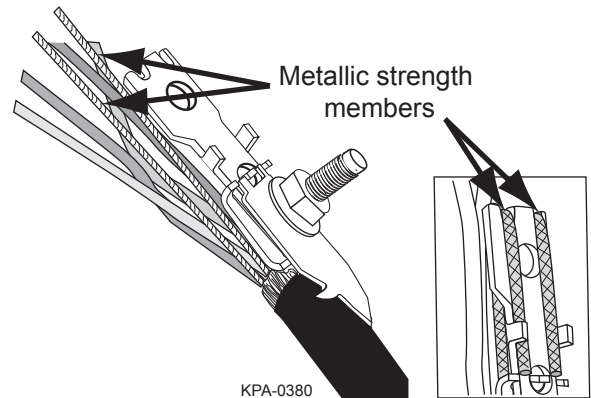

- Step 2:** Wrap the yarn, if present, twice in a clockwise direction around the restraint cap threaded stud.
- Step 3:** Install restraint cap in the orientation shown.
- Step 4:** Install a washer and nut. Tighten securely.
- Step 5:** Repeat for other cables, when applicable.

IMPORTANT: Confirm all buffer tubes are clear of the strength elements prior to securing the restraint cap.

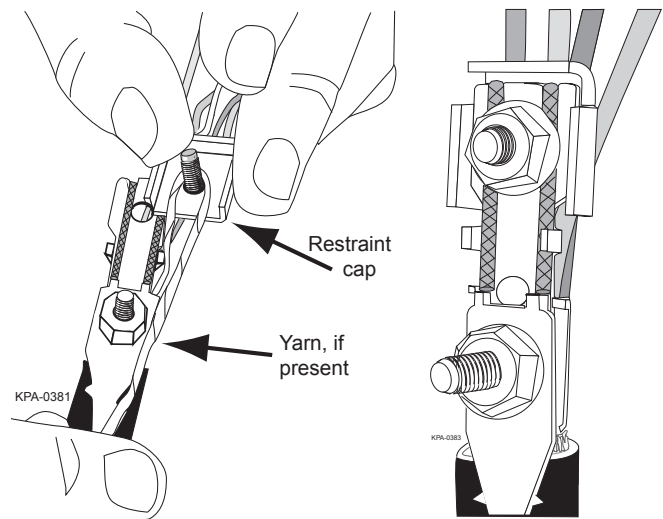

3.3.3 Strain-relieve Large Strength Members

For cables with large strength members, use the large central member strain-relief kit (p/n SCF-MBR-CMS-25, purchased separately for SCF-6C applications) instead of the restraint caps:

- Step 1:** Slide the metal barrel over the end of the central member.
- Step 2:** Align the threads in the side of the barrel with the hole in the top of the strain-relief bracket.
- Step 3:** Install the supplied screw through the threaded hole in the barrel.
- Step 4:** Tighten the screw.
- Step 5:** Trim the strength member flush with the top of the strain-relief bracket.

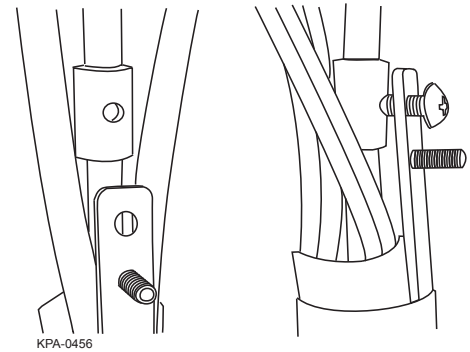

3.4 Install Cable into the End Cap Express Ports

NOTE: Use the two main cable ports in the center of the end cap first. Use the drop ports as needed.

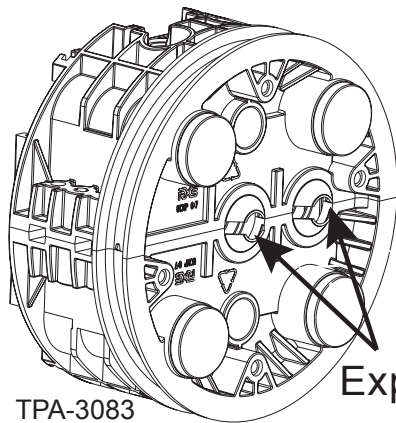

TPA-3083

Express Ports

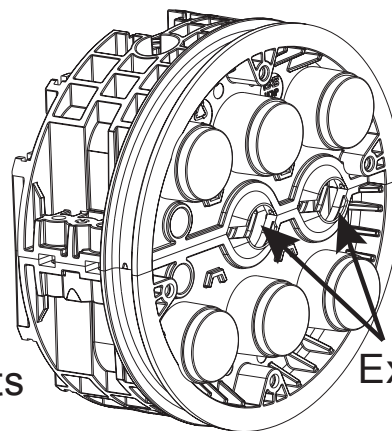

Express Ports

SCF-6 End Cap

SCF-8 End Cap

3.4.1 Prepare the End Cap

- Step 1:** Remove the frame from the end cap.
- Step 2:** Pull the end cap halves apart.
- Step 3:** Beginning with the inside of the end cap, apply sealing tape to the end cap half containing the metallic standoffs. Cut holes in the tape to expose the standoffs.

IMPORTANT: It is imperative that the strain-relief bracket have no contact with the tape. Make sure the strain-relief tracks on the inside of the end cap and the screw holes are not obstructed by the sealing tape.

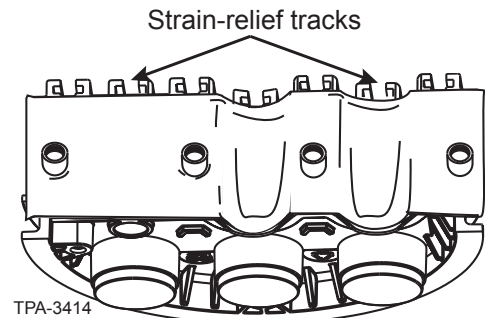

TPA-3414

3.4.2 Apply Sealing Tape to the Cable



CAUTION: Isopropyl alcohol is flammable with a flashpoint at 54°F. It can cause irritation to eyes on contact. In case of contact, flush eyes with water for at least 15 minutes. Inhaling fumes may cause mild dizziness. In case of ingestion, consult a physician.



CAUTION: Use sealing paste and cable cleaner in a well-ventilated area to eliminate the possibility of dizziness and nausea. If paste or cleaner comes in contact with skin or eyes, wash area immediately with soap and water to avoid irritation. Do not induce vomiting if paste cleaner is ingested.

Step 1: Clean the cable where the tape will be applied using the provided alcohol pad.

Step 2: Beginning at the mark shown, use wax-paper backing from the sealing tape to spread the “dichtpaste” sealing paste evenly around the cable in the area where the sealing tape will be applied. Allow the sealing paste to dry.

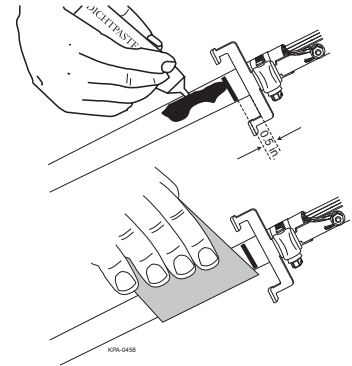

Step 3: Cut and pull the strip of sealing tape as shown. The tape will stretch and thin before it breaks.

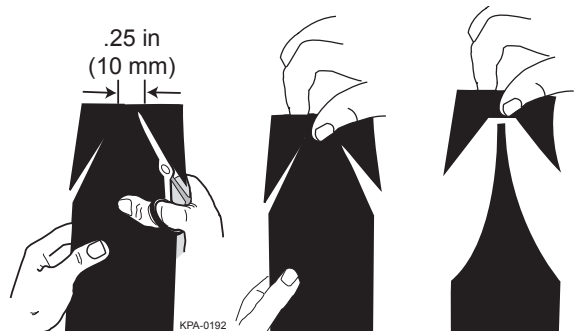

Step 4: Wrap the tape around the cable so that it doesn't extend above the mark shown until it fills the diameter “C” on the Combination Wrench Tool. Express ports will accommodate cable with a maximum diameter of 1.4 in (32 mm); some cables require only one wrap of sealing tape to reach this diameter. Always finish with a complete wrap that overlaps the starting point by approximately 0.5 in.

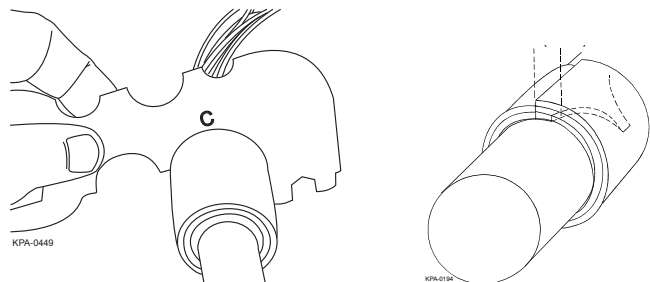

IMPORTANT: The combination wrench tool is used in several steps during the assembly process. Use only this tool for measuring and tightening components where indicated.

Step 5: Repeat Section 3.4.2 for the other cable to be installed in the express port, if applicable.

3.4.3 Install Cable

- Step 1:** Wrap hose clamps and restraint caps with vinyl tape to prevent the sharp edges from damaging the fiber.
- Step 2:** Place one side of the express cable sheath in the express port on the untaped end cap half by inserting the strain-relief bracket in the tracks.
- Step 3:** Place the other side of the express cable sheath on the taped end cap half in the center express port by inserting the strain-relief bracket in the tracks.

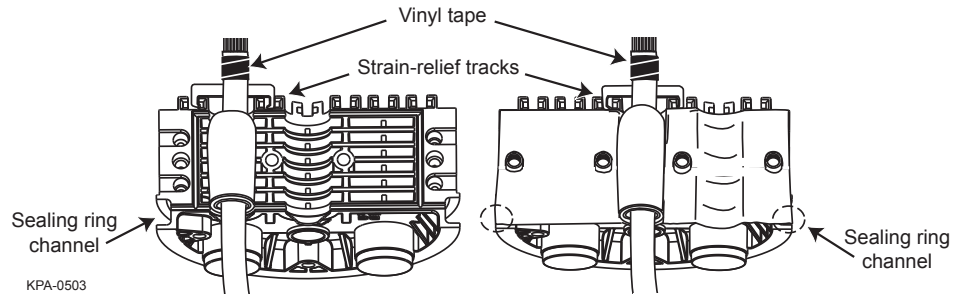

3.4.4 Use a Dummy Plug

When the closure only has one cable installed in the express ports, use a dummy plug (p/n SCF-4-6-PLUG, purchased separately) to fill the unused port.

- Step 1:** Follow instructions in Section 3.4.2 to install sealing paste and tape to dummy plug.
- Step 2:** Install dummy plug with the closed end of the plug flush against the outside of the end cap.

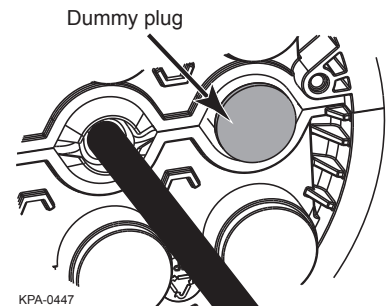

3.4.5 Close End Cap Halves

IMPORTANT: Do not use power tools to tighten the end cap.

- Step 1:** Place the upper end cap half over the lower end cap half.
- Step 2:** Install one short bolt and washer on each side of the end cap half.
- Step 3:** Install two long bolts and washers near the center of the end cap.
- Step 4:** Alternately tighten the bolts to close the end cap.

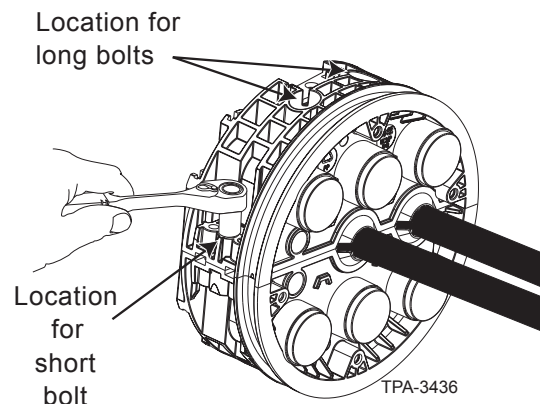

IMPORTANT: While tightening, ensure that the feet of the strain-relief brackets remain inside the tracks.

- Step 5:** Tighten the bolts until the end cap closing gauge (Section H of the combination wrench tool) fits over the sides and center measuring points of the end cap.
- Step 6:** Cut excess sealing tape from the sealing ring channel and strain-relief tracks (shown by dashed circles in the illustration accompanying Section 3.4.3) using scissors or side cutters.

NOTE: Do not pull or stretch sealing tape.

Step 7: Completely remove any remaining sealing tape inside the sealing ring channel with the blade of a screwdriver.

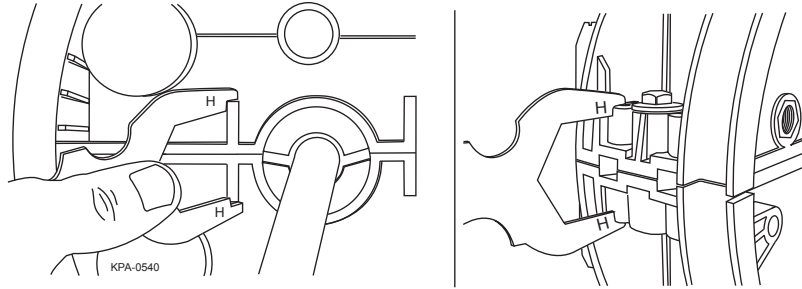

3.4.6 Install Vented Grounding Screw

Step 1: Apply a thin coat of UCN lubricant to the threads of the vented grounding screw.

Step 2: Install the vented grounding screw in the threaded insert on the inside of the end cap finger-tight plus one half turn (approximately 40 to 60 in-lb).

NOTE: Skip this step if installing drop cables at this time.

3.5 Ground Cable (Armored Cable Only)

Ground armored cable per local practices.

Remove the small insert from the vented grounding screw and attach previously installed grounding wire(s). Tighten the insert.

NOTE: If not installing drop cables at this time, reinstall the frame assembly using the two hex bolts removed previously and skip to Section 3.12.

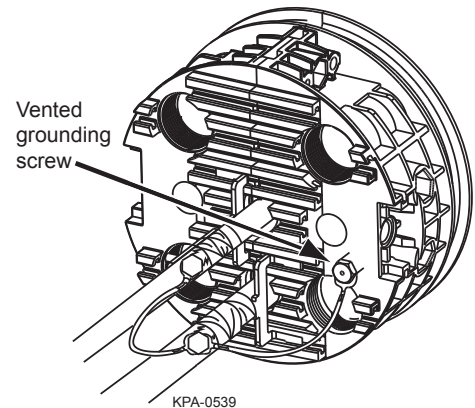

3.6 Prepare Drop Cable Port(s)

Step 1: Choose a cable port to be used and open the port using a hacksaw or a knife. Be careful not to damage the internal threads of the drop port while sawing.

IMPORTANT: Use either or both of the middle ports on the SCF-8 end cap first to make routing easier.

Step 2: Smooth the port opening using a utility or cable knife as shown.

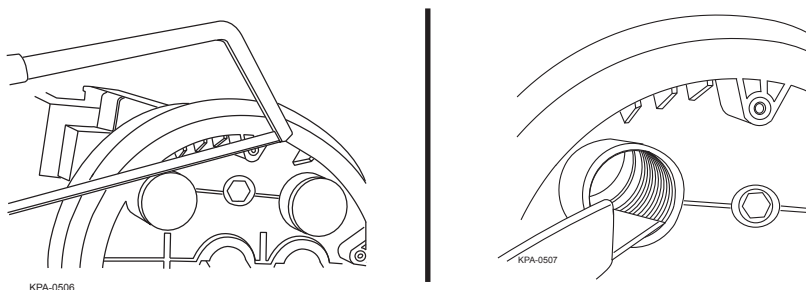

Step 3: Use the combination wrench tool to determine which size sealing grommet is required.

SCF6

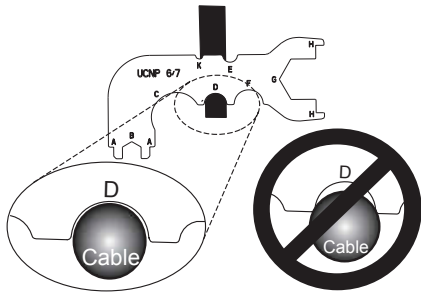

Cable Diameter Range:	If Cable Diameter Is:			Select Grommet Size
	Greater than or equal to:		Less than:	
18 mm ↑ 5 mm	Wrench Gauge "D"	AND	Wrench Gauge "F"	Large
	Wrench Gauge "E"	AND	Wrench Gauge "D"	Medium
	Wrench Gauge "K"	AND	Wrench Gauge "E"	Small
5 mm	Less than "K"	Cable is too small for sealing system.		
Flat	Requires P/N SCF-KT-G62-F Grommet kit (purchased separately)			

NOTE: Dimensions are for reference only.

SCF8

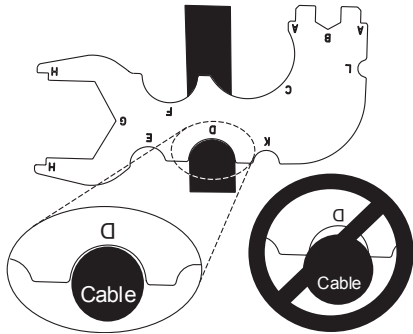

Cable Diameter Range:	If Cable Diameter Is:			Select Grommet Size
	Greater than or equal to:		Less than:	
25 mm ↑ 8 mm	Wrench Gauge "D"	AND	Wrench Gauge "F"	Large
	Wrench Gauge "E"	AND	Wrench Gauge "D"	Medium
	Wrench Gauge "K"	AND	Wrench Gauge "E"	Small
	Wrench Gauge "L"	AND	or equal to Wrench Gauge "K"	Smallest
8 mm	Less than "L"	Cable is too small for sealing system.		
Flat	Requires P/N SCF-KT-G84-F Grommet kit (purchased separately)			

NOTE: Dimensions are for reference only.

TPA-3100

Step 4: Place a toothed washer onto the sealing grommet and insert both into the opened port from the strain-relief side of the end cap. Verify correct placement of toothed washer on grommet.

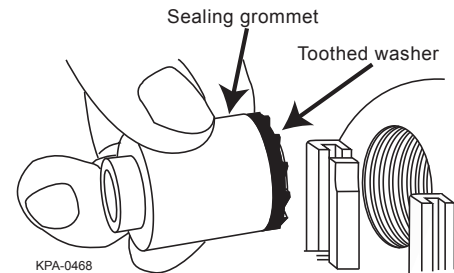

3.7 Install Drop Port Cable into End Cap

Step 1: Secure the sealing grommet and toothed washer with the lock nut on the inside of the end cap.

Step 2: Use Section A of the combination wrench tool to tighten the nut until it stops and is tight.

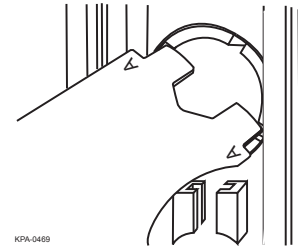

- Step 3:** Slide the compression screw over the cable.
- Step 4:** Slide the cable through the port.
- Step 5:** Prepare cable per Section 3.1. If the cable is armored, attach grounding hardware per Section 3.2.

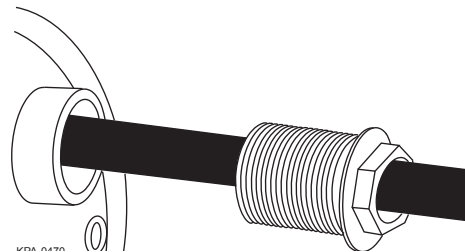

3.8 Strain-relieve Drop Port Cables

If installing SST-Drop™ cables in drop ports, refer to the instruction provided with the strain-relief kit (p/n SCF-KT-G62/84-F, purchased separately) for detailed instructions for strain-relieving the drop cables.

Install a drop port strain-relief bracket onto each drop port cable on the opposite side of the cable (180 degrees) from the ground clamp when applicable:

- Step 1:** Pull the cable approximately 12 in away from the end cap to ease bracket installation.

IMPORTANT: Secure the cable to the side of the bracket opposite the threaded stud.

- Step 2:** Place a hose clamp over the cable and bracket 0.75 in (19 mm) below the sheath end.

IMPORTANT: If grounding hardware is used, make sure the hose clamp does not overlap the ground clamp.

- Step 3:** Tighten the hose clamp in the notch on the bracket with the tensioning body on the hose clamp on the same side of the bracket as the threaded stud. Tighten hose clamp to a torque value of 30 in-lb.

IMPORTANT: Tighten hose clamp on SST-Drop cables to a torque value of 20 in-lb.

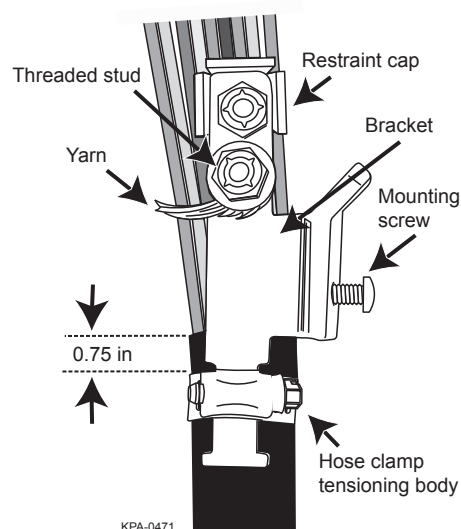

- Step 4:** Trim strength member flush with the top of the bracket.
- Step 5:** Insert the restraint cap threaded stud through the hole in the strain-relief bracket, capturing the central strength member between the two.
- Step 6:** Install a washer and nut onto the restraint cap stud and tighten securely.
- Step 7:** Wrap the aramid yarn, if present, twice in a clockwise direction around the threaded stud on the bracket.
- Step 8:** Install a second washer and nut and tighten securely.

IMPORTANT: Ensure that all buffer tubes are cleared from beneath the strength member prior to tightening the restraint cap.

- Step 9:** Wrap hose clamp and restraint cap with vinyl tape to prevent the sharp edges from damaging the fiber.
- Step 10:** Repeat Sections 3.5 - 3.7 for all drop cables.

3.9 Complete Frame Assembly

Reattach the frame assembly to the end cap.

3.10 Attach Strain-relief Bracket

- Step 1:** Pull the cable back to the end cap.
- Step 2:** Center the cable over the port and slide the attached screw on the strain-relief bracket into the slot on the metal frame.
- Step 3:** Tighten the strain-relief bracket mounting screw.
- Step 4:** Repeat Steps 1-3 for all drop cables.

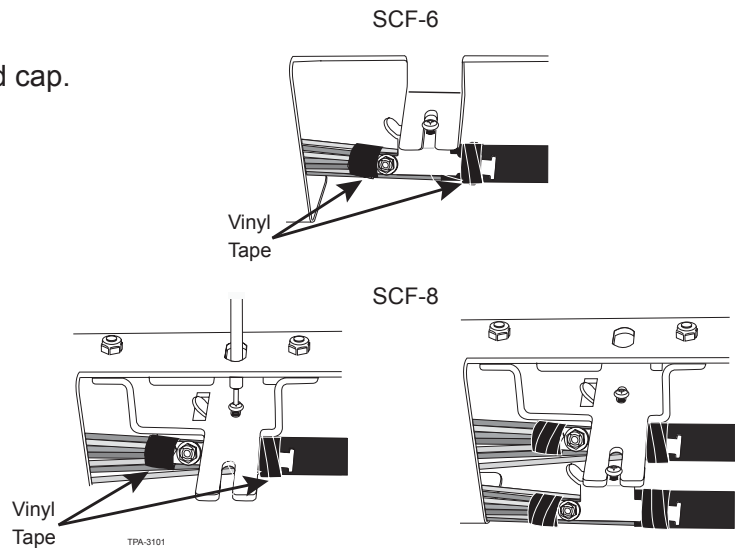

3.11 Tighten End Cap Compression Screw

Secure compression screw into end cap. Tighten with Section G of the combination wrench tool until the clicking sound stops or the screw is butted against the end cap.

IMPORTANT: DO NOT overtighten the screw.

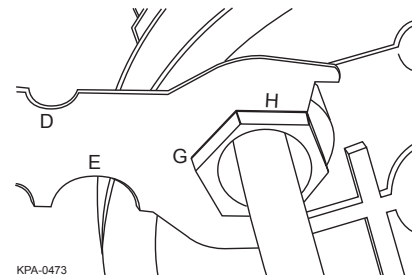

3.12 Splice

3.12.1 Prepare Fiber for Splicing

- Step 1:** Place an empty splice tray into the stacker assembly with the tray butted against the fiber management assembly.

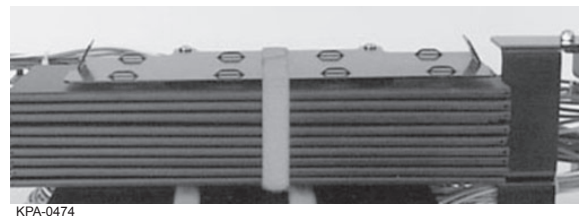

IMPORTANT: If installing into a U-bar Canister, center the trays in the stacker so that the hole in the tray aligns with slots on top and bottom of the U-bar.

- Step 2:** Select the buffer tubes to be spliced in this splice tray and route the buffer tube(s) past the rear of the splice tray stacker.
- Step 3:** Curve the buffer tubes past the inside of the adjuster bracket or splice tray stacker, as applicable. Place the buffer tube(s) next to the corner of the splice tray.
- Step 4:** Use a permanent marker to mark the buffer tube 0.75 in (19 mm) from the corner of the splice tray.
- Step 5:** Remove the buffer tube at the mark made in the previous step.
- Step 6:** Clean fibers according to cable manufacturer's instructions.

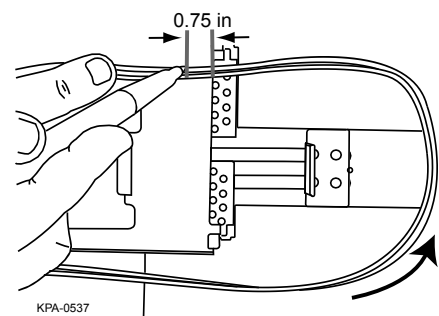

- Step 7:** Secure the buffer tube to the tray per instructions provided with the splice tray. (If installing in a U-bar frame, ensure the hole in the tray aligns with the slots on the U-bar frame before securing the buffer tube to the tray.)
- Step 8:** Prepare any other splice trays the same way.
- Step 9:** When all trays are prepared, splice per local practice.

3.12.2 Store Cable Slack

Loop any unspliced (or express) buffer tubes inside the slack basket.

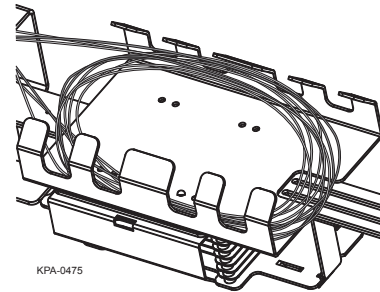

3.12.3 Secure Spliced Trays

SCF-6C and SCF-8C Canister Closures

- Step 1:** Place the spliced trays into the tray stacker. Make sure the buffer tubes are within the flange on the tray stacker as shown.
- Step 2:** Secure the buffer tubes using cable ties as needed.
- Step 3:** Store the combination wrench tool between the splice tray stacker and the frame.
- Step 4:** Secure all buffer tubes, splice trays and the combination wrench using the hook-and-loop straps.
- Step 5:** Position the wrench so that it does not interfere with the dome cover during installation.
- Step 6:** Reposition the adjuster bracket to keep the trays from moving, if necessary.

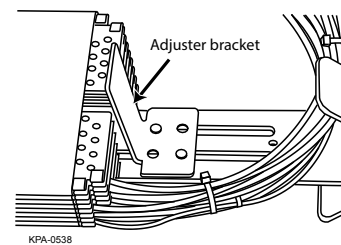
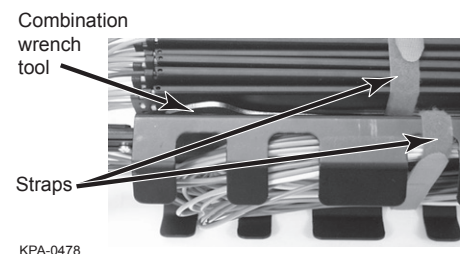

SCF-6C and SCF-8C U-bar Canister Closures

- Step 1:** Align the holes in the splice trays with the slots on the top and bottom of the U-bar.
- Step 2:** Insert the threaded rod through the slot on the top of the U-bar, through the hole in the splice trays and through the slot on the other side of the U-bar. Install a wing nut (from the accessory kit) onto the end of the threaded rod.
- Step 3:** Secure all buffer tubes within the U-bar frame using the hook-and-loop strap.

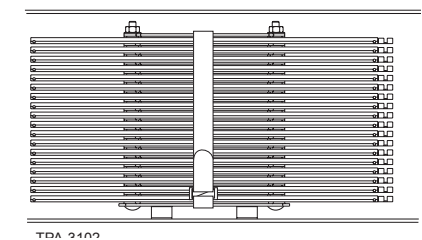

NOTE: To increase splice tray capacity, remove the tray stacker assembly and retain the trays using the threaded rod and hook-and-loop strap. This option eliminates single tray access.

3.13 Seal the Canister Closure

NOTE: Do not use liquid encapsulant in SCF closures.

3.13.1 Install Seal

Step 1: Roll the sealing ring over frame and down to the end cap with arrows as shown.

IMPORTANT: The sealing ring must be installed in the orientation shown.

Step 2: Verify there is no sealing tape in the sealing ring channel. Flatten any sealing tape with a slotted screwdriver.

Step 3: Use the supplied brush to apply a third of the UCN lubricant tube to the sealing ring channel on the end cap.

Step 4: Stretch the sealing ring over the channel.

Step 5: Fold the edge of the seal that overlaps the outside of the end cap until the seal seats in the channel as shown.

IMPORTANT: The installed sealing ring must be oriented as shown with the arrows pointing towards the incoming cable. .

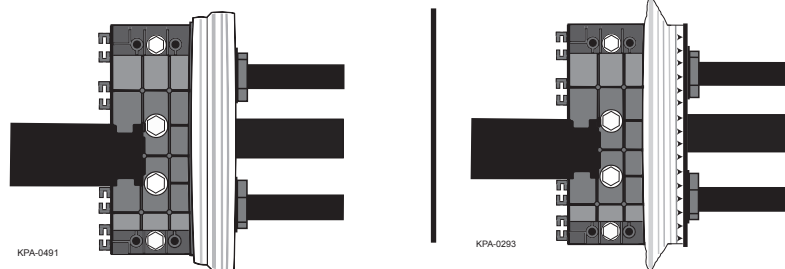
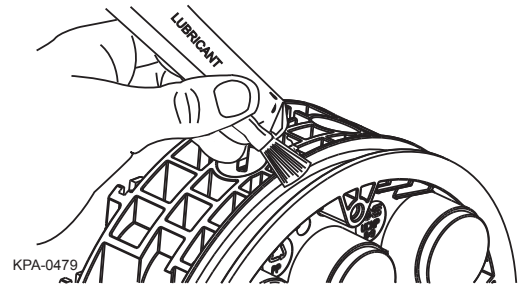
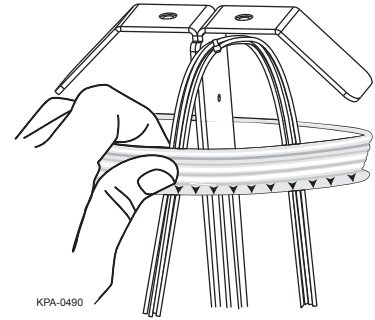

Step 6: Retain a small amount of UCN lubricant for use later. Apply the remaining lubricant to all sides of the sealing ring.

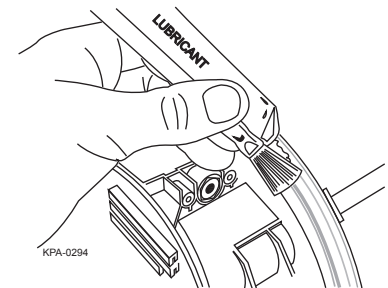

3.13.2 Install the Canister Cover

Step 1: Slide the canister over the closure assembly.

Step 2: Loosen both bolts on the clamping ring.

Step 3: Apply a thin coat of UCN lubricant retained previously to the threads of the clamping ring latch bolts to prevent the bolts from seizing on reentry.

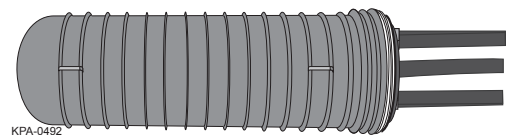

Step 4: Place the clamping ring over the flange of the canister and the sealing ring with the embossed lettering toward the outside of the closure. Ensure that both the sealing ring and the canister flange are within the clamping ring.

NOTE: The clamping ring seams must be oriented 90 degrees from the end cap seam.

Step 5: Swing the clamping ring into closing position. Tighten the bolts until the plastic on the ring touches, then torque to a 50 in-lb value.

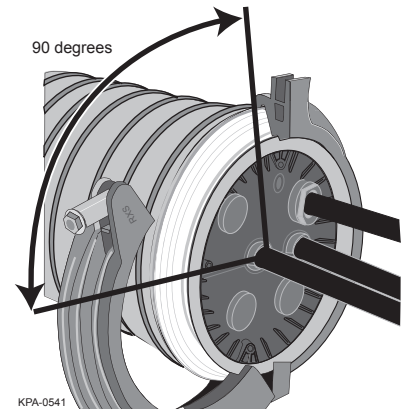

IMPORTANT: A torque value of 50 in-lb should be sufficient. Do not use power tools to tighten the clamping ring; a torque value of more than 80 in-lb causes the hardware to crack and the clamping ring to become defective. If the clamping ring does not close properly, make sure the sealing ring and clamping ring are oriented correctly.

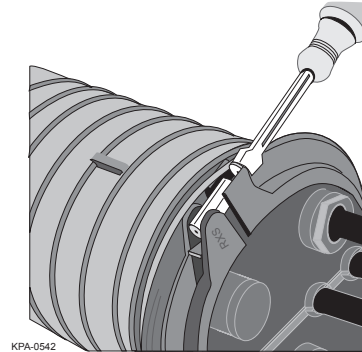

3.14 Install a Flash Test Air Valve

3.14.1 Install Valve Stem

Step 1: Apply a thin coat of UCN lubricant retained previously to the threads of the valve stem (p/n UCN-KT-FV, package of five, purchased separately).

Step 2: Install the valve stem finger-tight, then another half turn with a wrench, into the grounding port as shown.

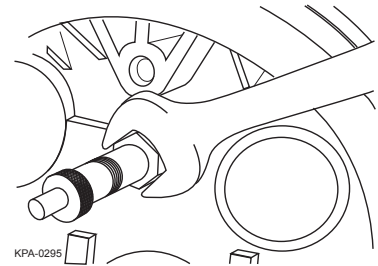

3.14.2 Perform Flash Test

Step 1: Inject 12 to 14 psi of air into the closure using a hand pump. Check pressure regularly.



WARNING: To avoid a potentially hazardous situation that could result in death or serious injury, do not exceed 14 psi (100 kpa) gauge pressure. The closure could burst.

Step 2: Apply soapy water to the seal points and watch closure for signs of leakage (bubbling of soap). A correctly sealed closure maintains pressure with no leaks.

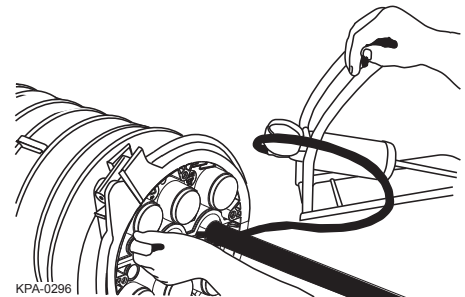

Step 3: After the flash test has been performed and the closure sealed correctly, carefully release pressure, remove the air valve and allow air to escape.

Step 4: Apply a thin coat of UCN lubricant retained previously to the threads of a solid, two-piece non-vented grounding screw.

Step 5: Install the screw into the end cap from the outside of the end cap finger-tight, then another half turn (approximately 40 to 60 in-lb).

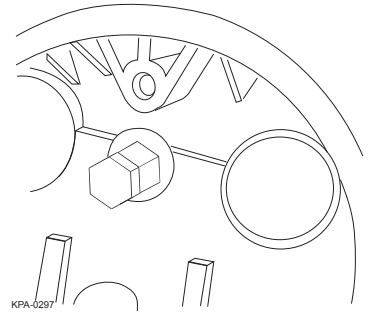

3.15 Ground the Closure

Step 1: Remove the smaller insert from the grounding screw.

Step 2: Connect a grounding cable (not supplied) to the screw.

Step 3: Screw the smaller insert back into the screw.

Step 4: Tighten the insert using a small adjustable wrench.

Step 5: Terminate the other end of the ground per local practices.

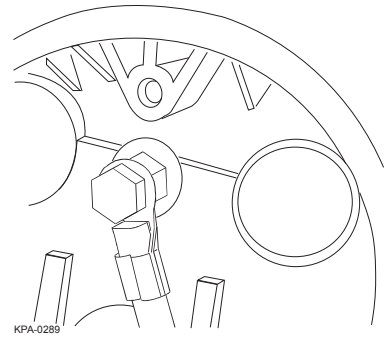

3.16 Reenter the Canister Closure

Step 1: If it is necessary to reenter the canister closure, verify there is no pressure by removing external ground screw and allowing air to escape.

Step 2: Remove clamping ring by untightening the two bolts.

Step 3: Perform any tests, modifications or examinations of the closure that are necessary.

Step 4: Reinstall the clamping ring per Section 3.13.2.

Step 5: Flash test closure per Section 3.14 on every entry.

Step 6: Re-terminate the grounding cable, if applicable, per Section 3.15.

3.17 Reopen the End Cap

Step 1: Reenter the closure as described in Section 3.15.

Step 2: Separate the frame from the end caps by removing the two bolts.

Step 3: Remove the end cap sealing ring.

Step 4: Remove the two long and two short bolts holding the end cap segments together.

Step 5: Insert a slotted screwdriver in the square opening on either side of the end cap to help pry open the end cap segments.

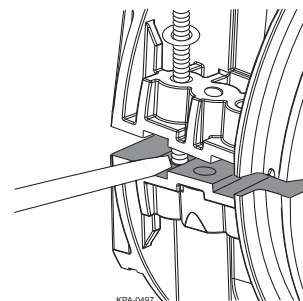
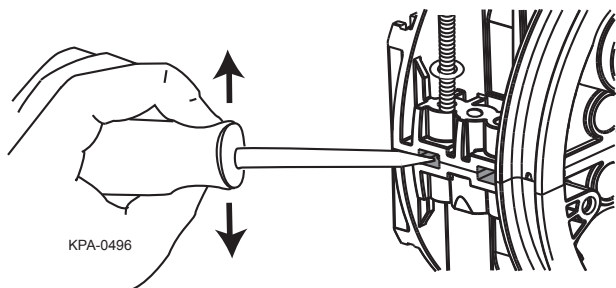

Step 6: Remove any sealing tape from inside the square opening on either side of the end cap where the bolts will be inserted to prevent the threads of the bolt from becoming clogged.

Step 7: Insert one of the long bolts into either hole that has a threaded insert (next to the outer closing holes) as shown.

Step 8: Tighten the long bolts on either side of the end cap while holding the screwdriver in place.

Step 9: Alternate tightening the bolts until the end cap halves are fully separated.

IMPORTANT: Do not use power tools to separate the end caps.

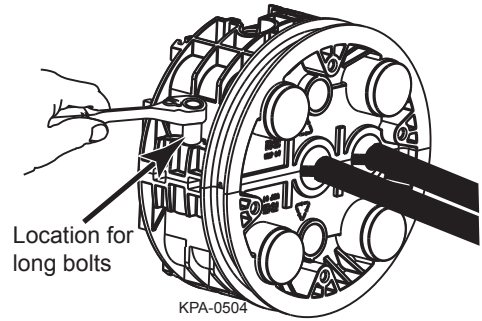

Corning Optical Communications LLC • PO Box 489 • Hickory, NC 28603-0489 USA
800-743-2675 • FAX: 828-325-5060 • International: +1-828-901-5000 • www.corning.com/opcomm

Corning Optical Communications reserves the right to improve, enhance, and modify the features and specifications of Corning Optical Communications products without prior notification. A complete listing of the trademarks of Corning Optical Communications is available at www.corning.com/opcomm/trademarks. All other trademarks are the properties of their respective owners. Corning Optical Communications is ISO 9001 certified. © 1999-2002, 2005-2006, 2010-2011, 2014-2015 Corning Optical Communications. All rights reserved. Published in Mexico.
