

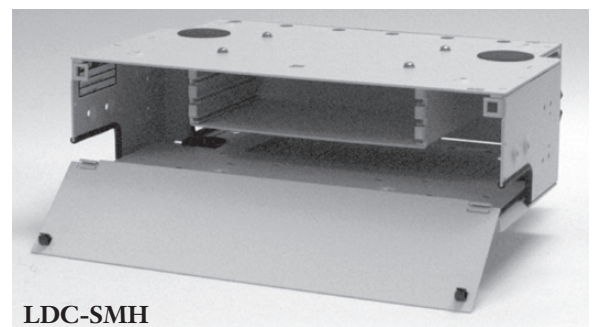

Table of Contents

1.	General	1
2.	Carton Contents	1
3.	Tools and Materials Required	1
3.1	Tools	1
3.2	Materials	2
4.	Installation	2
4.1	Mount the Housing into a Rack	2
4.2	Mount the Housing to a Wall	2
4.3	Secure the Cable	2
4.3.1	Strain-relieving The Cable Using the Universal Cable Clamp (UCC)	2
4.3.2	Strain-relieving the Cable Central Member	3
5.	Managing Cable	3
5.1	Prepare Cable for Splicing	3
5.2	Splice the Fibers in LDC-SMH Housing	4
5.3	Splice Fibers in the LDC-SMH-216 Housing	4
5.4	Replace Doors (If They Were Removed)	4
6.	Maintenance	5

1. General

This document describes the recommended procedure for installing the LDC-SMH Splice Module Housing. The LDC-SMH units accept Lucent™ LTIA-type splice trays (purchased separately). Use sheath termination hardware kits and connectorization arrays supplied by Lucent.



2. Carton Contents

Hardware quantities may vary depending on the unit ordered. Generally, most cartons contain:

- (1) Splice Module Housing
- (2) Mounting brackets
- (4) 10-32x0.375 slotted hex-head screws
- (2) 10-32x0.375 Phillips-head screws
- (2) 10-32 Hex nuts
- (4) 2x3-4X0.03 Flat washers
- (10) #10 Flat washers
- (4) 10-32x0.3125 Phillips-head screws

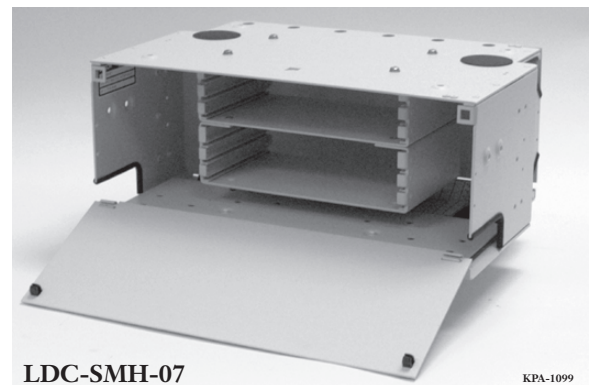

KPA-1099

Figure 1

- (17) 0.75-inch Circular routing clips
- (1) Universal Cable Clamp (UCC) bracket
- (2) 10-32x0.5 Phillips-head screws
- (1) Universal Cable Clamp kit
- (4) 12-24x0.5 Phillips-head screws

**LDC-SMH
LDC-SMH-07**

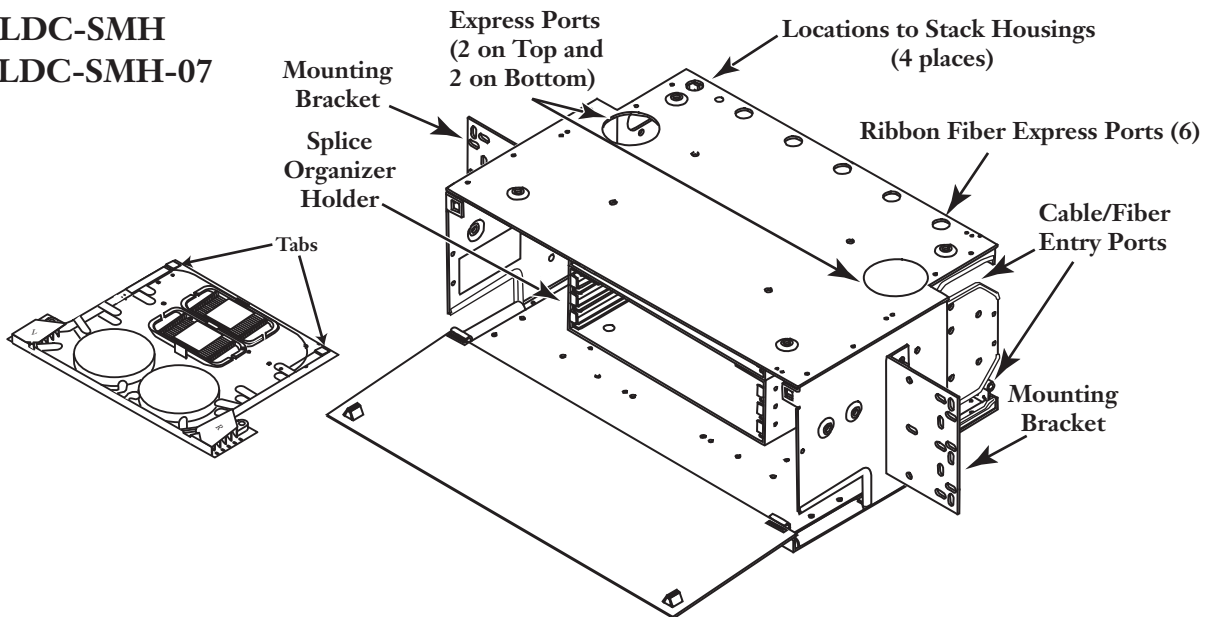

LDC-SMH-216

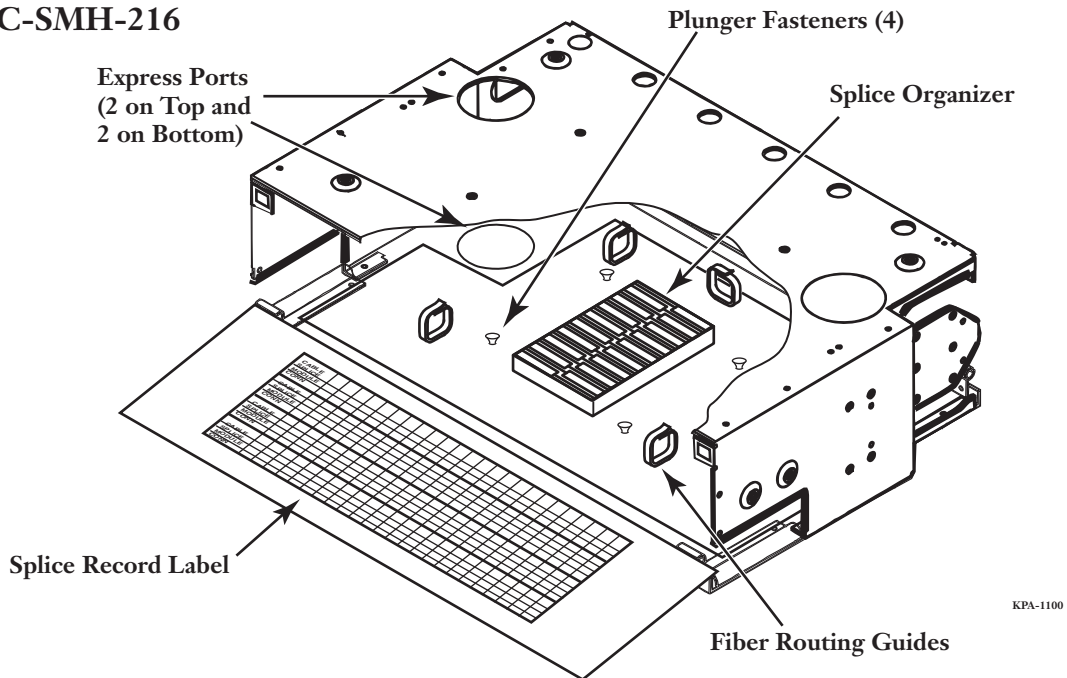

KPA-1100

Figure 2

3. Tools and Materials Required

3.1 Tools

- Phillips-head screwdriver
- Flat-tipped screwdriver
- 5/32-inch socket or wrench
- Needle-nosed pliers
- Cable stripping tools

3.2 Materials

- A ribbon fan-out kit (purchased separately) is required when installing ribbon fiber.
- Mounting hardware is not included. The type of hardware used is dependent upon the mounting location; wall anchors may be required for adequate support on sheetrock walls. Mount directly to wall studs when possible.

4. Installation

4.1 Mount the Housing into a Rack

IMPORTANT: Remove the express port plugs from the bottom and top of the housing before mounting the housing into the rack.

Attach the brackets to the housing using the provided 10-32x0.5-inch screws (Figure 3). Attach the unit to the equipment rack using the four screws provided (two screws per side).

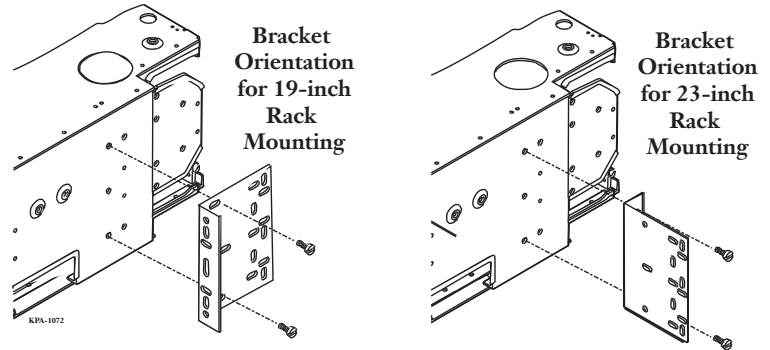

Figure 3

The mounting bracket position may be changed to adjust the frontal projection from the rack. The unit can also be mounted to the front of the rack uprights (Figure 4).

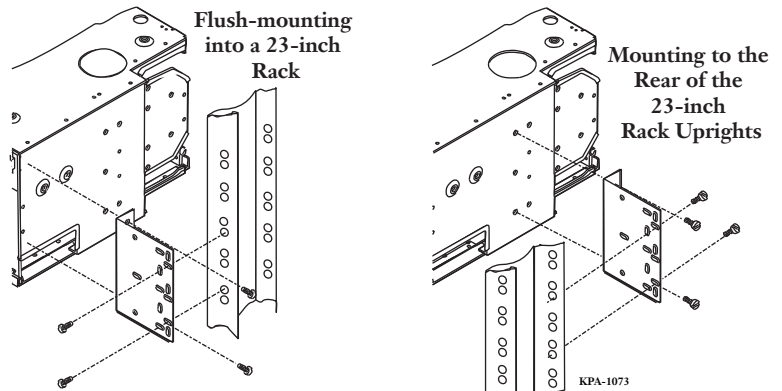

Figure 4

4.2 Mount the Housing to a Wall

Make sure the rear door is attached. Attach mounting brackets to the housing as shown (Figure 5). Select a flat vertical surface to prevent warping. Make sure the wall will support the weight of the unit; wall anchors may be required in sheetrock walls. Mount the unit to the wall studs when possible. Hardware to secure the unit to the wall is not provided.

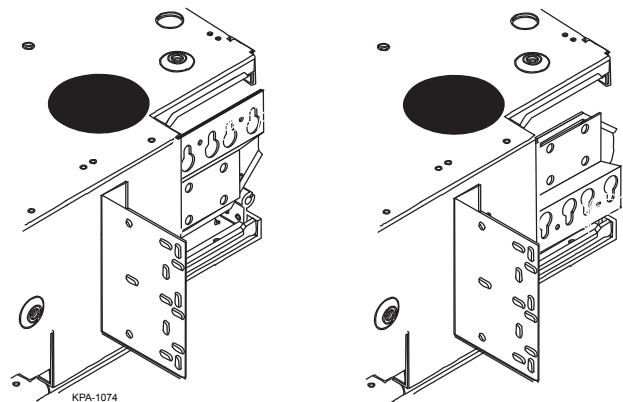

Figure 5

4.3 Secure the Cable



CAUTION: Fiber optic cable is sensitive to excessive pulling, bending, and crushing forces. Consult the cable specification sheet for the cable you are installing. Do not bend the cable more sharply than the minimum recommended bend radius. Do not apply more pulling force to the cable than specified. Do not crush the cable or allow it to kink. Doing so may cause damage that can alter the transmission characteristics of the cable; the cable may have to be replaced.



CAUTION: If you are installing outside plant cable or temperature fluctuates widely along any part of the cable, the central member must be strain-relieved. Failure to do so may result in damage to the cable as temperature varies. If the entire length of cable is located in a controlled environment where temperature fluctuation is minimal, it is not necessary to secure the central members. The cable can be strain-relieved by sheath retention alone..

To strain-relieve the cable, use the Universal Cable Clamp (UCC) or cable ties.

4.3.1 Strain-relieving The Cable Using the Universal Cable Clamp (UCC)

Step 1: Determine the location for cable entry into the housing and install bracket in the orientation shown for cable entry from that direction (Figure 6).

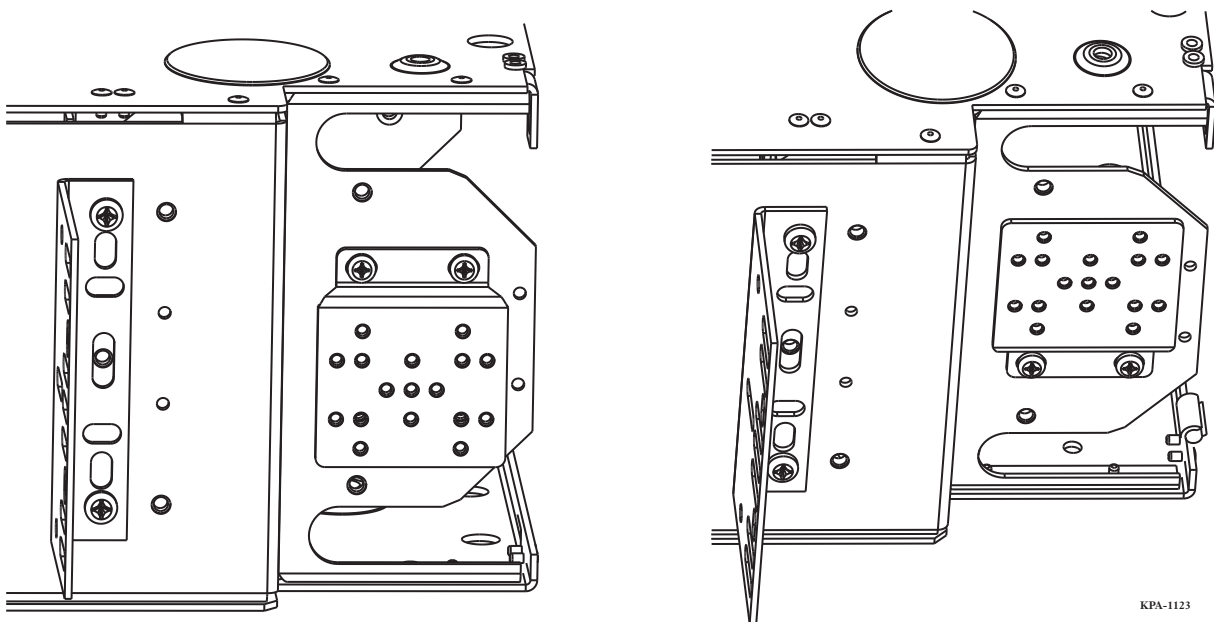

Figure 6

Step 2: Attach the UCC clamshell to the strain-relief bracket as shown in Figure 7.

Step 3: Attach the strain-relief bracket to the housing (Figure 7).

Step 4: Follow installation instructions provided with the UCC kit to secure the cable. Do not tighten yet to allow for cable adjustment if necessary.

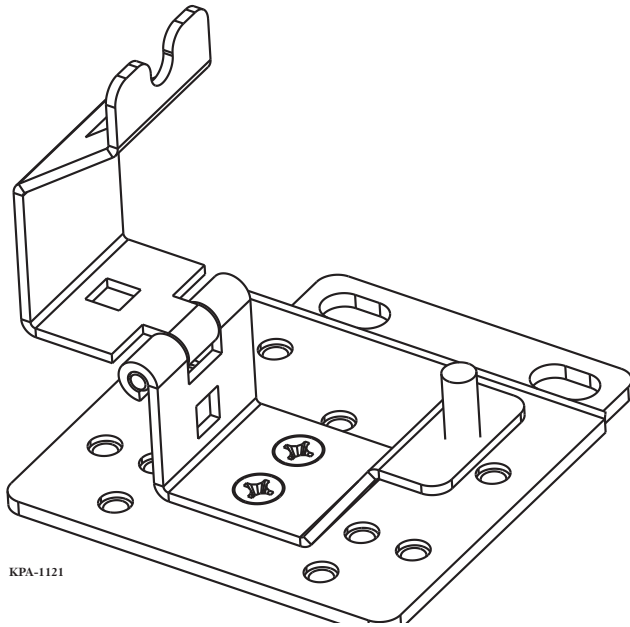

Figure 7

4.3.2 Strain-relieving the Cable Central Member



CAUTION: Corning recommends the use of safety glasses (spectacles) conforming to ANSI Z87 for eye protection from accidental injury when handling chemicals, cables, or working with fiber. Pieces of glass fiber are very sharp and have the potential to damage the eye.



CAUTION: The wearing of cut-resistant safety gloves to protect your hands from accidental injury when using sharp-bladed tools and armored cable is strongly recommended. Use extreme care when working with severed armor. There will be a sharp edge where armor is cut. To minimize the chance of injury from the cut armor, cover the exposed edge with a wrap of electrical tape. To minimize the chance of injury from sharp-bladed tools, always cut away from yourself and others. Dispose of used blades and armor scrap properly.

- Step 1:** Install the U-shaped washer and the flat washer on the supplied Phillips-head machine screw into the side of the housing in the orientation shown. Install the screw into the side of the housing.
- Step 2:** Loosely install the hex nut.
- Step 3:** Place the central member and yarn, if present, between the U-shaped washer and the flat washer.
- Step 4:** Wrap yarn around the screw in a clockwise direction and under the U-shaped washer (Figure 8).
- Step 5:** Tighten the hex nut.
- Step 6:** Trim off the excess yarn.
- Step 7:** Trim the central member to less than or equal to 6.5 cm (2 1/2 inches) from the end of the cable sheath.

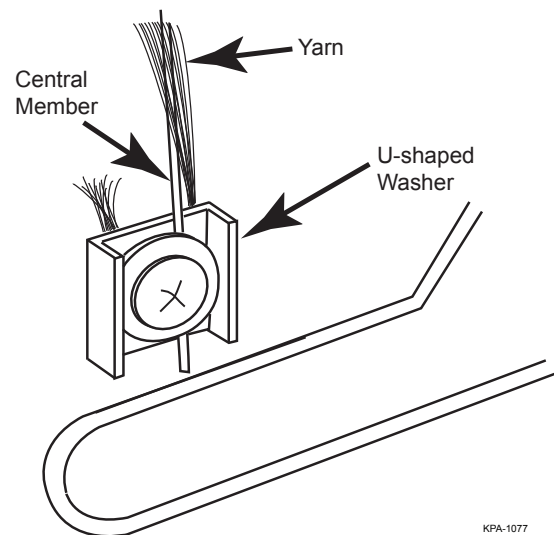

Figure 8

5. Managing Cable



WARNING: Never look directly into the end of a fiber that may be carrying laser light. Laser light can be invisible and can damage your eyes. Viewing it directly does not cause pain. The iris of the eye will not close involuntarily as when viewing a bright light. Consequently, serious damage to the retina of the eye is possible. Should accidental eye exposure to laser light be suspected, arrange for an eye examination immediately.



WARNING: DO NOT use magnifiers in the presence of laser radiation. Diffused laser light can cause eye damage if focused with optical instruments. Should accidental eye exposure to laser light be suspected, arrange for an eye examination immediately.

The front and rear doors can be removed to ease fiber installation. Turn the latch one-quarter turn and slide the doors to the side and off the hinges.

5.1 Prepare Cable for Splicing

Remove cable sheath according to the instructions provided with the cable. Suggested strip lengths are illustrated in (Figure 9). Do not expose the bare fiber until you are ready to terminate it.

NOTE: When using ribbon cable, refer to the instruction provided with the ribbon cable fan-out (purchased separately) for ribbon fiber lengths.

Single Fiber (with Buffer Tubes)

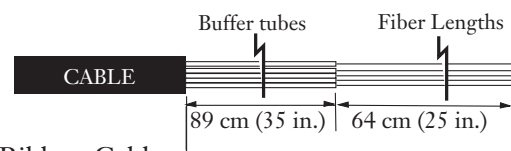

Ribbon Cable

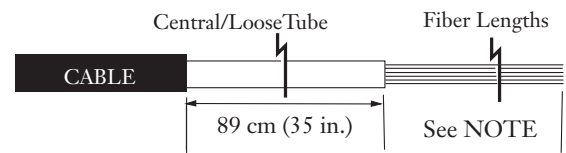

KPA-1101

Figure 9

5.2 Splice the Fibers in LDC-SMH Housing

Splicing can be done with the splice tray in place on the slide shelf or completely removed from the housing. To remove the splice tray, pull the slide shelf out as far as possible and press down on the plastic tabs at the back of the tray (Figure 10).

Step 1: Feed the pigtail fiber from the connector housing through the appropriate express port and into the splice housing (Figure 11).

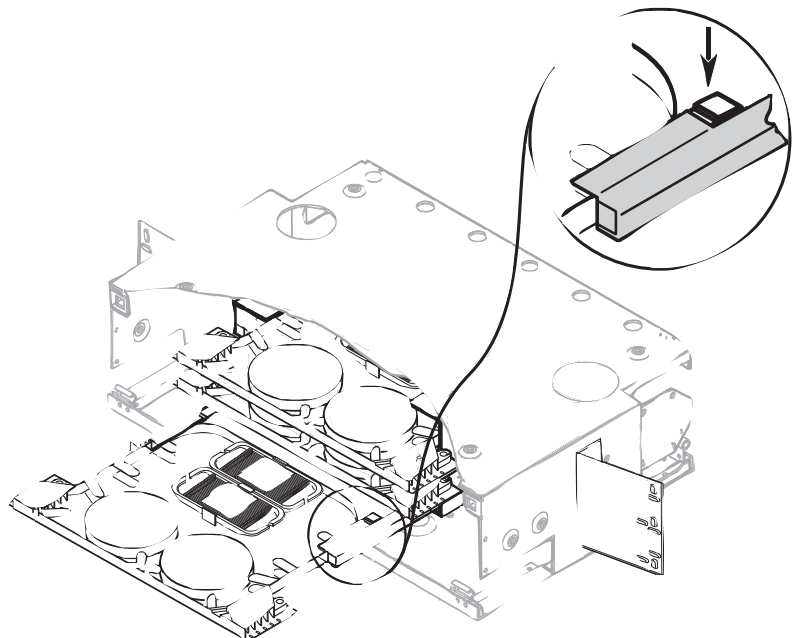

Figure 10

IMPORTANT: Make sure the end of each pigtail has an identification tag indicating the panel or module to which it is attached. If it is necessary to remove any excess length of pigtail fiber, place new identification tags on the working length prior to removing the excess. Each tight-buffered cable is color coded, but the sub-unit must have an identification tag.

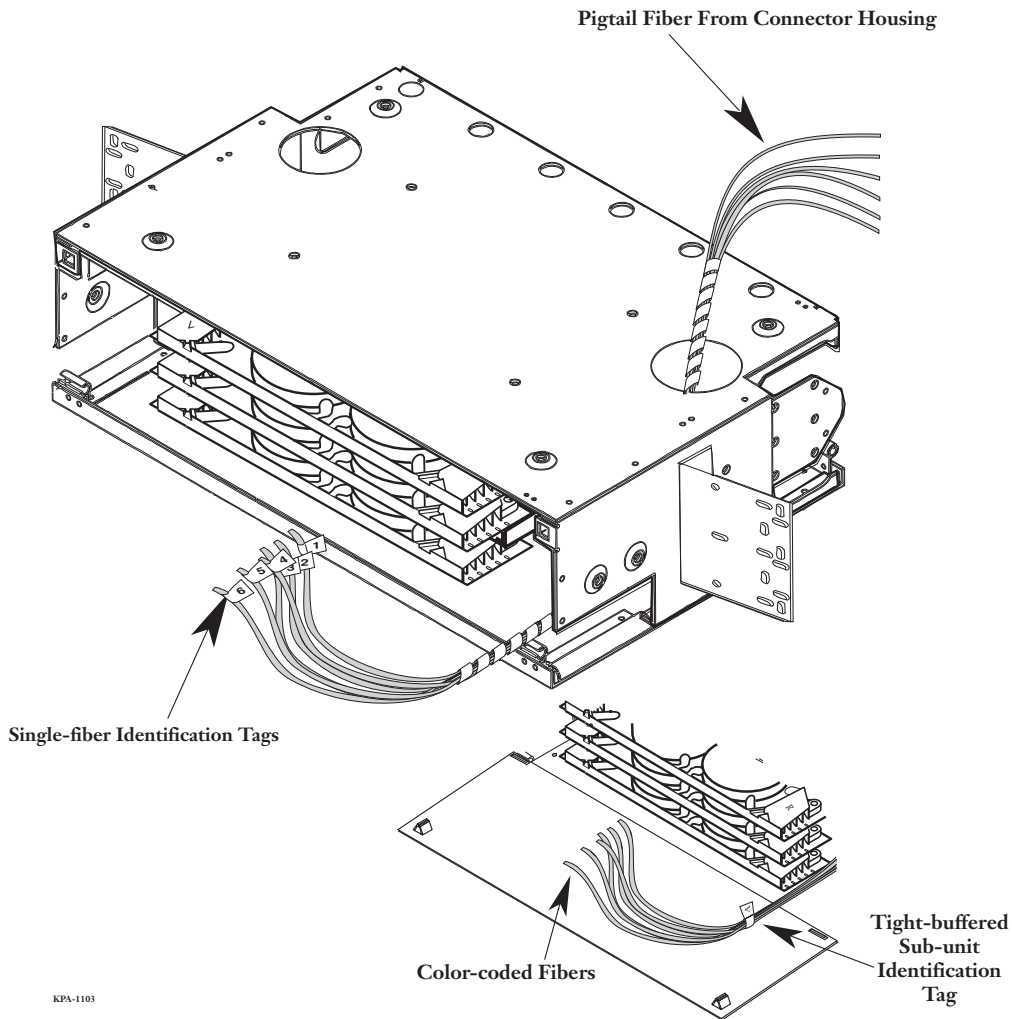
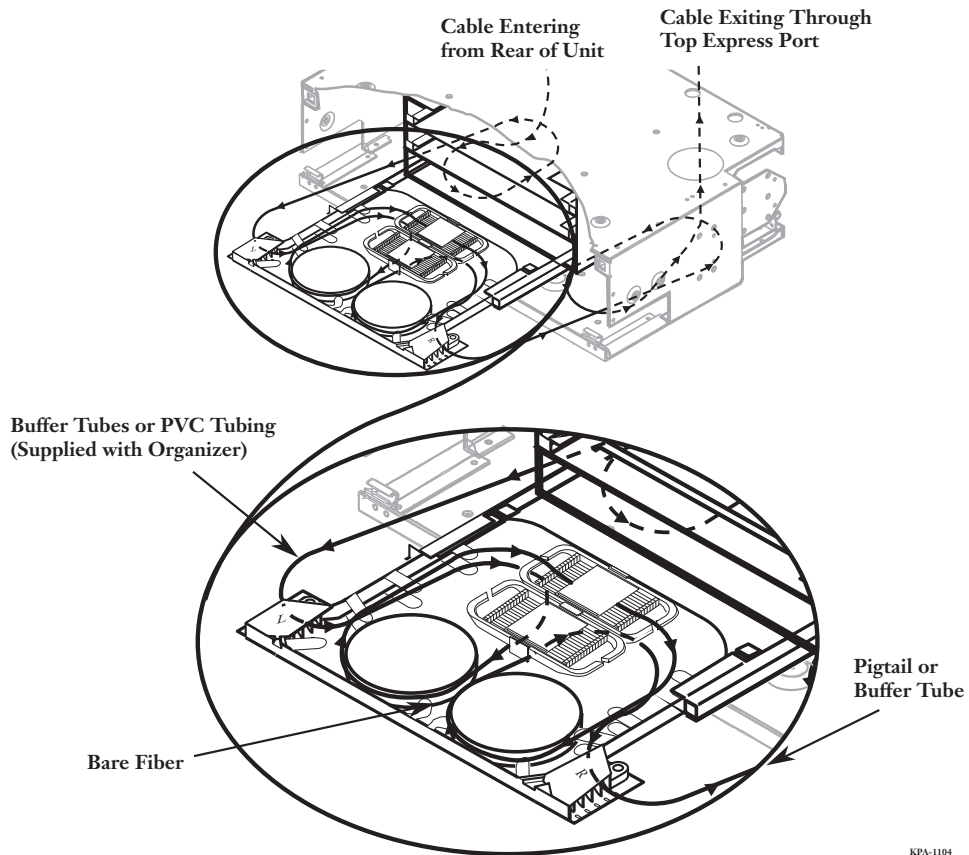

Figure 11

- Step 2:** Secure the pigtails to the entry ports of the splice tray using cable ties as described in the instruction provided with the tray.
- Step 3:** Secure the other cable to be spliced to the entry point of the tray using cable ties as described in the instruction provided with the tray.
- Step 4:** Coil two loops of fiber around the radius guides on the splice tray. Store excess fiber slack in the bottom of the housing as shown (Figure 12)
- Step 5:** Splice the fibers according to the instructions provided with the splicing equipment and according to the instruction provided with the splice tray.
- Step 6:** Record splice information as described in the instruction provided with the tray.

IMPORTANT: Accurate recordkeeping is imperative to an organized installation.

- Step 7:** Slide the splice tray onto the shelf. Secure using the tabs on the tray.



KPA-1104

Figure 12

5.3 Splice Fibers in the LDC-SMH-216 Housing

- Step 1:** Remove the splice platform by pulling up on the plunger fasteners.
- Step 2:** Install the fiber routing clips into the platform (Figure 13).
- Step 3:** Remove the cover from the splice organizer and set and the screws aside.

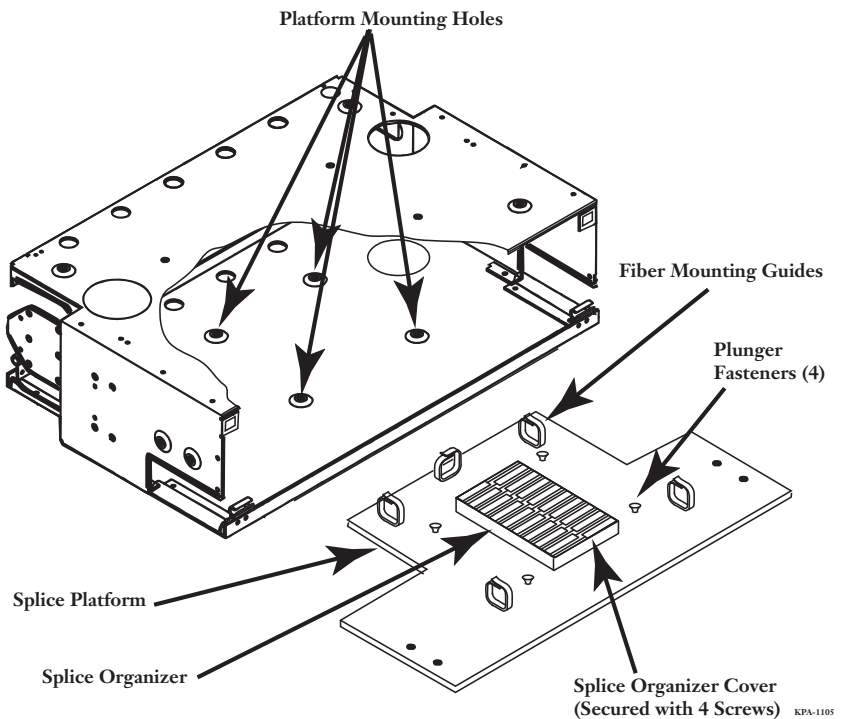

KPA-1105

Figure 13

Step 4: Route the ribbon fibers to be spliced to the splice platform as shown in Figure 14.

Step 5: Splice the fibers according to the instructions provided with the splicing equipment and according to the instruction provided with the splice platform.

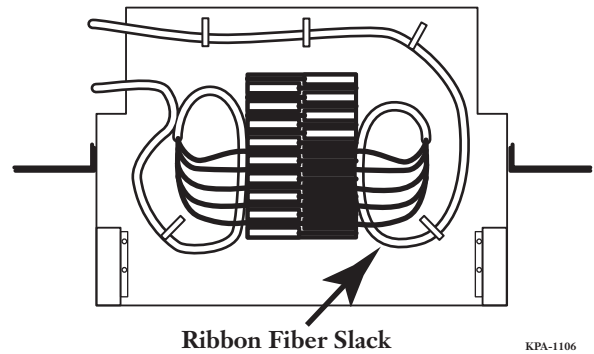

KPA-1106

Figure 14

Step 6: Record splice information appropriately on the record label on the inside of the front door of the housing.

IMPORTANT: Accurate recordkeeping is imperative to an organized installation.

Step 7: Replace the cover on the splice tray and secure it using the four screws.

Step 8: Reinstall the splice platform into the housing.

Step 9: Route ribbon fiber slack through the routing clips as shown (Figure 14).

5.4 Replace Doors (If They Were Removed)

Replace the front and rear doors if they were removed. Secure the doors using the quarter-turn fasteners.

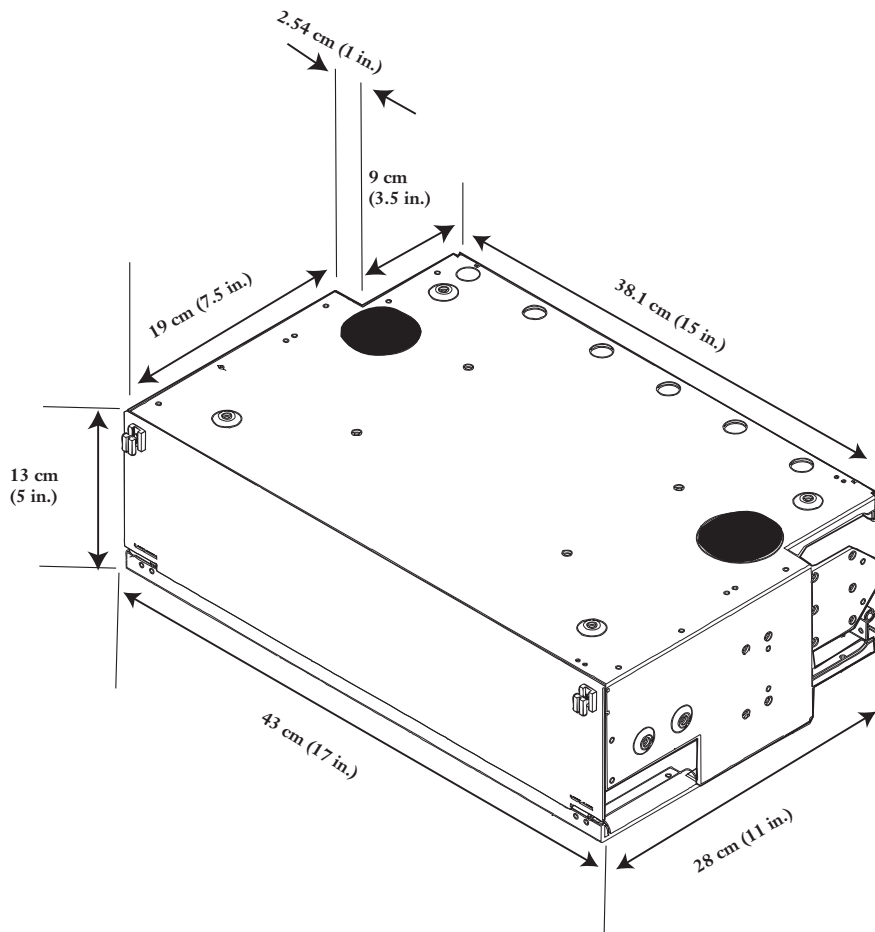

Figure 15

6. Maintenance

The unit requires very little maintenance to ensure fibers and parts remain in good condition.

- External components may be cleaned occasionally with a damp, nonabrasive cloth.
- Check nuts, bolts, and screws; tighten as needed.
- Check fiber optic cable to make sure bends do not exceed the minimum bend radius.
- Check cables for unnecessary strain, for crimping or crushing at entries and exits, and for damage.
- Check unit record labels to make sure all are clear and accurate.

**Corning Optical Communications LLC • PO Box 489 • Hickory, NC 28603-0489 USA
800-743-2675 • FAX: 828-325-5060 • International: +1-828-901-5000 • www.corning.com/opcomm**

Corning Optical Communications reserves the right to improve, enhance, and modify the features and specifications of Corning Optical Communications products without prior notification. A complete listing of the trademarks of Corning Optical Communications is available at www.corning.com/opcomm/trademarks. All other trademarks are the properties of their respective owners. Corning Optical Communications is ISO 9001 certified. © 2007, 2015 Corning Optical Communications. All rights reserved.
