

Document AN015  
 Issue 02  
 Description How to use relay function for MU-2-R module.  
 Author John Bell Application Engineer

To setup the MU-2 relay function, the modules are mounted onto the test boards and connected to the PC via USB or RS232 as shown below.



MU-2-R on MU2-USB

OR



MU-2-R on MU2-RS2 board

- To create a relay arrangement, follow procedure below. You will require a PC at the source station and at the target station.

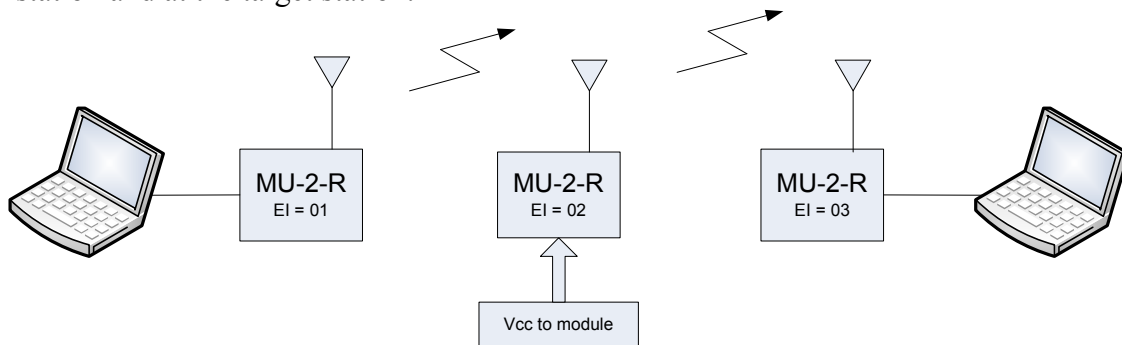

The relay module will require only Vcc and GND to function. You can:

- Use a spare RS232 board with module and connect Vcc by using a 9V battery using supplied 9V clip.
- You can solder directly to the module pins and attach 3-5V supply / do not go over 5V or damage to the module will occur.

- The MU-2-R modules must be setup with the following IDs:

Source	Relay	Target
UI = 0000	UI = 0000	UI = 0000
GI = 00	GI = 00	GI = 00
CH = 01	CH = 01	CH = 01
EI = 01	EI = 02	EI = 03

*Make sure that you enter "@EIxx/W" so the module remembers the setting when power is removed. See p32 of MU-2-R operation guide.*  
*Tip: program the relay module first in any board and then remove the relay module.*

These methods allow you to program the settings inside the modules:

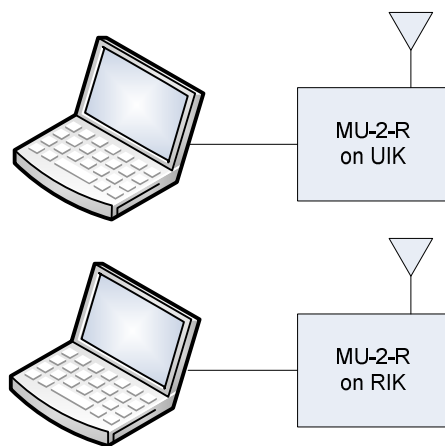

3. Command window:

When you open Evaluation Software, enter commands by reviewing chapter 5.4.1.2 “Data transmit command 2” of the MU-2 Operation Guide. Check the values match in the above table. Set the following command at source: **@DT04TEST/R02,03**

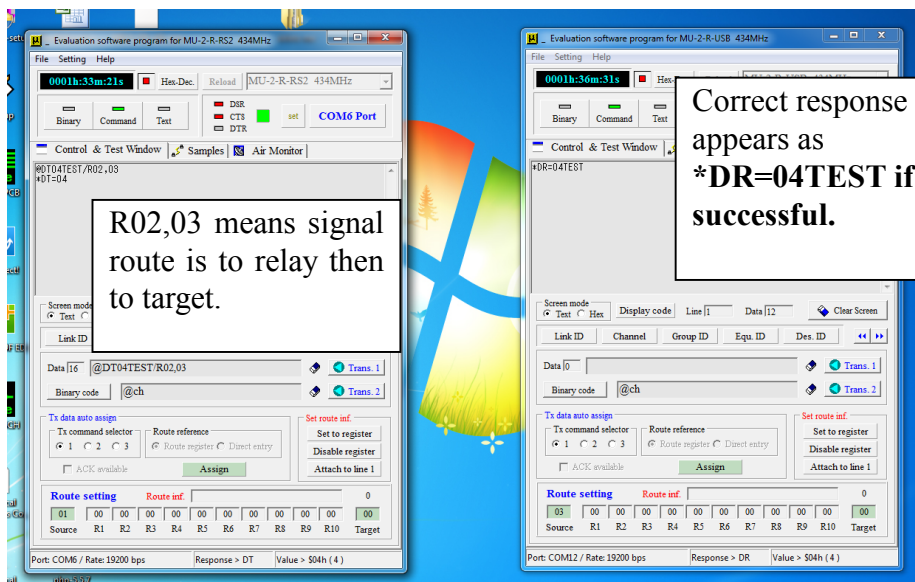

As the message is transmitted, relay board TX/RX LED both flash briefly.

You can also enter route information in the Route Setting area below. Click in one of the boxes (R1-R10, Target) and input using the virtual keypad. Once selection has been made, the corresponding box will highlight blue.

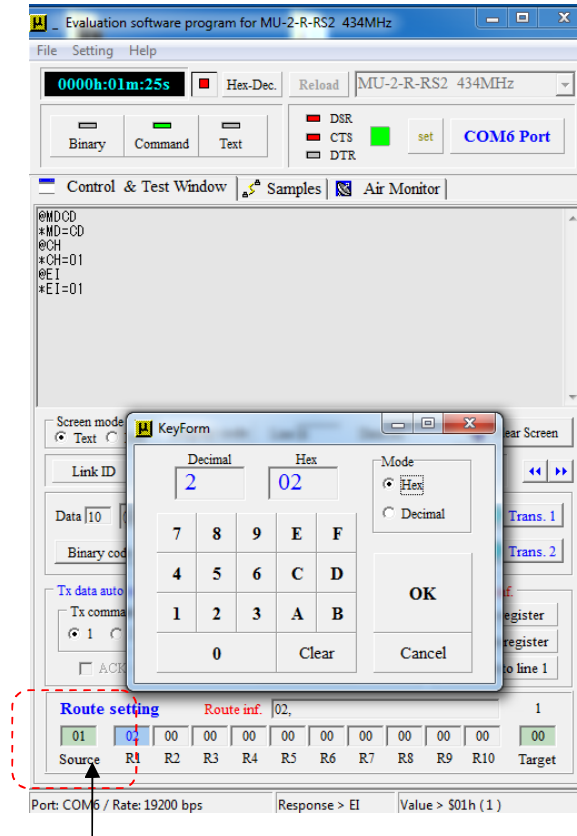

**\*Using the packet function\***

The *packet function* is a special command that allows a signal to travel through relay and to a target, and then instruct the target to transmit the signal back through the relay and to source. The evaluation window for the source will acknowledge this transmission. Both the relay and target can be made portable with just power supply (3-5V). The setup is as follows:

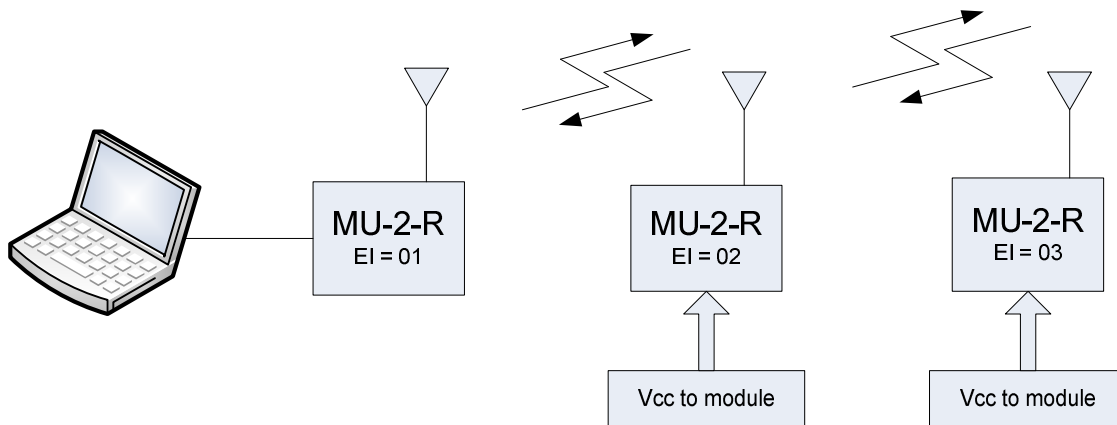

Open evaluation software and set the **Source EI = 01, Relay EI = 02, Target = 03**. Enter command “@CP03ABC/02,03” in the source window. Data is looped back to the source. No data appears in RX window. In TX window: \*DR=03ABC

## Revision History

Issue	Date	Comment
01	2014/01/22	Start of document
02	2014/04/22	Photographs updated

---

**Circuit Design, Inc. all rights reserved.**

**No part of this document may be copied or distributed in part or in whole without the prior written consent of Circuit Design, Inc.**

---