

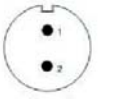





**SPECIFICATIONS**

Back Shell:	V-0 Fire Resistance
Insert Material:	Temperature Range 260°C
Contact Material:	Brass
Contact Plating:	Gold over Nickel
Contact Termination:	Solder
Cable OD Range:	Type A 4-7mm
	Type B 7-12mm
IP Rating:	IP68
Mating Cycle:	500 Times minimum
Temperature Range:	-40°C to +85°C
Humidity:	+40°C to 95°C±3%
Vibration:	10-500Hz 100m/S
Shock:	40-80/min 250m/S

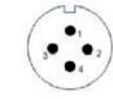
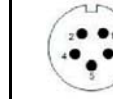
Series	Type	Male/Female
CWP	SP-21XX	X
Circular Water-proof Connector	XX= See Dwg.	P=Male Plug S=Female Socket PC=Plug w/ Cover SC=Socket w/ Cover

Positions	Cable Diam.
XX	X
02-12 See Chart	(SP-2110, SP-2111) A=4-7mm B=7-12mm

Configuration	Insert Configuration, Female Face View						
							
	2pole	3pole	4pole	5pole	7pole	9pole	12pole
Part # (CWP-SP-21XX-X-XX)	02	03	04	05	07	09	12
Current Rating	30A	30A	30A	15A	15A	5A	5A
Size & No. Contacts	Ø3X2	Ø3X3	Ø3X4	Ø2X5	Ø2X7	Ø1X9	Ø1X12
Rated Voltage	500V	500V	500V	500V	500V	500V	400V
Test Voltage	1500V	1500V	1500V	1500V	1500V	1500V	1200V
Contact Resistance mΩ	1	1	1	2.5	2.5	5	5
Insulation Resistance mΩ	2000	2000	2000	2000	2000	2000	2000
Wire Size mm <sup>2</sup> /AWG	≤4.17/11	≤4.17/11	≤4.17/11	≤2/14	≤2/14	≤0.785/18	≤0.785/18









RoHS compliant

Rev.	Description	Date	Approved	Drawing	Name	Date
				Approved	Howard	02/02/10
				Checked	Lizzy	02/02/10
				Drawn	Tina	02/02/10
				0.0 ± 0.35	0.00 ± 0.20	Angles ± 3'
					UNIT: mm	

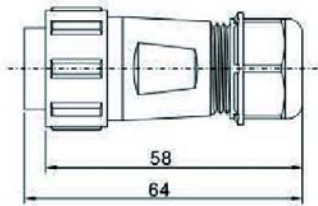
**Central Components Manufacturing**  
 440 Lincoln Blvd., Middlesex, New Jersey 08846  
 Phone 732 469-5720 888 288-5152 Fax 732 469-1919

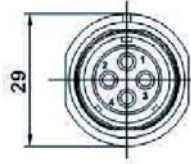
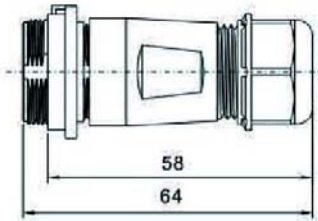
Part No.: **CWP-SP-21XX-X-XX-X**

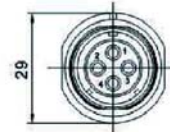
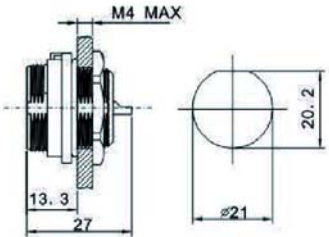
Description: Circular Waterproof Connector

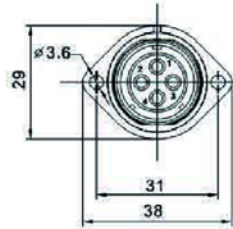
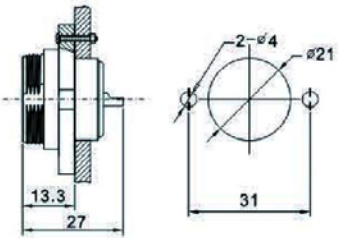
	1	2	3	4	5	6	7	8	9
A			This item mates with CWP-SP-2111, CWP-SP-2112, CWP-SP-2113 Threaded coupling Solder Termination.						
B	CWP-SP-2110-P	CWP-SP-2110-S							
B			This item mates with CWP-SP-2110 Threaded coupling Solder termination						
C	CWP-SP-2111-P	CWP-SP-2111-S							
C			This item mates with CWP-SP-2110, "D" hole with a nut on the back Solder termination						
D	CWP-SP-2112-P	CWP-SP-2112-S							
D			This item mates with CWP-SP-2110, Install by screws Solder termination						
E	CWP-SP-2113-P	CWP-SP-2113-S							
E									
F									
F									
G									
G									

Rev.	Description	Date	Approved	Drawing	Name	Date
				Approved	Howard	02/02/10
				Checked	Lizzy	02/02/10
				Drawn	Tina	02/02/10
				0.0 ± 0.35	0.00 ± 0.20	Angles ± 3'
					UNIT: mm	

**Central Components Manufacturing**  
 440 Lincoln Blvd., Middlesex, New Jersey 08846  
 Phone 732 469-5720 888 288-5152 Fax 732 469-1919

Part No.: **CWP-SP-21XX-X-XX-X**

Description: Circular Waterproof Connector