

CET-TP25D SERIES

High Frequency 150 Watts
Planar Transformers

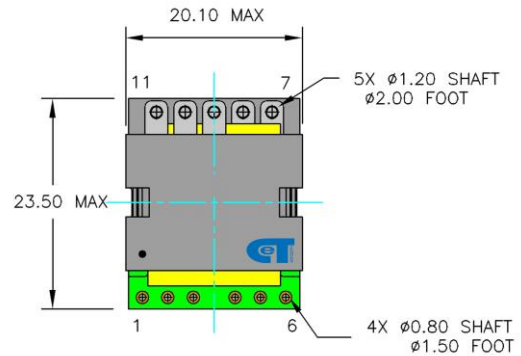

FEATURES

- Power Rating Up to 150 Watts
- High Efficiency of over 98%
- High Power Density of 600 Watts Per Cubic Inch
- Footprint 23.5 mm X 20.10 mm
- Lower Profile of 9.12 mm
- High Isolation (operational) 1500 Vdc
- High Frequency 200 kHz – 700 kHz
- Operating Temperature -40° C to +125° C

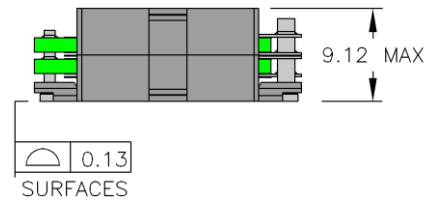

DESCRIPTION

The TP25 series of planar transformers are optimized for power supplies of high performance DC/DC converters. Due to an optimized core, winding geometry and interleaving technology, they are able to offer a high efficiencies up to over 98 percent, high power density of 600 watts per cubic inch, but lower profile of 9.12 mm. The series are consisted of 15 part numbers, off-the-shelf catalog parts can be arranged to 130 different winding configurations. Adding a primary auxiliary winding or a small gap to transformers, they will be have more expanding of configurations. The series are intended for use of DC/DC converter supply with forward, full-bridge, half-bridge ar and push – pull power supplies. Topologies in application with input voltages between 18 and 75 volts, and output voltages from 52 volts down to 1.xx volts.

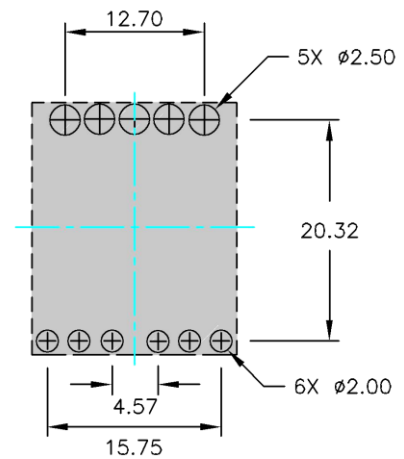

SUGGESTED PAD LAY-OUT

Weight.....11.60 grams
Tray.....40/tray

CET-TP25 SERIES

High Frequency 150 Watts
Planar Transformers

ELECTRICAL SPECIFICATIONS											
Part Number	Primary ¹ Inductance (uH min.)	Leakage ² Inductance (uH max.)	DC Resistance (m Ω Max)			Secondary	Turns Ratio		primary Second Hi Pot	Figure	M. Height
			Primary				Primary (A/B)	Secondary			
			A	B	AUX						
TP25D0802	151.0	0.43	18.0	18.0	N/A	0.85&0.85	4T/4T	1T & 1T	1500 Vdc	A	9.12 mm Max
TP25D0902	191.0	0.43	18.0	20.0	N/A		4T/5T				
TP25D1002	236.0	0.48	20.0	20.0	N/A		5T/5T				
TP25D1102	286.0	0.55	20.0	25.0	N/A		5T/6T				
TP25D1202	340.0	0.60	25.0	25.0	N/A		6T/6T				
TP25D0803	151.0	0.43	18.0	18.0	N/A	1.70 & 1.70	4T/4T	2T & 1T	1500 Vdc	B	9.12 mm Max
TP25D0903	191.0	0.43	18.0	20.0	N/A		4T/5T				
TP25D1003	236.0	0.48	20.0	20.0	N/A		5T/5T				
TP25D1103	286.0	0.55	20.0	25.0	N/A		5T/6T				
TP25D1203	340.0	0.60	25.0	25.0	N/A		6T/6T				
TP25D0804	151.0	0.43	18.0	18.0	N/A	7.00	4T/4T	4T (1T:1T:1T:1T)	1500 Vdc	C	9.12 mm Max
TP25D0904	191.0	0.43	18.0	20.0	N/A		4T/5T				
TP25D1004	236.0	0.48	20.0	20.0	N/A		5T/5T				
TP25D1104	286.0	0.55	20.0	25.0	N/A		5T/6T				
TP25D1204	340.0	0.60	25.0	25.0	N/A		6T/6T				

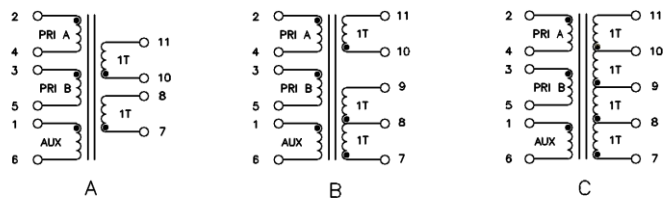

SCHEMATICS

NOTES:

1. The inductance is measured with both primary windings connected in series Pin (2--5) with Pin (3--4) shorted.
2. The leakage inductance is measured in winding Pin (2 -4) with all other winding shorted.
3. All specifications typical at T_A=25° C.