

CT500-2 operation

The CT500-2 is fully automatic once installed properly. The LED indicator lights inform the user of the progress of the charging cycle and confirm proper connections.

CT500-2 LED indicators

The dual color charging mode light indicates the state of charge of the battery. The light will illuminate only when the charger is properly connected to the battery and AC power is applied. Red indicates bulk charging, flashing red/green indicates absorption or topping off, while green indicates the battery is fully charged.

Please review the table below for electrical specifications.

PARAMETER	DESCRIPTION / CONDITIONS	MIN	NOM	MAX	UNITS
V_{FSTERM}	Fast charge voltage, 25C	28.8	29.0	29.1	VDC
V_{FLOAT}	Float voltage, $I_{OUT} < 1.0$ A, 25 C	26.8	27.0	27.2	VDC
I_{FS}	Fast charge, $V_{BATTERY} = 12V$	2.5	2.6	2.8	Amps
I_{FLTERM}	Float charge termination current	0.8	1.0	1.2	Amps
V_{AC}	RMS AC voltage range	90	120	132	VAC
I_{SBY}	Standby current, AC off			0.5	ma

The CT500-2 must be connected to the battery in order for the LEDs to illuminate. Should no illumination appear, unplug the unit and recheck battery connections to ensure proper polarity. The red wire connects to the positive and the black to the negative battery terminal.

If the charger is left for extended periods of time, it is advisable to check to be certain that the green light is on and the battery voltage is less than 27.2VDC.

Over temperature: The CT500-2 will reduce its charging current as its case temperature increases to insure proper operation. In the event of a charger over temperature, the unit will turn off until it cools and then restart automatically.

Over voltage protection (OVP): If the red light marked "Service" ever illuminates, the unit should be removed and returned to the factory. This light indicates that the internal over-voltage protection shut off has been tripped and the unit will shut down.

LIMITED WARRANTY

For two years from date of purchase, Chargetek Inc. will at its discretion repair or replace for the original consumer, free of charge, any part or parts found to be defective by Chargetek in workmanship or material. All shipping charges under this warranty must be paid by the consumer. Proof of purchase is required.

There is no other expressed warranty. Implied warranties, including those of merchantability and fitness for a particular purpose are limited to two years from the date of purchase. This is the exclusive remedy and consequential damages are excluded where permitted by law.



CT500-2

Installation Manual

Outline and mounting

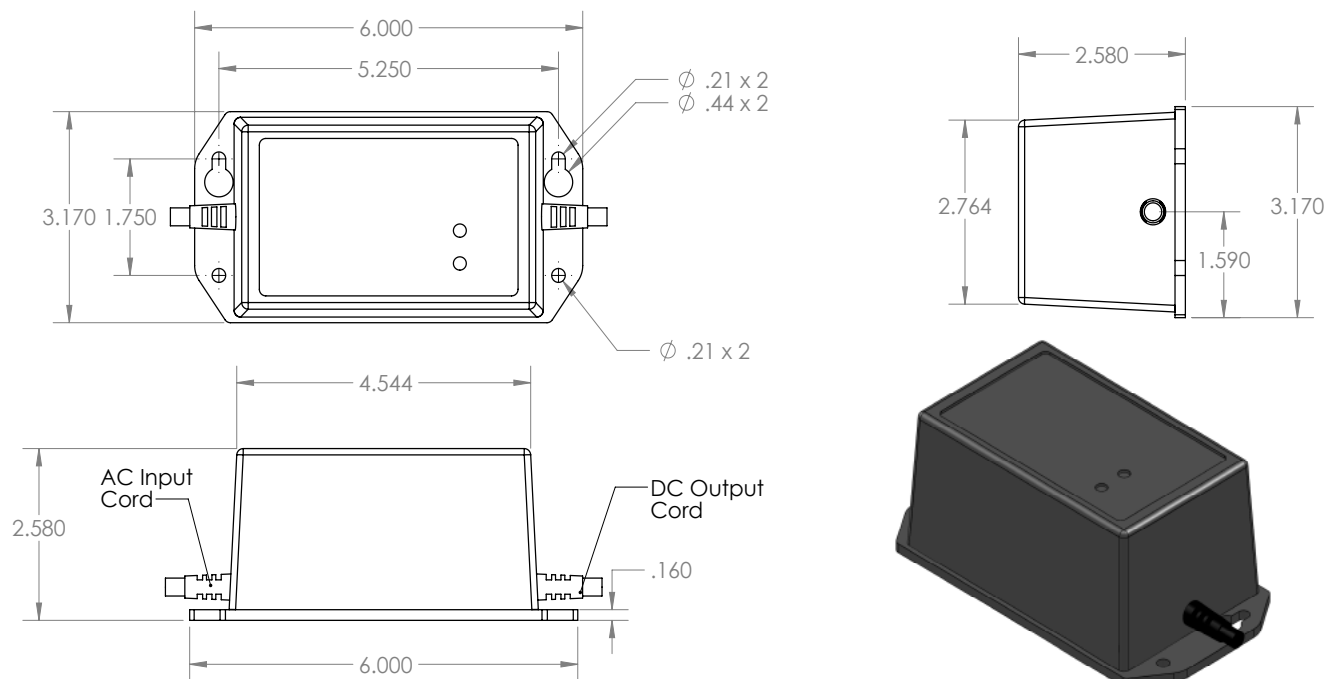

Dimensions in inches

5/12/14 Ver. A

Please read the entire installation manual before installing the battery charger. If there are any questions or concerns, please email us or call our toll-free number given below.

The CT500-2 UL/CSA 1236 certified battery charger is totally waterproof and precisely regulated. It is designed to be portable or permanently mounted on almost any type of vehicle including generators, ATVs, RVs, lawn and garden tractors, snowmobiles, motorcycles, and personal watercraft. This

product line is particularly suited for storage, security, standby and remote applications. The charger can be left connected to the battery indefinitely.

The CT500-2 is a three stage charger that ensures that the battery is recharged with precision and will be restored to its full capacity as fast as possible while prolonging its life. The charger is rugged, reliable and completely automatic.

CHARGETEK

409 Calle San Pablo, Unit 104, Camarillo, CA 93012 ~ Phone: (866) 482-7930 ~ Fax: (805) 482-7936

WWW.CHARGETEK.COM

Installation

Location

- ❑ Do not mount directly over or under a battery or onto a carpeted, upholstered or varnished surface.
- ❑ Install in an area where all charger electrical cords will avoid hot surfaces such as exhaust pipes and moving parts such as fan wheels.
- ❑ Operating temperature is -10°C to 55°C (-14°F to 131°F). Storage temperature is -30°C to 80°C (-22°F to 176°F).
- ❑ Provide as much surrounding cooling clearance as possible for maximum efficiency, safety, and shortest recharge times. At a minimum, maintain a 3 inch clearance around the perimeter and the top side of the charger.
- ❑ Never mount in the vicinity of explosives, pressurized cans or other flammable material.

Mounting

- ❑ Wear safety goggles, gloves and a long sleeve shirt when drilling mounting holes near a battery.
- ❑ In most cases, #10 stainless steel mounting bolts with aircraft nuts, nylocks, or #10 screws will provide for solid mounting.
- ❑ For extreme vibration conditions common in ATV and PWC applications, added security such as crossed shock cords are recommended.

Electrical

AC wire connections

- ❑ The CT500-2 is equipped with a factory installed 6 foot AC cord with a ground connection. The ground connection is the round pin on the AC plug. **It is extremely important that only grounded electrical outlets or extension cords with a ground connection should be used when operating this charger.**
- ❑ Never connect the AC plug into an electrical outlet if you are wet or barefoot.
- ❑ Ensure that the AC cord cannot reach moving parts, lids, hoods, etc. Secure with a cable tie to solid anchor point if necessary.
- ❑ The charger will operate properly with either 120 volts 50 Hz or 120 volts 60 Hz AC input. Never use 220 volts AC with this unit.

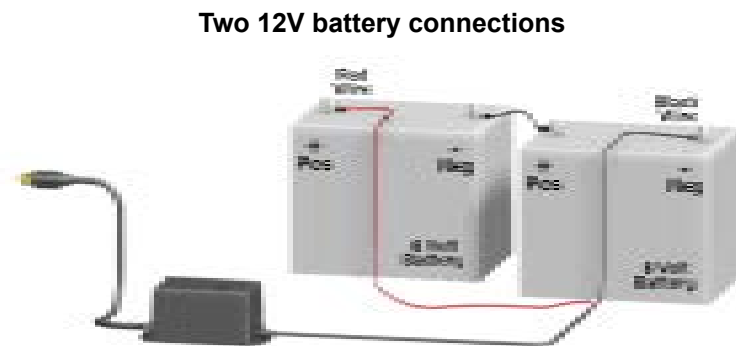

DC wire connections

- ❑ DC wire connections to the battery should be made before plugging in the AC cord.
- ❑ The charger should only be used with lead-acid type batteries such as AGM, SLA, flooded or maintenance free. If there is any question, please contact the factory.
- ❑ The charger will not operate until DC connections are made.
- ❑ When installing in the bilge of boats or any battery compartment, ensure that hatches are open and bilge blowers are operating for ten minutes to remove any fumes and hydrogen gas. Be certain the area is ventilated for personal health and safety.
- ❑ Keep wire routing from the charger to the battery neat and secure by anchoring with cable tie to a solid surface every few inches, not to exceed 18 inch intervals.
- ❑ Ensure that cables have sufficient clearance from moving parts and hot surfaces such as exhaust components.
- ❑ The CT500-2 is short circuit protected. Batteries are a high current source and additional protection is needed in the event of physical damage to the DC cables or the charger, or electrical damage that may be externally induced. An in-line fuse (32 volts/5 amps rating) connected between the positive battery charger lead and the battery positive terminal is required for maximum safety. The fuse's mechanical attributes are installation and environmentally specific. Consult the factory if selection assistance is required.
- ❑ For a single 24 volt battery, connect the charger DC cable to the battery as follows: the red lead is connected to the positive terminal of the battery and the black lead is connected to the negative terminal of the battery. When charging two 6 volt batteries connected in a series, connect the red lead of the charger to the positive terminal of battery #1. Connect the negative terminal of battery #1 to the positive terminal of battery #2. Connect the black lead of the charger to the negative terminal of battery #2. All connections should be clean and tight. See installation diagram below.
- ❑ When connecting two batteries in series, it is imperative that the amount of charge and discharge be equal for both batteries. If there is an imbalance during charge or discharge, excessive battery voltage will occur. This results in an over-voltaged battery and will cause dangerous battery out gassing and destruction. For accurate charge balancing, use the dual output chargers such as the CT500-1 or TPRO series.

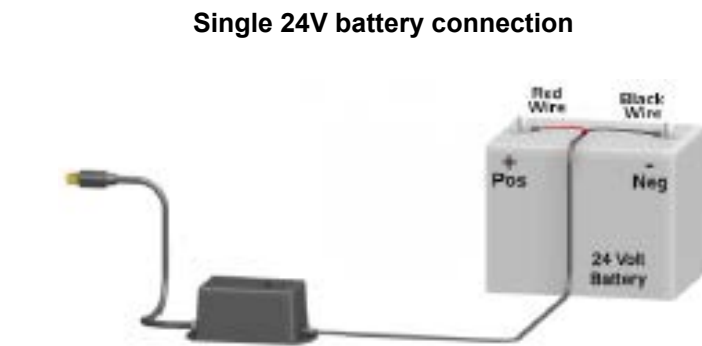

Safety instructions

CAUTION: The following are important safety instructions. Save these instructions.

- ❑ Charge only lead acid, maintenance free, refillable, or "gel-cell" rechargeable batteries. Other types of batteries may burst causing personal injury or damage.
- ❑ Never smoke or allow sparks or flame in the vicinity of a battery.
- ❑ Someone should be within the range of your voice and close enough to come to your aid when you are working near a battery.
- ❑ Wear eye protection and clothing protection. Avoid touching your eyes while working near a battery.
- ❑ Have plenty of fresh water and soap nearby in case the battery acid contacts your skin, clothing or eyes.
- ❑ If the battery acid contacts skin or clothing, wash immediately with soap and water. If acid enters your eyes, immediately flood them with cold running water for at least ten minutes and get immediate medical attention.
- ❑ Never operate a charger with a damaged cord or plug. Degradation of AC and DC cords, accidentally nicking or cutting the cords could result in sparking and cause injury.
- ❑ Never operate a charger that has been damaged in any way or try to disassemble it. Return it to the factory when service or replacement is required. Incorrect reassembly may result in an electrical shock or fire.
- ❑ Become familiar with all instructions and cautionary markings on chargers, batteries and equipment used. Only adults should install and operate the charger. The charger and batteries should be kept out of the reach of children.
- ❑ When using an extension cord, the CT500-2 requires a quality grounded extension cord of at least 18 awg wire size for cords up to 50 feet and a minimum of 16 awg for cords up to 150 feet.
- ❑ Never unplug a cord by pulling on the cord itself. Always grasp the plug when disconnecting the charger.
- ❑ The CT500-2 is waterproof and designed for harsh environments. It is not designed to be submerged. Please consult the factory if there are any questions.
- ❑ Never charge a frozen battery. If the battery has an odor or is visibly damaged, disconnect the charger and consult the factory.
- ❑ Study the battery manufacturer's precautions such as removing or not removing cell caps while charging.
- ❑ Keep batteries full. Add distilled water in each cell until it reaches the levels specified by the battery. Check the battery fluid levels regularly.
- ❑ Good battery maintenance procedures dictate that the battery fluid levels be checked on a regular basis, especially in high ambient temperatures.
- ❑ Keep the battery terminals clean. Always unplug the charger before cleaning. Keep corrosion from coming into contact with your eyes.
- ❑ Remove personal metal items such as rings, bracelets, necklaces, and watches when working with a lead-acid battery. A lead-acid battery can produce a short circuit high enough to weld objects to metal, causing a severe burn.

Three stage charge cycle

The CT500-2 employs a three stage charge routine. This is the charging procedure most lead-acid battery manufacturers recommend to return full capacity efficiently and extend battery life.

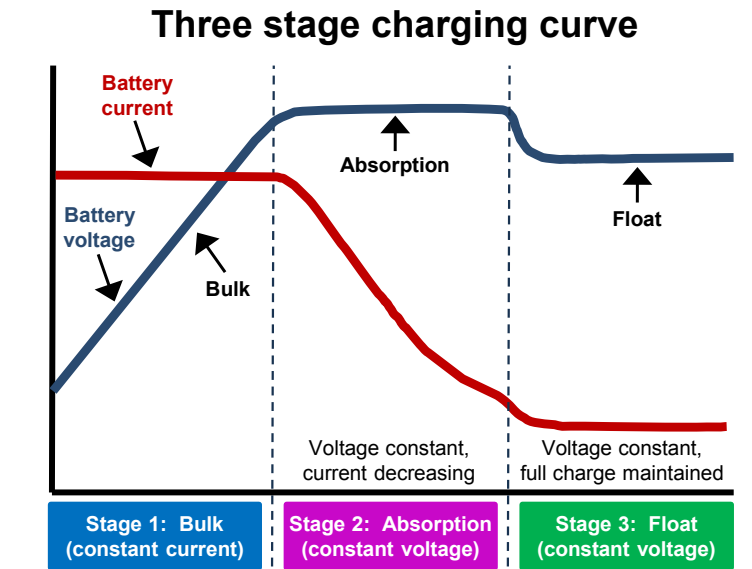

Stage 1: Constant current or bulk charge mode

Assuming that the battery is starting in a discharged state, the charger is operating in constant current mode. The charger current is maintained at a constant value and the battery voltage is allowed to rise as it is being recharged. Approximately 80% of battery capacity is returned in the constant current region.

Stage 2: Absorption mode

When the battery voltage reaches approximately 2.4 volts per cell, or 28.8 volts for a 24V battery, the charger voltage is held constant at this level and the battery current is allowed to reduce. This voltage is maintained until the charging current reduces substantially indicating a full charge. At this point, the battery is fully charged.

Stage 3: Float mode

Float mode is the final stage of the charging routine. During float mode, the voltage on the battery is maintained at approximately 2.25 volts per cell, or 27 volts for a 24V battery. This voltage will maintain the full charge condition of the battery without boiling out electrolyte or overcharging the battery.