

MESSRS : \_\_\_\_\_

AGENT : \_\_\_\_\_

**SPECIFICATION  
OF  
THERMOPILE  
INFARAED SENSOR**

MODEL NO. : TS-S3NAB

PART NO. : \_\_\_\_\_

176-17 Hirooka, Tottori-shi, 689-1193 JAPAN  
TEL : +81-857-53-4666 FAX : +81-857-53-3532

APPROVED BY	CHECKED BY	DRAWN BY

MODEL NO. : TS-S3NAB	DRAWING NO. : 1106152	REV : A	PAGE 1 / 8	JUNE ,11, 2015
PART NO. :				 <b>NIPPON CERAMIC CO., LTD.</b>

SCOPE

THIS SPECIFICATION DESCRIBES A THERMOPILE INFRARED SENSOR SUPPLIED BY NIPPON CERAMIC CO., LTD.

TYPE OF SENSOR

SINGLE ELEMENT TYPE.

PHYSICAL CONFIGURATION

- 1) PACKAGE : TO-5 METAL CAN WITH DIMENSIONS SHOWN IN FIGURE 1-C
- 2) ELEMENT GEOMETRY : SENSITIVE AREA 2.56 mm<sup>2</sup>
- 3) ELEMENT ORIENTATION : SEE FIGURE 1-B
- 4) LEAD CONFIGURATION : SEE FIGURE 1-C, 1-D

ELECTRICAL CHARACTERISTICS (AT 25±5 °C)

- 1) CIRCUIT CONFIGURATION : FOUR-TERMINAL SENSOR  
SEE FIGURE 2
- 2) SIGNAL OUTPUT : 11.9 mV<sub>0-p</sub>  
(REFERENCE)  
(CONDITIONS) ENERGY : 43.54 mW/cm<sup>2</sup> (323K AT SHUTTER OPENING)  
AMP. GAIN : WITHOUT AMP.  
TEST SET-UP BLOCK DAGRAM : REFER TO FIGURE 2
- 3) RESISTANCE OF THERMOPILE (Pin1~Pin2)  
: 526kΩ ± 100kΩ (at 25°C)
- 4) REFERENCE RESISTOR (Pin3~Pin4)  
: 100kΩ ± 10% (at 25°C)

OPTICAL CHARACTERISTICS

- 1) FIELD OF VIEW : 111° FROM CENTER OF SENSITIVE ELEMENT  
: SEE FIGURE 1-A
- 2) RENS SUBSTRATE : SILICON
- 3) CUT ON (5% TABS) : 5.0 ± 0.5 μm
- 4) TRANSMISSION : ≥70% AVERAGE 7.0~14 μm (SEE FIGURE 4)

MODEL NO. : TS-S3NAB	DRAWING NO. :	REV :	PAGE	JUNE ,11, 2015
PART NO. :	1106152	A	2 / 8	 NIPPON CERAMIC CO., LTD.

ENVIRONMENTAL REQUIREMENTS

- 1) OPERATING TEMPERATURE : -30°C TO +80°C
- 2) STORAGE TEMPERATURE : -30°C TO +100°C
- 3) RELATIVE HUMIDITY :

THE SENSOR SHALL OPERATE WITHOUT INCREASE IN NOISE OUTPUT WHEN EXPOSED TO 90 ~ 95 % RH AT 30 °C CONTINUOUSLY.

MODEL NO. : TS-S3NAB	DRAWING NO. :	REV :	PAGE	JUNE ,11, 2015
PART NO. :	1106152	A	3 / 8	 NIPPON CERAMIC CO., LTD.

**CONFIGURATION (FIGURE 1)**

**【FIELD OF VIEW】**  
(FIGURE 1-A)

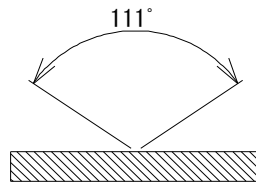

**【TOP VIEW】**  
(FIGURE 1-B)

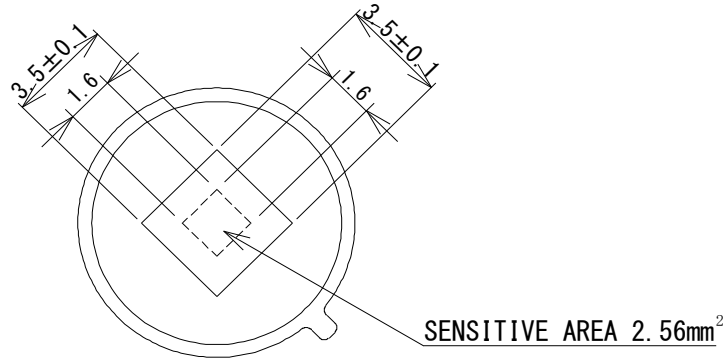

**【SIDE VIEW】**  
(FIGURE 1-C)

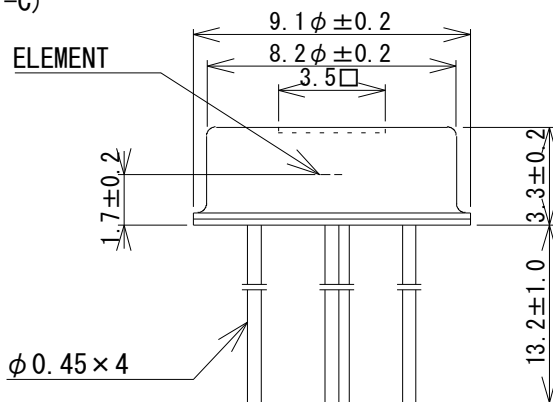

**【BOTTOM VIEW】**  
(FIGURE 1-D)

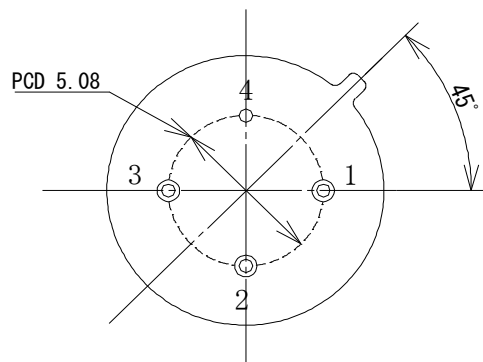

- 1. THERMOPILE (-)
- 2. THERMOPILE (+)
- 3. THERMISTOR
- 4. GROUND

UNIT : mm

MODEL NO. : TS-S3NAB	DRAWING NO. : 1106152	REV : A	PAGE 4 / 8	JUNE ,11, 2015
PART NO. :				NIPPON CERAMIC CO., LTD.

CIRCUIT CONFIGURATION(Figure 2)

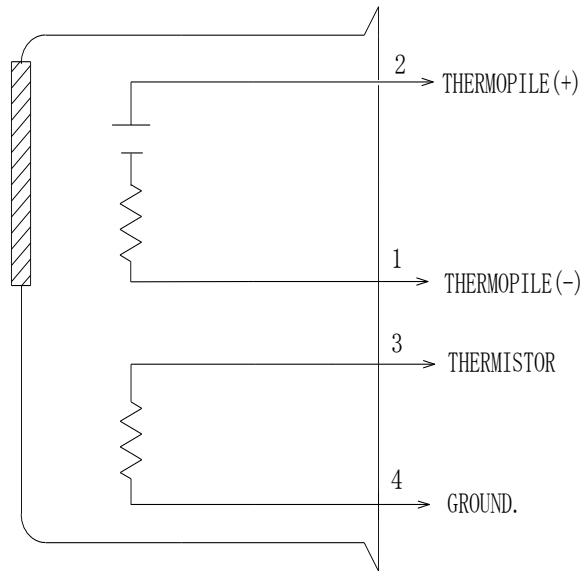

TEST SET-UP (BLACKBODY) COMPOSITION (Figure 3)

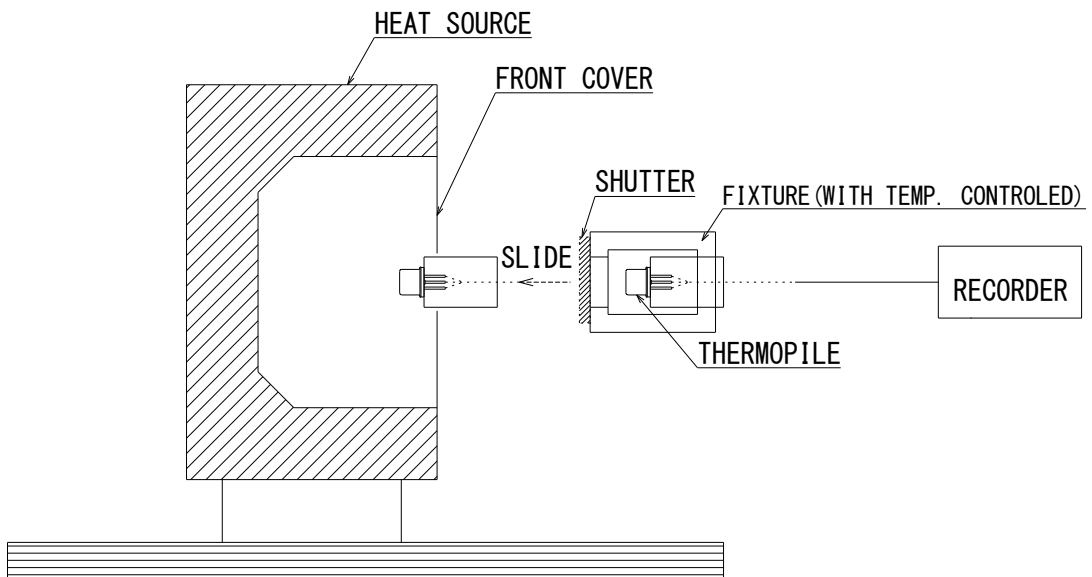

- ※ BLACK BODY (FLAT) : 323K (50°C)
- AMP. : WITHOUT AMP.
- DISTANCE : 50 mm
- TEMP. INSIDE FRONT COVER : 298K (25°C)

MODEL NO. : TS-S3NAB	DRAWING NO. : 1106152	REV : A	PAGE 5 / 8	JUNE ,11, 2015
PART NO. :				NIPPON CERAMIC CO., LTD.

TRANSMISSION (FIGURE 4)

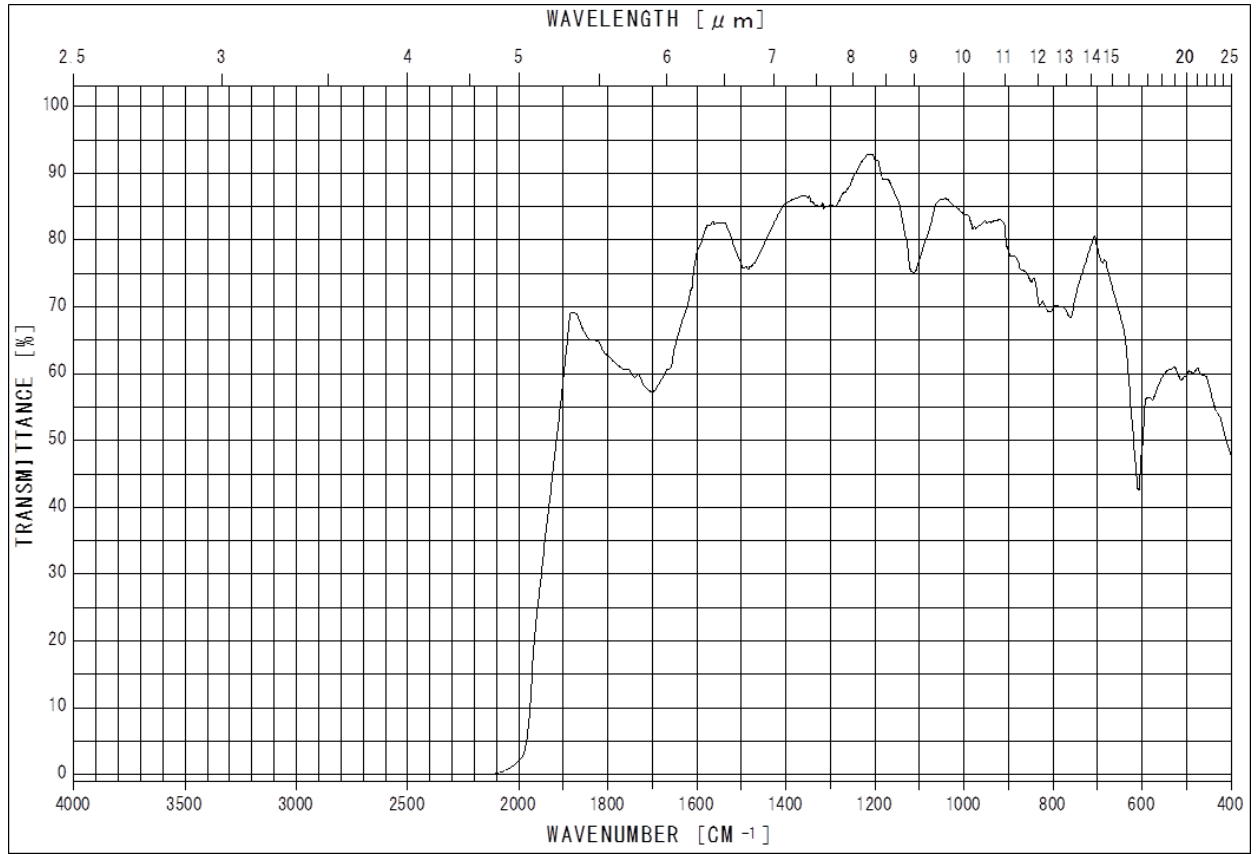

MODEL NO. : TS-S3NAB	DRAWING NO. : 1106152	REV : A	PAGE 6 / 8	JUNE ,11, 2015
PART NO. :				 NIPPON CERAMIC CO., LTD.

※ NOTES

1. DESIGN RESTRICTIONS/PRECAUTIONS

IF USED FOR OUTDOOR APPLICATIONS, BE SURE TO APPLY SUITABLE SUPPLEMENTARY OPTICAL FILTER AND DRIP-PROOF, ANTI-DEW CONSTRUCTION. THIS SENSOR IS DESIGNED FOR INDOOR USE. IN CASES WHERE SECONDARY ACCIDENTS DUE TO OPERATION FAILURE OR MALFUNCTIONS CAN BE ANTICIPATED, ADD A FAIL SAFE FUNCTION TO THE DESIGN.

2. USAGE RESTRICTIONS/PRECAUTIONS

TO PREVENT SENSOR MALFUNCTIONS, OPERATIONAL FAILURE OR ANY DETERIORATION OF ITS CHARACTERISTICS, DO NOT USE THIS SENSOR IN THE FOLLOWING, OR SIMILAR, CONDITIONS.

- A. IN RAPID ENVIRONMENTAL TEMPERATURE CHANGES.
- B. IN STRONG SHOCK OR VIBRATION.
- C. IN A PLACE WHERE THERE ARE OBSTRUCTING MATERIALS (GLASS, FOG, ETC.) THROUGH WHICH INFRARED RAYS CANNOT PASS WITHIN DETECTION AREA.
- D. IN FLUID, CORROSIVE GASES AND SEA BREEZE.
- E. CONTINUAL USE IN HIGH HUMIDITY ATMOSPHERE.
- F. IN FIELD OF STATIC ELECTRICITY OR STRONG ELECTROMAGNETIC WAVES.
- G. EXPOSED TO DIRECT WIND FROM A HEATER OR AIR CONDITIONER.

3. ASSEMBLY RESTRICTIONS/PRECAUTIONS

SOLDERING -----

- A. USE SOLDERING IRONS WHEN SOLDERING.
- B. AVOID KEEPING PINS OF THIS SENSOR HOT FOR A LONG TIME AS EXCESSIVE HEAT MAY CAUSE DETERIORATION OF ITS QUALITY. (E. G. WITHIN 10 SEC. AT 260°C)

WASHING -----

- A. BE SURE TO WASH OUT ALL FLUX AFTER SOLDERING AS REMAINDER MAY CAUSE MALFUNCTIONS.
- B. USE A BRUSH WHEN WASHING. WASHING WITH AN ULTRASONIC CLEANER MAY CAUSE OPERATIONAL FAILURE.

4. HANDLING AND STORAGE RESTRICTIONS/PRECAUTIONS

TO PREVENT SENSOR MALFUNCTIONS, OPERATIONAL FAILURE, APPEARANCE DAMAGE OR ANY DETERIORATION OF ITS CHARACTERISTICS, DO NOT EXPOSE THIS SENSOR TO THE FOLLOWING OR SIMILAR, HANDLING AND STORAGE CONDITIONS.

- A. VIBRATION FOR A LONG TIME.
- B. STRONG SHOCK.
- C. STATIC ELECTRICITY OR STRONG ELECTROMAGNETIC WAVES.
- D. HIGH & LOW TEMPERATURE AND HUMIDITY FOR A LONG TIME.
- E. CORROSIVE GASES OR SEA BREEZE.
- F. DIRTY AND DUSTY ENVIRONMENTS THAT MAY CONTAMINATE THE OPTICAL WINDOW.

MODEL NO. : TS-S3NAB	DRAWING NO. :	REV :	PAGE	JUNE ,11, 2015
PART NO. :	1106152	A	7 / 8	 NIPPON CERAMIC CO., LTD.

5. RESTRICTIONS ON PRODUCT USE

THE PRODUCT DESCRIBED IN THIS DOCUMENT SHALL NOT BE USED OR EMBEDDED TO ANY DOWNSTREAM PRODUCTS OF WHICH MANUFACTURE. USE AND/OR SALES ARE PROHIBITED UNDER ANY APPLICABLE LAWS AND REGULATIONS.

SENSOR TROUBLES RESULTING FROM MISUSE, INAPPROPRIATE HANDLING OR STORAGE ARE NOT THE MANUFACTURER' S RESPONSIBILITY.

MODEL NO. : TS-S3NAB	DRAWING NO. :	REV :	PAGE	JUNE ,11, 2015
PART NO. :	1106152	A	8 / 8	 NIPPON CERAMIC CO., LTD.