



CCTC
三环集团

潮州三环（集团）股份有限公司
Chaozhou Three-Circle (Group) Co., Ltd.

地址：广东省潮州市凤塘三环工业城

邮编(Post Code)：515646

ADD：San Huan Industrial District ,Feng Tang Chao Zhou,GuangDong,China

承 认 书

SPECIFICATION FOR APPROVAL

客户名称：
CUSTOMER: _____

产品名称： 多层片式瓷介电容器
PARTNAME: Multilayer Chip Ceramic Capacitor

产品规格： M3L 系列

SPECIFICATION: _____

承认书编号
APPROVAL SHEET NO.: DRAAW108F/0-2014

发出日期
ISSUED DATE: _____

制造 MANUFACTURER			客户 CUSTOMER		
批准 APPROVED	审核 CHECKED	经办 PREPARED	批准 APPROVED	审核 CHECKED	经办 PREPARED
李艳红	王彬彬	洛国佳			

潮州三环（集团）股份有限公司

地址：中国广东省潮州市凤塘三环工业城

电话：86-768-6855932

传真：86-768-6855921

网址：HTTP: //WWW.CCTC.CC



CCTC
三环集团

潮州三环（集团）股份有限公司
Chaozhou Three-Circle (Group) Co., Ltd.

地址：广东省潮州市凤塘三环工业城 邮编(Post Code)：515646

ADD: San Huan Industrial District ,Feng Tang Chao Zhou, GuangDong, China

文件编号	DRAAW108F/0-2014		页数	26
文件名称	多层片式陶瓷电容器(产品承认书)		制订日期	2012.01
版数	制定、修订日期	页数	制定、修订内容	登记者
E/0	2012-2-29	25	制定节能灯专用产品承认书	张国信
F/0	2014-05-05	26	换版	张国信



CCTC
三环集团

潮州三环（集团）股份有限公司
Chaozhou Three-Circle (Group) Co., Ltd.

地址：广东省潮州市凤塘三环工业城 邮编(Post Code)：515646
ADD：San Huan Industrial District ,Feng Tang Chao Zhou,GuangDong,China

产品标准书	编号 Document No.
SPECIFICATION FOR APPROVAL	DRAAW108F/0-2014

目录

1. 电容器及介质分类.....	3
2. 产品命名.....	4
3. 产品用途.....	5
4. 产品容量范围	6
5. 产品尺寸.....	7
6. 技术要求和测试条件.....	8
7. 产品包装.....	16
8. MLCC 使用注意事项	21



CCTC
三环集团

潮州三环（集团）股份有限公司
Chaozhou Three-Circle (Group) Co., Ltd.

地址：广东省潮州市凤塘三环工业城

邮编(Post Code)：515646

ADD：San Huan Industrial District ,Feng Tang Chao Zhou,GuangDong,China

产品标准书	编号 Document No.
SPECIFICATION FOR APPROVAL	DRAAW108F/0-2014

1. 电容器及介质分类 Types of Capacitor and Dielectric Material

※M3L：此类介质材料的电容器为 I 类电容器，此类产品电性能较稳定，几乎不随电压和时间变化，容量随温度变化率为 0.1%，适用于损耗低、要求较高的电路中。

※M3L : The capacitor of this kind dielectric material is considered as Class I capacitor. The electrical properties of M3L capacitor are stably and have little change with voltage and time. The coefficient of temperature is 0.1%/°C, They are suited for applications where low-losses and high-stability are required.



产品标准书 SPECIFICATION FOR APPROVAL	编号 Document No.
	DRAAW108F/0-2014

2. 产品命名 Product Parts Numbering System

(例) (example)

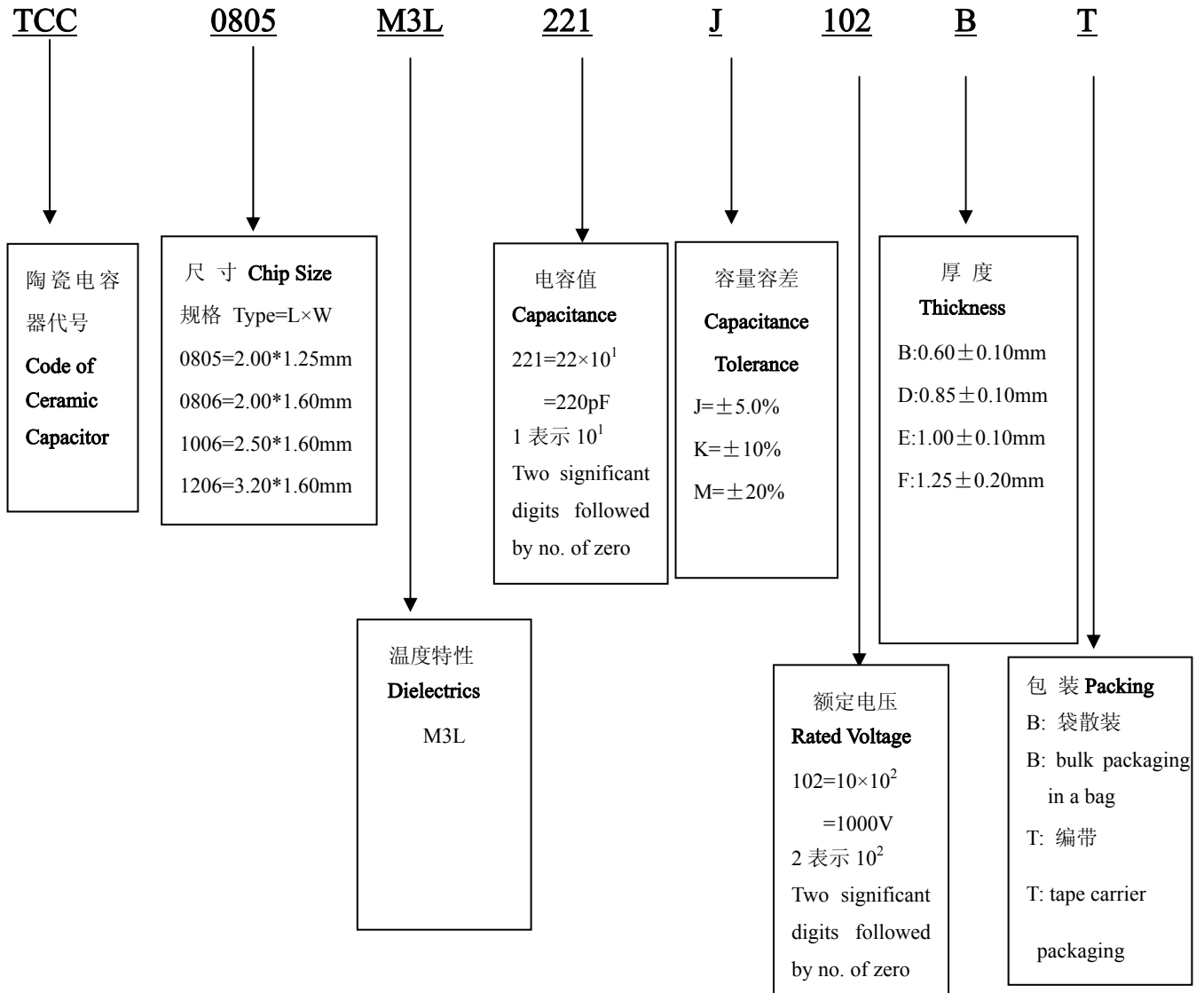



产品标准书 SPECIFICATION FOR APPROVAL	编号 Document No.
	DRAAW108F/0-2014

3. 产品用途

节能灯常用电路图

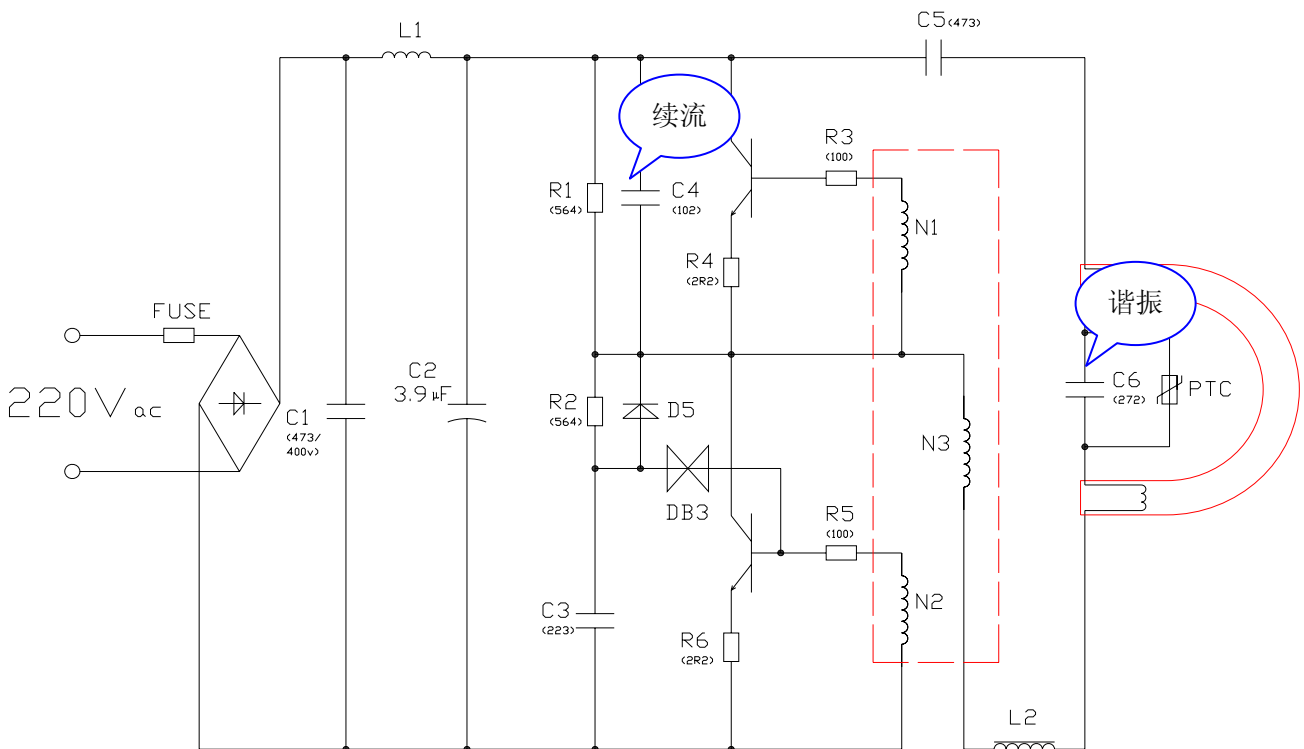

各位置应用电容：

C4 位置：续流电容

C6 位置：谐振电容



产品标准书 SPECIFICATION FOR APPROVAL	编号 Document No.
	DRAAW108F/0-2014

4. 产品容量范围 Product Capacitance Range

4.1 续流电容

尺寸	材质	M3L
	容量	1000V
0805	221	B
	331	B
	471	B
	561	B
	681	B
	821	D
	102	D
0806	152	D
1006	182	D
	222	D
1206	222	D
	272	D

4.2 谐振电容

尺寸	材质	M3L
	容量	1200V
1006	152	D
	182	D
	222	D
1206	152	D
	182	D
	222	D
	272	D
	332	D
	392	D
	472	E

*以上容量规格仅供参考，具体可根据客户要求制作



产品标准书 SPECIFICATION FOR APPROVAL	编号 Document No.
	DRAAW108F/0-2014

5. 产品尺寸 Dimensions

规格：0805、0806、1006、1206。

Chip Size：0805、0806、1006、1206。

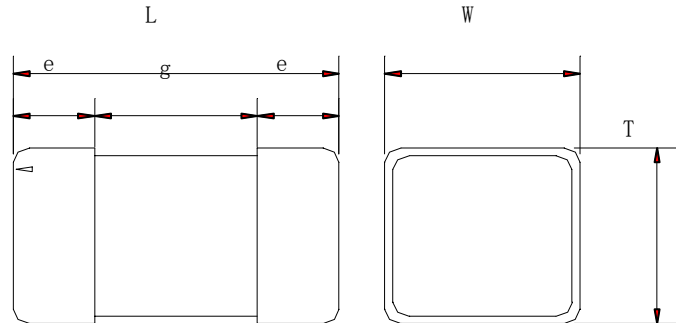

规格 Type	L (mm)	W (mm)	e (mm)	g min (mm)	T (mm)				
0805	2.00±0.10	1.25±0.10	0.2~0.7	0.7	0.60±0.10	0.85±0.10	—	—	—
0806	2.00±0.10	1.60±0.10	0.2~0.7	0.7	—	0.85±0.10	—	—	—
1006	2.50±0.10	1.60±0.10	0.3~0.8	0.9	—	0.85±0.10	1.25±0.20	—	—
1206	3.20±0.10	1.60±0.10	0.3~0.8	1.6	—	0.85±0.10	1.00±0.10	1.25±0.20	1.60±0.20



产品标准书 SPECIFICATION FOR APPROVAL	编号 Document No.
	DRAAW108F/0-2014

6. 技术要求和测试条件 Specification and Test Condition

6.1 外观 Appearance

类型 Dielectrics	技术要求 Specification	测试条件 Testing Condition
M3L	无损伤或异常 No defects or abnormalities	目视检查 Visual inspection.

6.2 尺寸 Dimensions

类型 Dielectrics	技术要求 Specification	测试条件 Testing Condition
M3L	在要求的范围内 Within the specified dimensions	用千分尺 Using calipers on micrometer

6.3 容量 Capacitance

类型 Dielectrics	技术要求 Specification	测试条件 Testing Condition
M3L	在要求的容值容差范围内 Within the specified tolerance J: ±5%; K: ±10%; M: ±20%	1.0±0.2Vrms, 1KHz±10% 20~30℃, 环境湿度≤70%预处理后 48hrs。 at 20~30℃, humidity under 70%, 48hrs after annealing

6.4 损耗 Dissipation Factor

类型 Dielectrics	技术要求 Specification	测试条件 Testing Condition
M3L	DF≤2.5%	1.0±0.2Vrms, 1KHz±10% (Cp>10uF, 0.5±0.2Vrms, 120Hz) 20~30℃, 环境湿度≤70%预处理后 48hrs。



产品标准书	编号 Document No.
SPECIFICATION FOR APPROVAL	DRAAW108F/0-2014

6.5 绝缘电阻 Insulation Resistance

类型 Dielectrics	技术要求 Specification	测试条件 Testing Condition												
M3L	COG/M3L 大于 10 GΩ 或 100Ω·F(大于其中较小的数值) X7R 大于 4G 或 100Ω·F(大于其中较小的数值) COG/M3L More than 10 GΩ or 100Ω·F, whichever is smaller. X7R More than 4 GΩ or 100Ω·F, whichever is smaller.	20~30℃,环境湿度小于 70%,测量时间 60±5 秒, 测量电压如下: <table border="1" style="margin-left: 20px;"> <tr> <td style="text-align: center;">额定电压</td> <td style="text-align: center;">≤400V</td> <td style="text-align: center;">>400V</td> </tr> <tr> <td style="text-align: center;">测量电压</td> <td style="text-align: center;">U_R</td> <td style="text-align: center;">400V</td> </tr> </table> Test for 60±5sec, at 20 ~ 30 °C , humidity under 70% , under test voltage: <table border="1" style="margin-left: 20px;"> <tr> <td style="text-align: center;">U_R</td> <td style="text-align: center;">≤400V</td> <td style="text-align: center;">>400V</td> </tr> <tr> <td style="text-align: center;">U_T</td> <td style="text-align: center;">U_R</td> <td style="text-align: center;">400V</td> </tr> </table>	额定电压	≤400V	>400V	测量电压	U _R	400V	U _R	≤400V	>400V	U _T	U _R	400V
额定电压	≤400V	>400V												
测量电压	U _R	400V												
U _R	≤400V	>400V												
U _T	U _R	400V												

6.6 耐电压 Dielectric Strength

类型 Dielectrics	额定电压范围 Rated voltage range	耐电压性能测试方法 Measuring Method												
M3L	无损坏或异常 No defects or abnormalities.	当在电容器的两端施加试验电压 5 秒钟, 充电电流不超过 50 mA <table style="margin-left: 20px;"> <tr> <td style="text-align: center;">额定电压</td> <td style="text-align: center;">测试电压</td> </tr> <tr> <td style="text-align: center;">50V</td> <td style="text-align: center;">125V</td> </tr> <tr> <td style="text-align: center;">100V</td> <td style="text-align: center;">400V</td> </tr> <tr> <td style="text-align: center;">400V</td> <td style="text-align: center;">750V</td> </tr> <tr> <td style="text-align: center;">1000V</td> <td style="text-align: center;">1400V</td> </tr> <tr> <td style="text-align: center;">1200V</td> <td style="text-align: center;">1500V</td> </tr> </table> Failure shall be observed the testing voltage is applied between the terminations for 5 seconds, provided the charge /discharge current is less than 50mA	额定电压	测试电压	50V	125V	100V	400V	400V	750V	1000V	1400V	1200V	1500V
额定电压	测试电压													
50V	125V													
100V	400V													
400V	750V													
1000V	1400V													
1200V	1500V													



产品标准书 SPECIFICATION FOR APPROVAL	编号 Document No.
	DRAAW108F/0-2014

6.7 静电容量温度特性 Temperature Coefficient of Capacitance

类型 Dielectrics	技术要求 Specification	测试条件 Testing Condition														
M3L	容量变化在-0.05%/°C ~ -0.15%/°C以内 Temperature coefficient within -0.05%/°C ~ -0.15%/°C	<p>按系列温度顺序测试电容容量 Measure capacitance under follow table list temperature:</p> <table border="1"> <tr> <th colspan="2">步骤</th> </tr> <tr> <th colspan="2">STEP</th> </tr> <tr> <td>1</td> <td>25 ±2</td> </tr> <tr> <td>2</td> <td>-55±3</td> </tr> <tr> <td>3</td> <td>25 ±2</td> </tr> <tr> <td>4</td> <td>15 ±3</td> </tr> <tr> <td>5</td> <td>25 ±2</td> </tr> </table> <p>1) M3L 容量漂移的计算方法为：用步骤 3 测量的电容容量除以在第 1、3 和 5 步骤测量得到的误差的最大值和最小值的差。 温度系数的计算以第 3 步骤测量电容容量为参考 The capacitance drift is calculated by dividing the differences between the maximum and minimum measured values in the step 1,3 and 5.</p>	步骤		STEP		1	25 ±2	2	-55±3	3	25 ±2	4	15 ±3	5	25 ±2
步骤																
STEP																
1	25 ±2															
2	-55±3															
3	25 ±2															
4	15 ±3															
5	25 ±2															



产品标准书 SPECIFICATION FOR APPROVAL	编号 Document No.
	DRAAW108F/0-2014

6.8 附着力 Adhesion

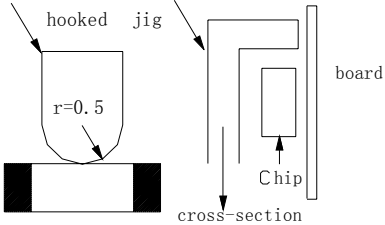
类型 Dielectrics	技术要求 Specification	测试条件 Testing Condition
M3L	端电极无松动, 也无其它不良现象 No removal of the terminations or other defect shall occur.	施加 6N(=600g*f)的压力, 并保持 10±1 秒 The pressurizing force shall be 6N (=600g*f) and the duration of application shall be 10±1sec. 

6.9 可焊性 Solderability of Termination

类型 Dielectrics	技术要求 Specification	测试条件 Testing Condition
M3L	端电极挂锡面积不小于 95%, 针孔或粗糙面积小于 5% 95% min. coverage of both terminal electrodes and less than 5% have pin holes or rough spots.	锡炉温度: 245±5℃ 浸入时间: 2±1 秒 两侧端电极完全浸入焊锡炉 Solder temperature: 245±5℃ Dipping time: 2±1 seconds. Completely soak both terminal electrodes in solder

6.10 耐焊性 Resistance to leaching

类型 Dielectrics	技术要求 Specification	测试条件 Testing Condition
M3L	端电极挂锡面积不小于 95%, 针孔或粗糙面积小于 5%, 外观无开裂 95% min. coverage of both terminal electrodes and less than 5% have pin holes or rough spots. No remarkable visual damage.	预热: 120℃~150℃/60 秒 锡炉温度: 270±5℃ 浸入时间: 10±1 秒 两侧端电极完全浸入焊锡炉 Solder temperature: 270±5℃ preheated: 120℃~150℃/60sec Dipping time: 10±1 seconds. Completely soak both terminal electrodes in solder



产品标准书 SPECIFICATION FOR APPROVAL	编号 Document No.
	DRAAW108F/0-2014

6.11 端电极结合强度 Bending

类型 Dielectrics	技术要求 Specification	测试条件 Testing Condition
M3L	无可见损伤; 容量变化小于等于±5% 或 0.5 PF No remarkable visual damage Cp change ≤ ±5% or ≤ 0.5 pF	<p>将片状电容器安装在测试夹具上，按图所示方向以 1.0mm/s 的速率施加压力，弯曲 1mm。</p> <p>Solder the capacitor on testing substrate and put it on testing stand. The middle part of substrate shall successively be pressurized by pressuring rod at a rated of about 1.0mm/sec. Until the deflection become means of the 1.0mm.</p>



产品标准书	编号 Document No.
SPECIFICATION FOR APPROVAL	DRAAW108F/0-2014

6.12 耐焊接热 Resistance to Soldering Heat

类型 Dielectrics	技术要求 Specification	测试条件 Testing Condition
M3L	无明显可见损伤 容量变化： $-2.5\% \leq \Delta C/C \leq +2.5\%$ 或 $-0.25\text{pF} \leq \Delta C/C \leq +0.25\text{pF}$ （取较大值）以内 DF 满足产品初始值的要求 IR 满足产品初始值的要求 No remarkable visual damage Cp change within $\pm 2.5\%$ or $\pm 0.25\text{pF}$, whichever is larger. DF meets initial standard value. IR meets initial standard value.	焊接温度: 270±5℃ 预热: 120~150℃ 60 秒 浸入时间: 10±1 秒 在室温下放置 24±2 (M3L)小时以后测量 试验后在标准条件下恢复 *高介电常数电容器的初始值测量 在 140~150℃ 进行 1 小时的热处理后在室温下放置 48±4 小时 测量初始值 Soldering temperature: 270±5℃ Preheating: 120~150℃ 60sec. Dipping time: 10±1 seconds. Measurement to be made after being kept at room temperature for 24±2 (M3L) hours. Recovery for the following period under the standard condition after test. *Initial measurement for high dielectric constant type Perform a heat treatment at 140~150℃ for 1hr and let sit for 48±4hrs at room temperature. Perform the initial measurement.



产品标准书	编号 Document No.
SPECIFICATION FOR APPROVAL	DRAAW108F/0-2014

6.13 温度快速循环 Temperature Cycle

类型 Dielectrics	技术要求 Specification	测试条件 Testing Condition															
M3L	无明显可见损伤 容量变化在 $-2.5\% \leq \Delta C/C \leq 2.5\%$ 或 $-0.25\text{pF} \leq \Delta C/C \leq 0.25\text{pF}$ ((取较大值) 以内 DF 满足产品初始值的要求 IR 满足产品初始值的要求 No remarkable visual damage Cp change within $\pm 2.5\%$ or $\pm 0.25\text{pF}$, whichever is larger. DF meets initial standard value. IR meets initial standard value	<p>按下列步骤进行 5 次循环： To perform 5 cycles of the stated environment</p> <table border="1" style="width: 100%; border-collapse: collapse;"> <thead> <tr> <th style="text-align: center;">步骤 Step</th> <th style="text-align: center;">温度 Temperature</th> <th style="text-align: center;">时间 Time</th> </tr> </thead> <tbody> <tr> <td style="text-align: center;">1</td> <td>下限类别温度 $+0/-3^{\circ}\text{C}$ Min. operating Temp. $+0/-3^{\circ}\text{C}$</td> <td style="text-align: center;">30min</td> </tr> <tr> <td style="text-align: center;">2</td> <td style="text-align: center;">25°C</td> <td style="text-align: center;">2~3 min</td> </tr> <tr> <td style="text-align: center;">3</td> <td>上限类别温度 $+3/-0^{\circ}\text{C}$ Max. operating Temp. $+3/-0^{\circ}\text{C}$</td> <td style="text-align: center;">30 min</td> </tr> <tr> <td style="text-align: center;">4</td> <td style="text-align: center;">25°C</td> <td style="text-align: center;">2~3 min</td> </tr> </tbody> </table> <p>在室温下放置 24 ± 2 (M3L) 小时以后测量 *高介电常数电容器的初始值测量 在 $140 \sim 150^{\circ}\text{C}$ 进行 1 小时的热处理后在室温下放置 48 ± 4 小时 测量初始值 Measurement to be made after being kept at room temperature for 24 ± 2 hrs (M3L) at room temperature, then measure. *Initial measurement for high dielectric constant type Perform a heat treatment at $140 \sim 150^{\circ}\text{C}$ for 1hr and let sit for 48 ± 4 hrs at room temperature. Perform the initial measurement.</p>	步骤 Step	温度 Temperature	时间 Time	1	下限类别温度 $+0/-3^{\circ}\text{C}$ Min. operating Temp. $+0/-3^{\circ}\text{C}$	30min	2	25°C	2~3 min	3	上限类别温度 $+3/-0^{\circ}\text{C}$ Max. operating Temp. $+3/-0^{\circ}\text{C}$	30 min	4	25°C	2~3 min
步骤 Step	温度 Temperature	时间 Time															
1	下限类别温度 $+0/-3^{\circ}\text{C}$ Min. operating Temp. $+0/-3^{\circ}\text{C}$	30min															
2	25°C	2~3 min															
3	上限类别温度 $+3/-0^{\circ}\text{C}$ Max. operating Temp. $+3/-0^{\circ}\text{C}$	30 min															
4	25°C	2~3 min															



产品标准书 SPECIFICATION FOR APPROVAL	编号 Document No. DRAAW108F/0-2014
-------------------------------------	-------------------------------------

6.14 稳态湿热 Moisture Resistance ,steady state

类型 Dielectrics	技术要求 Specification	测试条件 Testing Condition
M3L	外观无明显可见损伤 容量变化在±5%或 ±0.5pF（取较大值）以内 $C_p < 10\text{pF}$, $Q \geq 200 + 10C_p$; $10 \leq C_p < 30\text{pF}$, $Q \geq 275 + 2.5C_p$ $C_p \geq 30\text{pF}$, $Q \geq 350$ IR: 大于 1000MΩ 或 50Ω-F(取较小值) No remarkable visual damage Cp change within ±5% or ±0.5pF, whichever is larger. $C_p < 10\text{pF}$, $Q \geq 200 + 10C_p$; $10 \leq C_p < 30\text{pF}$, $Q \geq 275 + 2.5C_p$ $C_p \geq 30\text{pF}$, $Q \geq 350$ $R \cdot C \geq 1000\text{M}\Omega$ or 50Ω-F, whichever is smaller	测试温度: 40±2℃ 湿度: 90~95% RH 测试时间: 500 ±12hrs 在室温下放置 24±2 (M3L)小时以后测量 *高介电常数电容器的初始值测量 在 140~150℃进行 1 小时的热处理后 在室温下放置 48±4 小时 测量初始值 Test temperature: 40±2℃ Humidity: 90~95% RH Testing time: 500 ±12hrs Measurement to be made after being kept at room temperature for 24±2hrs (M3L) *Initial measurement for high dielectric constant type Perform a heat treatment at 140~150℃ for 1hr and let sit for 48±4hrs at room temperature. Perform the initial measurement.



产品标准书 SPECIFICATION FOR APPROVAL	编号 Document No.
	DRAAW108F/0-2014

7. 产品包装 Packing

7.1 袋式散装 Bulk Packing

10000 个/袋或按客户要求。Standard packing 10Kpcs/bag; others are according to customer request.

7.2 编带式包装 Tape Packing

纸带：4000 个/盘

Paper Tape: Standard taping (8mm paper width), 4Kpcs/reel

塑料带：适合 0805、0806、1006、1206 尺寸规格，厚度大于 0.95mm 的产品，2000 个/盘。

Plastic Tape: Suitable 0805、0806、1006 and 1206 sizes, for chip thickness over 0.95 mm 2Kpcs/reel are available.

7.2.1 纸带尺寸 Dimensions of Packing Paper

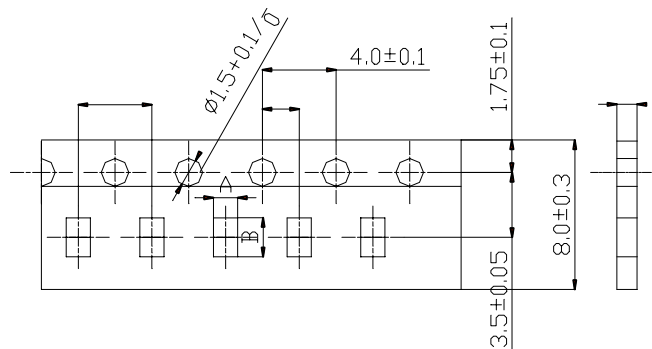

Type	A	B	C	D	T
0805	1.55 ± 0.15	2.3 ± 0.15	4.0 ± 0.10	2.0 ± 0.10	1.1max
0806	1.90 ± 0.15	2.25 ± 0.15	4.0 ± 0.10	2.0 ± 0.10	1.1max
1006	1.90 ± 0.15	2.8 ± 0.15	4.0 ± 0.10	2.0 ± 0.10	1.1max
1206	1.95 ± 0.15	3.5 ± 0.15	4.0 ± 0.10	2.0 ± 0.10	1.1max

(单位 unit: 毫米 mm)



产品标准书 SPECIFICATION FOR APPROVAL	编号 Document No.
	DRAAW108F/0-2014

7.2.2 塑料带尺寸 Dimensions of Embossed Packing

8mm宽，4mm间距编带

12mm宽，8mm/4mm间距编带

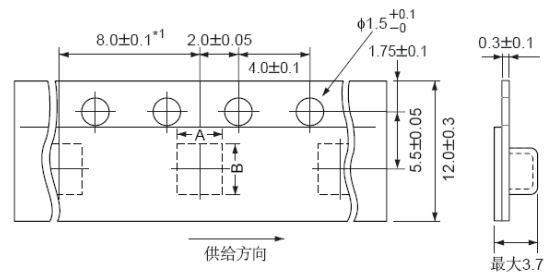
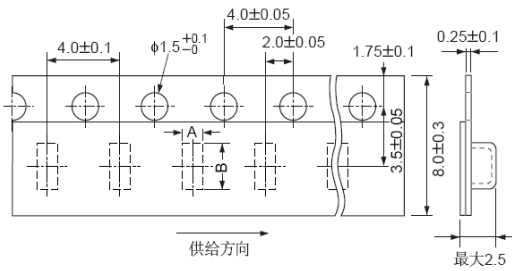

A: 1.45 ± 0.20 B: 2.25 ± 0.20 (0805)

A: 1.95 ± 0.20 B: 3.50 ± 0.20 (1206) (单位 unit:毫米 mm)

7.2.3 编带盘尺寸 Dimensions of Reel

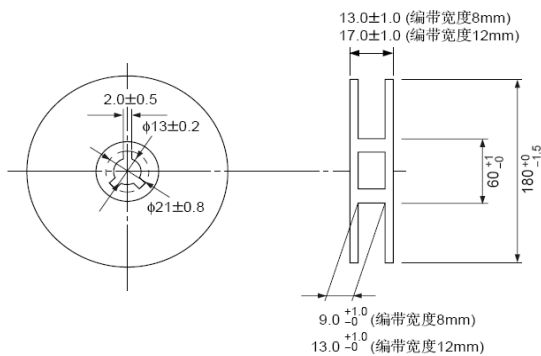

7.2.4 编带方式 Taping Figure

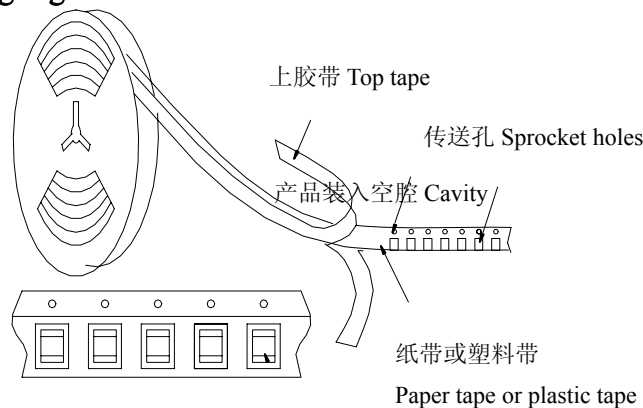



产品标准书 SPECIFICATION FOR APPROVAL	编号 Document No. DRAAW108F/0-2014
-------------------------------------	-------------------------------------

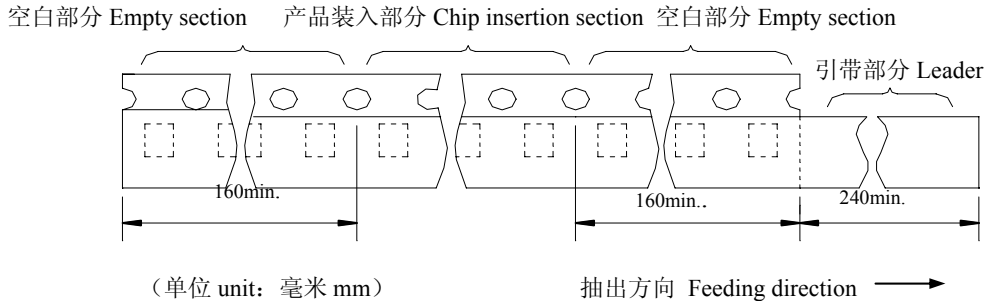

7.2.5 编带方法 Taping Method

- ① 包装电容器的编带是顺时针卷绕的，由上往下的方向拉出编带时，传送孔处于编带的右侧。
- ② 在编带的前端，至少留出 5 个间距的引出带。
- ③ 在编带时，必须按下图留出引出带部分或空白部分。
- ④ 在盘带的安装中的产品装错的数量每盘必须小于表示数量的 0.1% 或 1 个为限，不连续发生错误。
- ⑤ 上胶带和下胶带不应超出编带的边缘，不能挡住传送孔。
- ⑥ 传送孔的累计误差为 10 个间距：±0.3 毫米以内。
- ⑦ 上胶带的剥离力矩应在 0.1 至 0.6 牛顿以内，其方向如下图所示。

- ① Tapes for capacitors are wound clockwise. The sprocket holes are to the right as the tape is pulled toward the user.
- ② The top tape and base tape are not attached at the end of the tape for a minimum of 5 pitches.
- ③ Part of the leader and part of the empty tape shall be attached to the end of the tape as follows.
- ④ Missing capacitors number within 0.1% of the number per reel or 1pc, whichever is greater, and are not continuous.
- ⑤ The top tape and bottom tape shall not protrude beyond the edges of the tape and shall not cover sprocket holes.
- ⑥ Cumulative tolerance of sprocket holes, 10 pitches: ±0.3mm.
- ⑦ Peeling off force: 0.1 to 0.6N in the direction shown down.

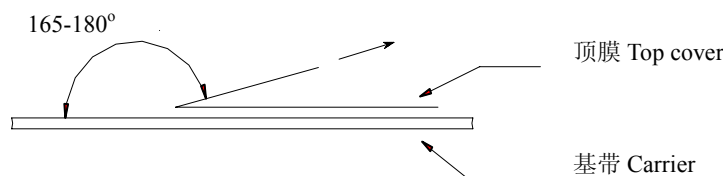



产品标准书 SPECIFICATION FOR APPROVAL	编号 Document No.
	DRAAW108F/0-2014

7.2.6 产品标签 Reel Label

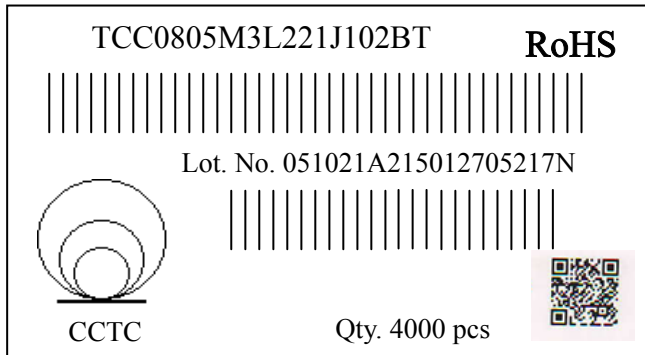

标签内容 The Contents of Label、

- (1) $\frac{TCC}{①}$ $\frac{0805}{②}$ $\frac{M3L}{③}$ $\frac{221}{④}$ $\frac{J}{⑤}$ $\frac{102}{⑥}$ $\frac{B}{⑦}$ $\frac{T}{⑧}$

①陶瓷电容器代号 Code of Ceramic Capacitor、②尺寸 chip size、

③温度特性 dielectrics、④容量 capacitance、⑤容量容差 tolerance、⑥额定电压 rated voltage、

⑦厚度 thickness、⑧ ⑧包装 packing

(2) 产品批号 Lot. No.: 051021A215012705217N

(3) 数量 Qty: 4000pcs

(4) RoHS:GREEN PARTS 绿色物料

7.2.7.外包装 Package

7.2.7.1 包装箱 Carton

7.2.7.1.1 包装箱尺寸 Carton Size

L	W	H
40cm	36cm	20cm

7.2.7.1.2 数量： 240Kpcs /箱 The Quantity: 240Kpcs /one carton

1 内包装盒=40,000PCS 1 INNER BOX=40,000PCS

1 包装箱 =40,000PCS × 6 包装盒=240,000PCS 1 CARTON=40,000PCS × 6BOX=240,000PCS

RoHS 标识(根据客户要求张贴) according to customer request



CCTC
三环集团

潮州三环（集团）股份有限公司
Chaozhou Three-Circle (Group) Co., Ltd.

地址：广东省潮州市凤塘三环工业城 邮编(Post Code)：515646
ADD：San Huan Industrial District ,Feng Tang Chao Zhou,GuangDong,China

产品标准书 SPECIFICATION FOR APPROVAL	编号 Document No.
	DRAAW108F/0-2014

7.2.7.2 内包装盒 Inner Box

7.2.7.2.1 包装盒尺寸 Size

L	W	H
18.5cm	6.5cm	19cm

7.2.7.2.2 数量：20Kpcs /盒

1 盘=4000PCS 1 REEL=4,000PCS

1 包装盒=4,000PCS × 10 盘 =40,000PCS 1 INNER BOX=4,000PCS × 10REEL =40,000PCS

7.2.7.2.3 内包装盒标签 The Label in Inner Box

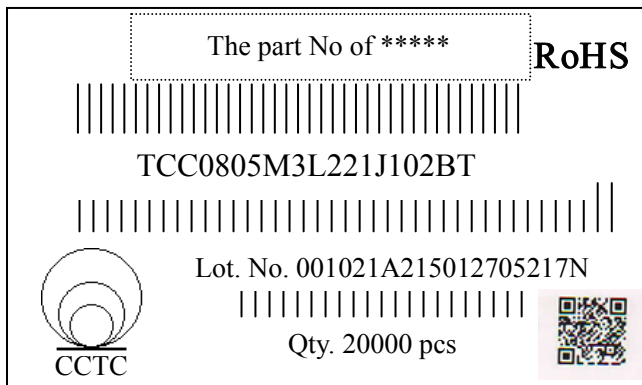



产品标准书	编号 Document No.
SPECIFICATION FOR APPROVAL	DRAAW108F/0-2014

8. MLCC 使用注意事项 Precautions on the use of MLCC

8.1 电路板设计 PCB Design

8.1.1 电路板图案设计 Design of Land-patterns

下面图和表格给出了部分推荐的设计图案，可以防止安装时焊锡量过多。

同时也给出了不正确的图案。

The following diagrams and tables show some examples recommended patterns to prevent excessive solder amounts (larger fillets which above the component end terminations)

Examples of improper pattern designs are also shown.

电路板设计推荐图案尺寸：

Recommended land dimensions for a typical chip capacitor land patterns for PCBs

波峰焊接时推荐设计的尺寸 (单位: mm):

Recommended land dimensions for wave-soldering (unit: mm)

规格 SIZE	0805	0806	1006	1206
尺寸	2.0	2.5	2.0	3.2
	1.25	1.6	1.6	1.6
A	1.0~1.4	1.0~1.4	1.3~1.9	1.8~2.5
B	0.8~1.5	0.8~1.5	0.8~1.6	0.8~1.7
C	0.9~1.2	1.2~1.6	1.2~1.6	1.2~1.6

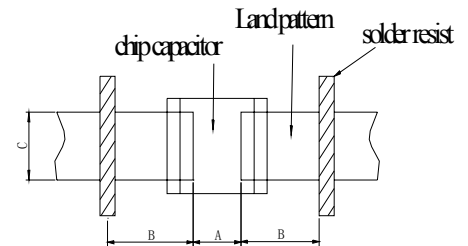

再流焊接时推荐设计的尺寸 (单位: mm)

Recommended land dimensions for reflow-soldering (unit: mm)

规格 SIZE	0805	0806	1006	1206
尺寸	L	2.0	2.0	2.5
	W	1.25	1.6	1.6
A	0.8~1.2	0.8~1.2	1.1~1.7	1.8~2.5
B	0.8~1.2	0.8~1.2	1.0~1.4	1.0~1.5
C	0.9~0.1.6	1.2~2.0	1.2~2.0	1.2~2.0

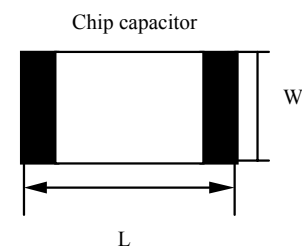

过量的焊锡会影响产品抵抗机械应力的能力，因此在设计图案时应引起注意。

Excess solder can affect the ability of chips to withstand mechanical stresses. Therefore, please take proper precautions when designing land-patterns.

在应用中一些焊接好与坏的情况：

Examples of good and bad solder application



产品标准书 SPECIFICATION FOR APPROVAL	编号 Document No.
	DRAAW108F/0-2014

项目 Item	不推荐结构 Not recommended	推荐结构 Recommended
片状元件和带引线的元件的混合焊接 Mixed mounting of SMD and leaded component		
靠近底座的焊接 Component placement close to the chassis		
在片状元件附近带引线元件的焊接 Hand-soldering of leaded components near mounted components		

8.1.2 图案结构

Pattern configurations

下面是电容器安装好与坏例子。选择贴装位置，应尽可能减小电路板在弯曲时受到的机械应力。

The following are examples of good and bad capacitor layout, SMD capacitors should be located to minimize any possible mechanical stresses from board warp or deflection..

	不推荐结构 Not recommended	推荐结构 Recommended
电路板弯曲 Deflection of the board		

对于电路板分拨的电容器，在分拨时受到的机械应力大小与电容器的安装有关。下面推荐了一些好的设计。

To layout the capacitors for the breakaway PC board, it should be noted that the amount of mechanical stresses given depending on capacitor layout. The example below shows recommendations for better design.



产品标准书 SPECIFICATION FOR APPROVAL	编号 Document No.
	DRAAW108F/0-2014

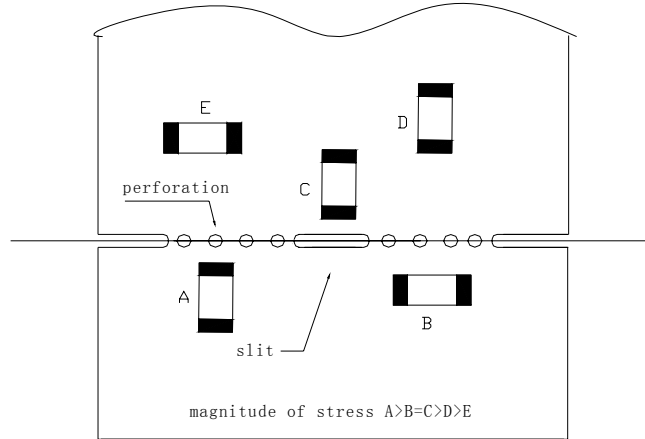

在沿着分拨线分拨电路板时，对产品施加的机械应力与使用的方法关系很大。分折电路板时片状元件受到的疲劳按照如下顺序增大：分折、剪切、V型槽、穿孔。因此，贴装时应该考虑电路板的分拨过程。

When breaking PC boards along their perforations, the amount of mechanical stress on the capacitors can vary according to the method used. The following methods are listed in order from least stressful to most stressful: push-back, slit, -grooving, and perforation. Thus, any ideal SMD capacitor layout must also consider the PCB splitting procedure.

8.2 自动贴装注意事项 Considerations for automatic placement

贴装机的调整 Adjustment of mounting machine

- ①. 产品在电路板贴装时，不应该受到过大的冲击。
- ②. 必须定期对吸头和定位爪进行检查、维修和更换
- ①. Excessive impact load should not be imposed on the capacitors when mounting the PC boards.
- ②. The maintenance and inspection of the mounters should be conducted periodically.

	不推荐结构 Not recommended	推荐结构 Recommended
单面贴装 Single-sided mounting		
双面贴装 Double-sided mounting		



产品标准书 SPECIFICATION FOR APPROVAL	编号 Document No.
	DRAAW108F/0-2014

8.3 推荐焊接曲线 Recommended soldering profile

8.3.1 说明：① 产品推荐使用回流焊接工艺；② 大尺寸产品适用于回流焊接工艺

8.3.1 Re: ①flow Soldering is recommended; ②flow soldering is suitable for bigger size MLCCs

8.3.2 锡铅焊接曲线 Recommended Sn&Pb soldering profile

再流焊 Reflow soldering

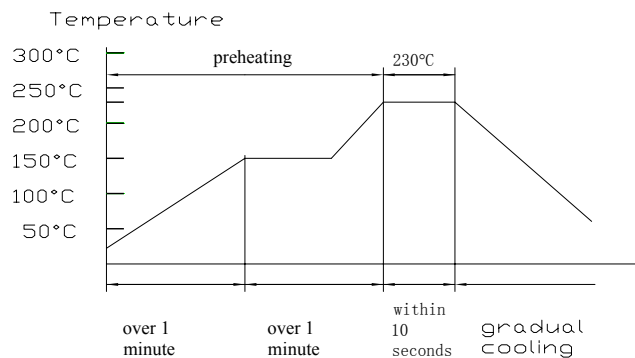

注意 Caution

①. 理想状况的焊锡高度为电容器厚度的 1/2 ~1/3，如下图所示：

①.The ideal condition is to have solder mass (fillet) controlled to 1/2 to 1/3 of the thickness of the capacitor, as shown below:

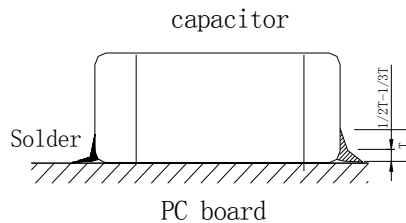

②. 过长的焊接时间会影响端头的可焊性，焊接时间尽可能保持与推荐时间一致。

②. Because excessive dwell times can detrimentally affect solderability, soldering duration should be kept as close to recommended times as possible.

波峰焊 Wave solder profile

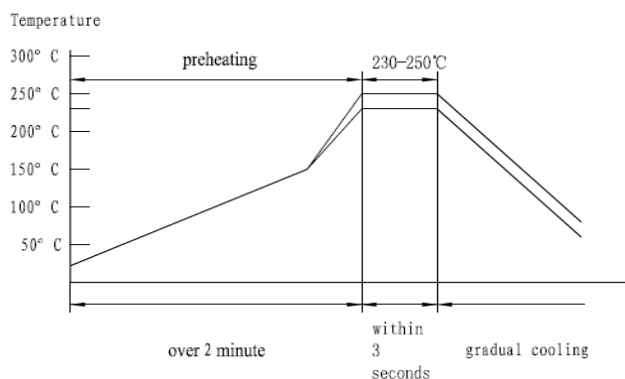



产品标准书	编号 Document No.
SPECIFICATION FOR APPROVAL	DRAAW108F/0-2014

注意 Caution

- ①. 确保电容器充分预热。
- ②. 产品预热和焊接温度差不超过 100~130℃。
- ③. 焊接后尽可能慢速冷却。
- ①. Make sure the capacitors are preheated sufficiently.
- ②. The temperature difference between the capacitor and melted solder should not be greater than 100 to 130℃.
- ③. Cooling after soldering should be gradual as possible.

手工焊接 Hand soldering

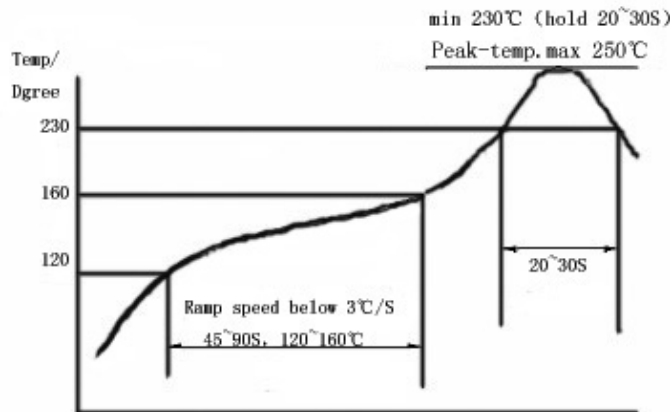

注意 Caution

- ①. 用尖端最大直径 1.0mm 功率 20W 的焊接烙铁。
- ②. 焊接烙铁不要直接接触产品。
- ①. Use a 20w soldering iron with a maximum tip diameter of 1.0mm.
- ②. The soldering iron should not directly touch the capacitor.

8.3.3 无铅焊接曲线 Recommended Pb-Free soldering profile

回流焊接 Reflow soldering

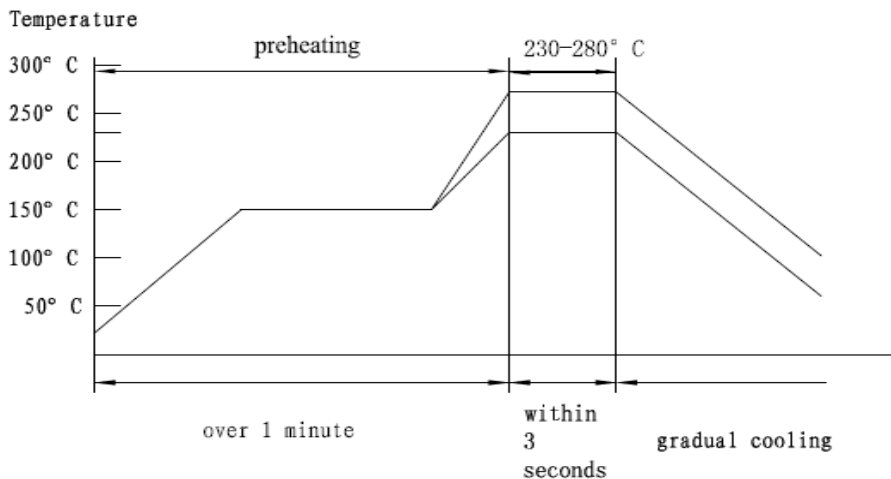



产品标准书	编号 Document No.
SPECIFICATION FOR APPROVAL	DRAAW108F/0-2014

波峰焊接 Wave solder profile

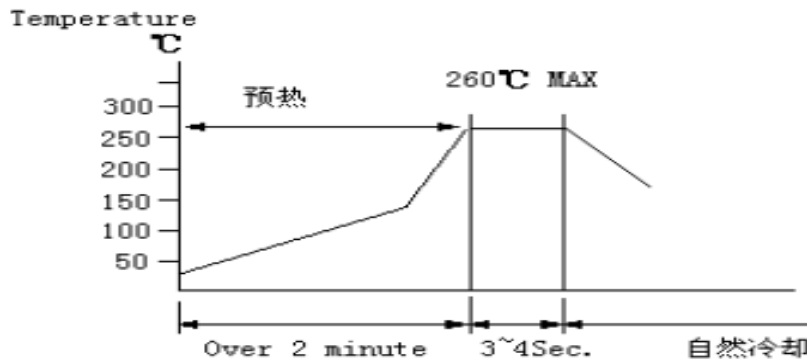

8.4 分拨电路板 Handling

Breakaway PC boards (splitting along perforations)

- (1). 在电容器或其它贴装后，必须注意因电路板弯曲或变形带来的应力。
- (2). 分拨电路板时必须使用专用的夹具，不可以用手拨断。

- (1). When splitting the PC board after mounting capacitors and other components, care is required so as not to give any stresses of deflection or twisting to the board.
- (2). Board separation should not be done manually, but by using the appropriate devices.

8.5 保存 Storage

(1). 在下列环境中保存产品：温度 5~40°C；湿度 ≤70% RH

(2). 产品自生产之日保存期为一年，产品使用之前请勿拆开编带。

(3). 编带拆开后，产品应在三个月内使用。

(4). 高介电常数电容器的容值随时间会逐渐减小，所以在电路设计时应充分考虑这一现象。容值减小的电容器在 150°C 热处理 1 小时后容值会恢复到初试值。

(1). Keep the storage environment conditions as following:

Temperature: 5~40°C

Humidity: ≤70% RH

(2). Don't open the tape until the parts are to be used, and store them within one year since the date printed on the reel.

(3). Use the chips within 3 months after the tape is opened.

(4). The capacitance value of high dielectric constant capacitors will gradually decrease with the passage of time, so this should be taken into consideration in the circuit design. If such a capacitance reduction occurs, a heat treatment of 150°C for 1 hour will return the capacitance to its initial level.



CCTC
三环集团

潮州三环（集团）股份有限公司

Chaozhou Three-Circle (Group) Co., Ltd.

地址：广东省潮州市凤塘三环工业城 邮编(Post Code)：515646

ADD：San Huan Industrial District ,Feng Tang Chao Zhou, GuangDong, China

产品标准书	编号 Document No.
SPECIFICATION FOR APPROVAL	DRAAW108F/0-2014

8.6 MLCC 产品的电压及温度使用注意事项

8.6.1 工作温度方面

有必要选择高于使用温度以上的额定温度产品。另外，还需考虑机器内的温度分布以及季节性的温度变化。

当超过额定工作温度时会产生问题如在高于上限工作温度的条件下使用电容器，电容器会产生绝缘电阻低下、电流突然急剧增大或短路的问题。

电容器中使用了介电常数随温度变化的陶瓷介质，所以在使用温度范围较宽下，其静电容量可能会发生很大的变化。所以为了确保静电容量，我们推荐以下的方法：

(1) 在实际使用中控制使用温度范围，以此来抑制由于温度带来的静电容量变化率。

(2) 所谓的温度特性，即使周围温度在额定温度以下，随着温度的变化静电容量也可能产生变化。因此在时间恒定的回路等实效静电容量范围较小的回路上使用时，除了以上的内容，也请在考虑直流电压特性以及静电容量的放置特性之后选择电容器

8.6.1 额定电压方面

(1) 对电容器施加的电压，请控制在规格书中规定的额定电压以下。（推荐使用在额定电压的 70%以下使用）

如果是直流电压和交流电压组合起来使用的情况，请保持峰值电压之和（Zero-to-peak 电压）在额定电压以下。用于交流或脉冲电压时，峰值电压之和（Peak-to-peak 电压）应低于额定电压。

如果在超过目录或规格书所规定的额定电压下使用电容器可能产生由于陶瓷介质的绝缘破坏导致的电气短路。另外，根据施加电压以及周围温度的不同，发生不良的时间也不同。

(2) 即使在额定电压以下使用，但如果在高速脉冲电压或高频交流电压下使用，也有可能导致电容器可靠性下降。

8.7 产品在较高的温度下使用，寿命会大幅降低，请客户在使用前做好相关的寿命试验。